

# Beechcraft®

## Debonair® 35-C33

*and*

## Bonanza® E33 F33

### Pilot's Operating Handbook *and* FAA Approved Airplane Flight Manual

FAA Approved in Utility Category based on CAR 3. This document must be carried in the airplane at all times and be kept within reach of the pilot during all flight operations.

This handbook includes the material required to be furnished to the pilot by CAR 3.

Airplane Serial Number: \_\_\_\_\_

Airplane Registration Number: \_\_\_\_\_

FAA Approved: \_\_\_\_\_

  
A. C. Jackson  
Beech Aircraft Corporation  
DOA CE-2

This handbook supersedes all BEECH published owner's manuals, flight manuals, and check lists issued for this airplane with the exception of FAA Approved Airplane Flight Manual Supplements.

COPYRIGHT © BEECH 1996

P/N 33-590002-9B  
Reissued: August, 1982

P/N 33-590002-9B3  
Revised: January, 1996

Published By  
**RAYTHEON AIRCRAFT COMPANY**  
P.O. Box 85  
Wichita, Kansas 67201  
U.S.A.

**NOTE**

Where Beech Aircraft Corporation or Beechcraft is referred to in this publication, it will be taken to read Raytheon Aircraft Company.

**Raytheon** Aircraft

**Beech**  
**Hawker**



Member of GAMA

General Aviation  
Manufacturers Association

# Raytheon Aircraft

35-C33, E33 & F33

Log of Temporary Changes

to the

Pilot's Operating Handbook

and

FAA Approved Airplane Flight Manual

P/N 33-590002-9B

*Changes to this Pilot's Operating Handbook and FAA Approved Airplane Flight Manual must be in the airplane for all flight operations.*

Part Number	Subject	Date
33-590002-9BTC1	Fuel Selector Placard Installation	8/26/97

**Note:** This page should be filed in the front of the *Pilot's Operating Handbook and FAA Approved Airplane Flight Manual* immediately following the *Title* page. This page replaces any *Log of Temporary Changes* page dated prior to the date in the lower right corner of this page.

**DEBONAIR 35-C33 AND  
BONANZA E33/F33  
PILOT'S OPERATING HANDBOOK  
AND  
FAA APPROVED AIRPLANE FLIGHT MANUAL  
P/N 33-590002-9B**

*"B3" Revision . . . . . January, 1996*

**LOG OF REVISIONS**

<b>Page</b>	<b>Description</b>
Title Page	Updated
Page A (B3)	New
10-1 thru 10-48	Revised Section X, Safety Information (May, 1994)
	<b>B3</b>

**DEBONAIR 35-C33 AND  
BONANZA E33/F33  
PILOT'S OPERATING HANDBOOK  
AND**

**FAA APPROVED AIRPLANE FLIGHT MANUAL**

B2 Revision . . . . . October, 1990

**LOG OF REVISIONS**

Page	Description
Title Page	Updated
Page A (B2)	New
10-1 thru 10-48	Revised Section X, Safety Information (October, 1990)
	B2

**DEBONAIR C33  
BONANZA E33 and F33**

**Pilot's Operating Handbook  
and FAA Approved  
Airplane Flight Manual**

B1 ..... MARCH 1983

**LOG OF REVISIONS**

<b>PAGES</b>	<b>DESCRIPTION</b>
Title Page A Page (B1) a & b Page 2-17 3-2 3-12, 3-13  4-11 7-1, 7-2 7-20  8-29, 8-30, 8-30A, 8-30B & 8-31	Update Title Page Update Add "Warning" Add "Emergency Exit" placard Update Table of Contents Revise "Emergency Exits" and Shift Material Revise "Before Takeoff" Update Table of Contents Revise "Openable Cabin Windows" and add "Emergency Exits" Revise "Cleaning - Exterior Painted Surfaces"

**B1**



**Debonair C33  
Bonanza E33 and F33**

## **INTRODUCTION**

This Pilot's Operating Handbook and FAA Approved Airplane Flight Manual is in the format and contains data recommended in the GAMA (General Aviation Manufacturers Association) Handbook Specification Number 1. Use of this specification by all manufacturers will provide the pilot the same type data in the same place in all of the handbooks.

In recent years, BEECHCRAFT handbooks contained most of the data now provided, however, the new handbooks contain more detailed data and some entirely new data.

For example, attention is called to Section X SAFETY INFORMATION. BEECHCRAFT feels it is highly important to have SAFETY INFORMATION in a condensed form in the hands of the pilots. The SAFETY INFORMATION should be read and studied. Periodic review will serve as a reminder of good piloting techniques.

### **WARNING**

Use only genuine BEECHCRAFT or BEECHCRAFT approved parts obtained from BEECHCRAFT approved sources, in connection with the maintenance and repair of Beech airplanes.

Genuine BEECHCRAFT parts are produced and inspected under rigorous procedures to ensure airworthiness and suitability for use in Beech airplane applications. Parts purchased from sources other than BEECHCRAFT, even though outwardly identical in appearance, may not have had the required tests and inspections performed, may be different in fabrication techniques and materials, and may be dangerous when installed in an airplane.

**DEBONAIR C33  
BONANZA E33 and F33**

Salvaged airplane parts, reworked parts obtained from non-BEEHCRAFT approved sources, or parts, components, or structural assemblies, the service history of which is unknown or cannot be authenticated, may have been subjected to unacceptable stresses or temperatures or have other hidden damage, not discernible through routine visual or usual nondestructive testing techniques. This may render the part, component or structural assembly, even though originally manufactured by BEEHCRAFT, unsuitable and unsafe for airplane use.

BEEHCRAFT expressly disclaims any responsibility for malfunctions, failures, damage or injury caused by use of non-BEEHCRAFT approved parts.

## **TABLE OF CONTENTS**

SECTION 1	.....	General
SECTION 2	.....	Limitations
SECTION 3	.....	Emergency Procedures
SECTION 4	.....	Normal Procedures
SECTION 5	.....	Performance
SECTION 6	.....	Weight and Balance/Equipment List
SECTION 7	.....	Systems Description
SECTION 8	.....	Handling, Servicing and Maintenance
SECTION 9	.....	Supplements
SECTION 10	.....	Safety Information

**BEECHCRAFT**  
**Debonair C33**  
**Bonanza E33 and F33**

# **SECTION I**

## **GENERAL**

### **TABLE OF CONTENTS**

<i>SUBJECT</i>	<i>PAGE</i>
Important Notice .....	1-3
Use of the Handbook .....	1-4
Revising the Handbook .....	1-7
Airplane Flight Manual Supplements	
Revision Record .....	1-8
Vendor-Issued STC Supplements .....	1-8
Airplane Three View .....	1-9
Ground Turning Clearance .....	1-10
Descriptive Data .....	1-11
Engine .....	1-11
Propeller .....	1-11
Fuel .....	1-11
Oil Capacity .....	1-12
Weights .....	1-12
Cabin And Entry Dimensions .....	1-12
Baggage Space and Entry Dimensions .....	1-12
Specific Loadings .....	1-12
General Airspeed Terminology and Symbols .....	1-13
Meteorological Terminology .....	1-15
Power Terminology .....	1-16
Engine Controls and Instruments .....	1-16
Airplane Performance and Flight	
Planning Terminology .....	1-17
Weight and Balance Terminology .....	1-18
<b>August 1982</b>	<b>1-1</b>

**INTENTIONALLY LEFT BLANK**

**THANK YOU . . .** for displaying confidence in us by selecting a BEECHCRAFT airplane. Our design engineers, assemblers and inspectors have utilized their skills and years of experience to ensure that the BEECHCRAFT Debonair/Bonanza meets the high standards of quality and performance for which BEECHCRAFT airplanes have become famous throughout the world.

### **IMPORTANT NOTICE**

This handbook must be read carefully by the owner and operator in order to become familiar with the operation of the BEECHCRAFT Debonair/Bonanza. The handbook presents suggestions and recommendations to help obtain safe and maximum performance without sacrificing economy. The BEECHCRAFT Debonair/Bonanza must be operated according to the Pilot's Operating Handbook and FAA Approved Airplane Flight Manual, and/or placards located in the airplane.

As a further reminder, the owner and operator of this airplane should also be familiar with the Federal Aviation Regulations applicable to the operation and maintenance of the airplane and FAR Part 91 General Operating and Flight Rules. Further, the airplane must be operated and maintained in accordance with FAA Airworthiness Directives which may be issued against it.

The Federal Aviation Regulations place the responsibility for the maintenance of this airplane on the owner and the operator who must ensure that all maintenance is done by qualified mechanics in conformity with all airworthiness requirements established for this airplane.

All limits, procedures, safety practices, time limits, servicing, and maintenance requirements contained in this handbook are considered mandatory for the continued

airworthiness of this airplane, in a condition equal to that of its original manufacture.

Authorized BEEHCRAFT Aero or Aviation Centers or International Distributors or Dealers can provide recommended modification, service, and operating procedures issued by both FAA and Beech Aircraft Corporation, which are designed to get maximum utility and safety from this airplane.

### **USE OF THE HANDBOOK**

The Pilot's Operating Handbook is designed to maintain documents necessary for the safe and efficient operation of the BEEHCRAFT Debonair/Bonanza. The handbook has been prepared in loose leaf form for ease in maintenance and in a convenient size for storage. The handbook has been arranged with quick reference tabs imprinted with the title of each section and contains ten basic divisions:

Section 1 General

Section 2 Limitations

Section 3 Emergency Procedures

Section 4 Normal Procedures

Section 5 Performance

Section 6 Weight and Balance/Equipment List

Section 7 Systems Description

Section 8 Handling, Servicing and Maintenance

Section 9 Supplements

Section 10 Safety Information

**NOTE**

Except as noted, all airspeeds quoted in this handbook are Indicated Airspeeds (IAS) and assume zero instrument error.

In an effort to provide as complete coverage as possible, applicable to any configuration of the airplane, some optional equipment has been included in the scope of the handbook. However, due to the variety of airplane appointments and arrangements available, optional equipment described and depicted herein may not be designated as such in every case.

The following information may be provided to the holder of this manual automatically:

1. Original issues and revisions of Class I and Class II Service Instructions
2. Original issues and revisions of FAA Approved Airplane Flight Manual Supplements
3. Reissues and revisions of FAA Approved Airplane Flight Manuals, Flight Handbooks, Owner's Manuals, Pilot's Operating Manuals, and Pilot's Operating Handbooks

This service is free and will be provided only to holders of this handbook who are listed on the FAA Aircraft Registration Branch List or the BEECHCRAFT International Owners Notification Service List, and then only if listed by

airplane serial number for the model for which this handbook is applicable. For detailed information on how to obtain "Revision Service" applicable to this handbook or other BEEHCRAFT Service Publications, consult a BEEHCRAFT Aero or Aviation Center, International Distributor or Dealer, or refer to the latest revision of BEEHCRAFT Service Instructions No. 0250-010.

**BEECH AIRCRAFT CORPORATION EXPRESSLY RESERVES THE RIGHT TO SUPERSEDE, CANCEL, AND/OR DECLARE OBSOLETE, WITHOUT PRIOR NOTICE, ANY PART, PART NUMBER, KIT OR PUBLICATION REFERENCED IN THIS HANDBOOK.**

The owner/operator should always refer to all supplements, whether STC Supplements or Beech Supplements, for possible placards, limitations, normal, emergency and other operational procedures for proper operation of the airplane with optional equipment installed.

## **REVISING THE HANDBOOK**

Immediately following the title page is the "Log of Revisions" page(s). The Log of Revisions pages are used for maintaining a listing of all effective pages in the handbook (except the SUPPLEMENTS section), and as a record of revisions to these pages. In the lower right corner of the outlined portion of the Log of Revisions is a box containing a capital letter which denotes the issue or reissue of the handbook. This letter may be suffixed by a number which indicates the numerical revision. When a revision to any information in the handbook is made, a new Log of Revisions will be issued. All Logs of Revisions must be retained in the handbook to provide a current record of material status until a reissue is made.

### **WARNING**

When this handbook is used for airplane operational purposes it is the pilot's responsibility to maintain it in current status.

## **AIRPLANE FLIGHT MANUAL SUPPLEMENTS REVISION RECORD**

Section IX contains the FAA Approved Airplane Flight Manual Supplements headed by a Log of Supplements page. On the "Log" page is a listing of the FAA Approved Supplemental Equipment available for installation on the airplane. When new supplements are received or existing supplements are revised, a new "Log" page will replace the previous one, since it contains a listing of all previous approvals, plus the new approval. The supplemental material will be added to the grouping in accordance with the descriptive listing.

### **NOTE**

Upon receipt of a new or revised supplement, compare the "Log" page just received with the existing "Log" page in the manual. Retain the "Log" page with the latest date on the bottom of the page and discard the other log.

## **VENDOR-ISSUED STC SUPPLEMENTS**

When a new airplane is delivered from the factory, the handbook delivered with it contains either an STC (Supplemental Type Certificate) Supplement or a Beech Flight Manual Supplement for every installed item requiring a supplement. If a new handbook for operation of the airplane is obtained at a later date, it is the responsibility of the owner/operator to ensure that all required STC Supplements (as well as weight and balance and other pertinent data) are transferred into the new handbook.

**BEECHCRAFT  
Debonair C33  
Bonanza E33 and F33**

**Section I  
General**

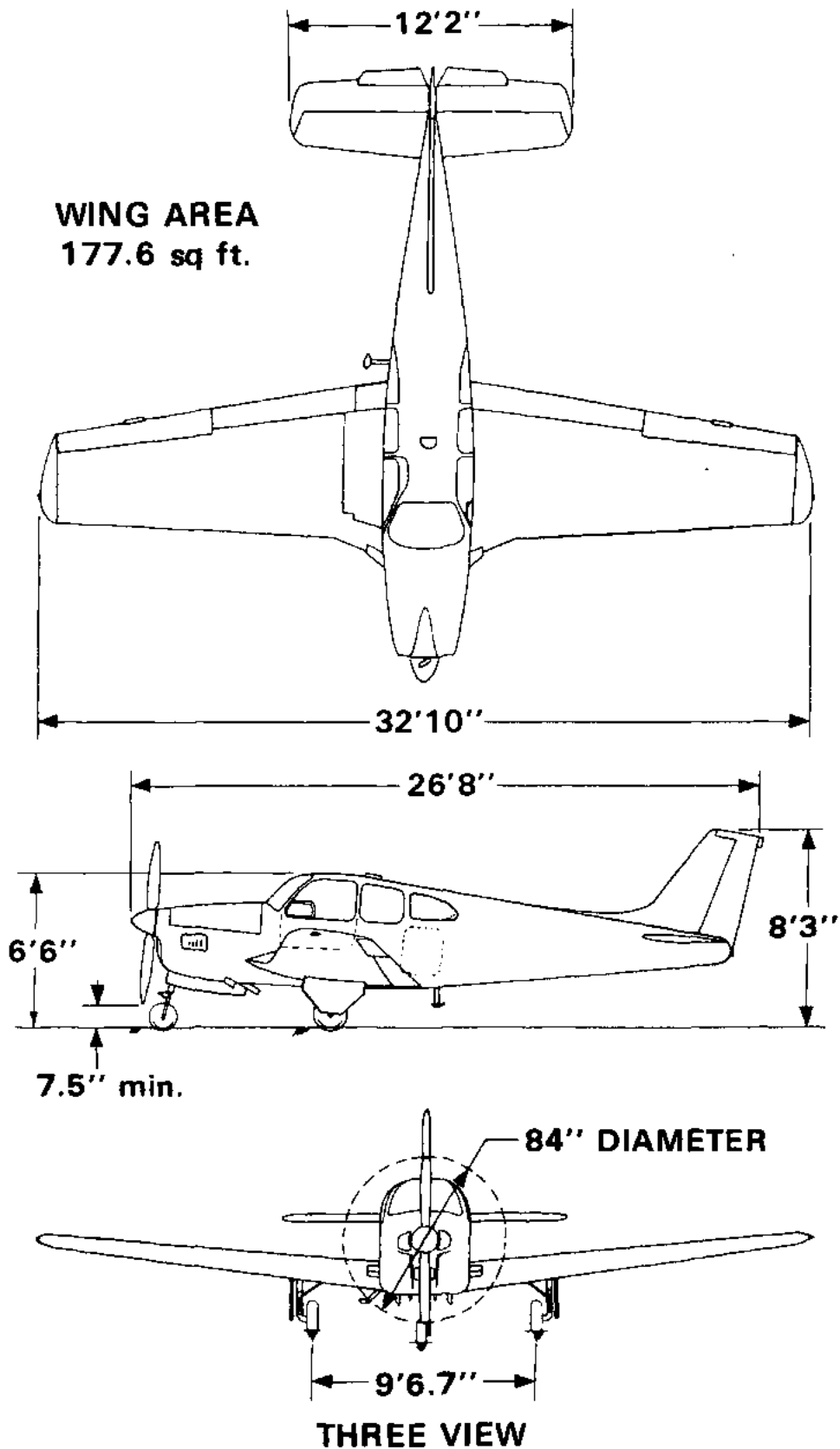

### GROUND TURNING CLEARANCE

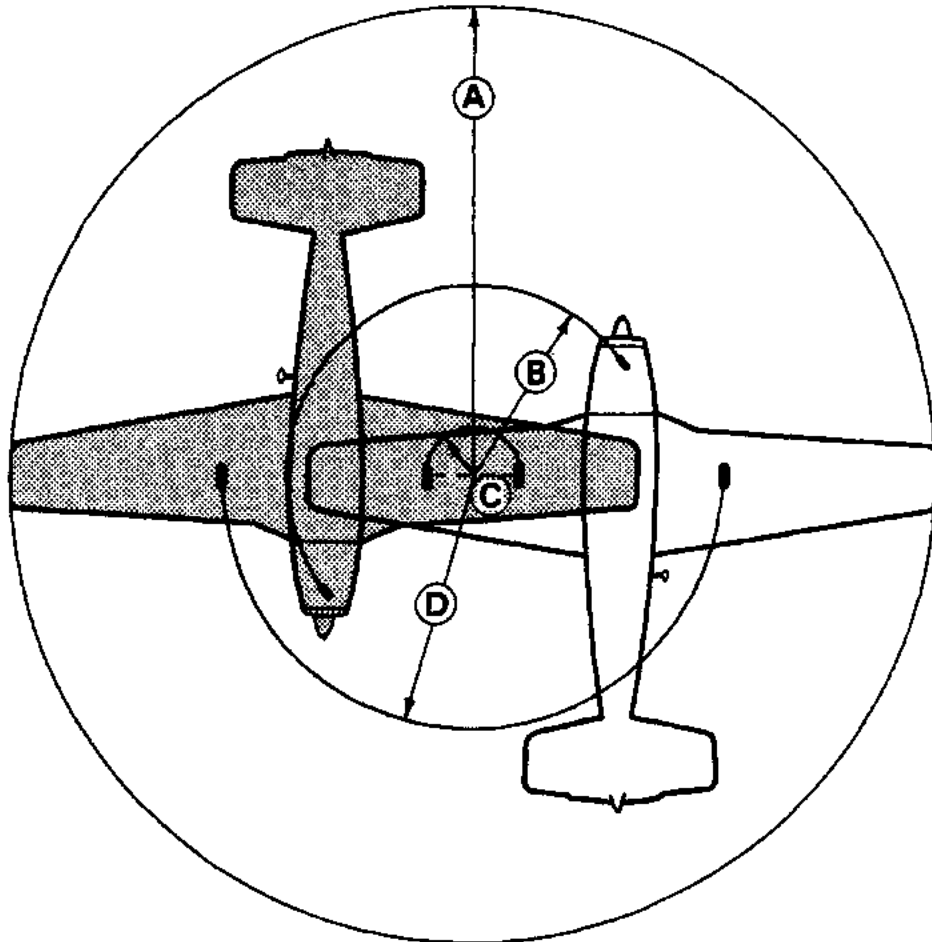

- Ⓐ Radius for Wing Tip ..... 26 ft. 4 in.
- Ⓑ Radius for Nose Wheel ..... 12 ft. 2 in.
- Ⓒ Radius for Inside Gear ..... 5 ft. 1 in.
- Ⓓ Radius for Outside Gear ..... 14 ft. 8 in.

TURNING RADII ARE CALCULATED USING FULL STEERING, ONE BRAKE AND PARTIAL POWER.

**DESCRIPTIVE DATA**

**ENGINE**

The BEECHCRAFT C33, E33, and F33 airplanes are all powered by a Continental IO-470-K, six-cylinder, wet sump, fuel-injection engine rated at 225 hp at 2600 rpm for take-off and maximum continuous operation.

**PROPELLER**

McCauley constant speed, two blade, 84 inch diameter propeller using a McCauley 2A36C23 hub with 84B-0 blades.

or

(Optional on C33 only)

Hartzell constant speed, three blade, 80 inch diameter propeller using a Hartzell PHC-A3VF-4 hub with V8433-4R blades.

**NOTE**

Other propellers are approved but not installed as original equipment. These are listed in the FAA Aircraft Specification 3A15 or approved by Supplemental Type Certificate.

**FUEL**

Aviation Gasoline 80/87 (red) minimum grade or alternate grades 100LL (blue) or 100 (green). See Engine Manufacturer's Bulletin.

**STANDARD SYSTEM**

Total Capacity .....	50 gal.
Total Usable .....	44 gal.

**OPTIONAL SYSTEM**

Total Capacity .....	80 gal.
Total Usable .....	74 gal.

**OIL CAPACITY**

The oil capacity is 10 quarts.

**WEIGHTS**

Maximum Ramp Weight .....	3060 lbs
Maximum Take-Off Weight .....	3050 lbs
Maximum Landing Weight .....	3050 lbs
Maximum Zero Fuel Weight .....	No Structural Limit
Maximum Weight in Baggage Compartment .....	270 lbs.

**CABIN AND ENTRY DIMENSIONS**

Length .....	6 ft 11 in.
Height .....	4 ft 2 in.
Width .....	3 ft 6 in.
Cabin Door .....	37 in. wide by 36 in. high

**BAGGAGE SPACE AND ENTRY DIMENSIONS**

Compartment Volume .....	16.5 cu ft
With Utility Shelf .....	22.4 cu ft
Door Width (Minimum) .....	18.5 in.
Door Height (Minimum) .....	22.5 in.

**SPECIFIC LOADINGS (Maximum Take-Off Weight)**

Wing Loading .....	17.2 lbs/sq ft
Power Loading .....	13.5 lbs/hp

**GENERAL AIRSPEED TERMINOLOGY  
AND SYMBOLS**

**CAS** Calibrated Airspeed is the indicated speed of an airplane, corrected for position and instrument error. Calibrated airspeed is equal to true airspeed in standard atmosphere at sea level.

**GS** Ground Speed is the speed of an airplane relative to the ground.

**IAS** Indicated Airspeed is the speed of an airplane as shown on the airspeed indicator when corrected for instrument error. IAS values published in this handbook assume zero instrument error.

**KCAS** Calibrated Airspeed expressed in "knots".

**KIAS** Indicated Airspeed expressed in "knots".

**TAS** True Airspeed is the airspeed of an airplane relative to undisturbed air which is the CAS corrected for altitude, temperature, and compressibility.

**V<sub>A</sub>** Maneuvering Speed is the maximum speed at which application of full available aerodynamic control will not overstress the airplane.

**V<sub>FE</sub>** Maximum Flap Extended Speed is the highest speed permissible with wing flaps in a prescribed extended position.

- $V_{LE}$  Maximum Landing Gear Extended Speed is the maximum speed at which an airplane can be safely flown with the landing gear extended.
- $V_{LO}$  Maximum Landing Gear Operating Speed is the maximum speed at which the landing gear can be safely extended or retracted.
- $V_{NE}$  Never Exceed Speed is the speed limit that may not be exceeded at any time.
- $V_{NO}$  or  $V_C$  Maximum Structural Cruising Speed is the speed that should not be exceeded except in smooth air and then only with caution.
- $V_S$  Stalling Speed or the minimum steady flight speed at which the airplane is controllable.
- $V_{SO}$  Stalling Speed or the minimum steady flight speed at which the airplane is controllable in the landing configuration.
- $V_X$  Best Angle-of-Climb Speed is the airspeed which delivers the greatest gain of altitude in the shortest possible horizontal distance.
- $V_Y$  Best Rate-of-Climb Speed is the airspeed which delivers the greatest gain in altitude in the shortest possible time.

## **METEOROLOGICAL TERMINOLOGY**

<b>ISA</b>	<p>International Standard Atmosphere in which</p> <ol style="list-style-type: none"><li>(1) The air is a dry perfect gas;</li><li>(2) The temperature at sea level is 15° Celsius (59° Fahrenheit);</li><li>(3) The pressure at sea level is 29.92 in Hg. (1013.2 millibars);</li><li>(4) The temperature gradient from sea level to the altitude at which the temperature is -56.5° C (-69.7° F) is -0.00198° C (-0.003566° F) per foot and zero above that altitude.</li></ol>
<b>OAT</b>	<p>Outside Air Temperature is the free air static temperature, obtained either from inflight temperature indications adjusted for instrument error and compressibility effects, or ground meteorological sources.</p>
<b>Indicated Pressure Altitude</b>	<p>The number actually read from an altimeter when the barometric sub-scale has been set to 29.92 in Hg. (1013.2 millibars).</p>
<b>Pressure Altitude</b>	<p>Altitude measured from standard sea-level pressure (29.92 in. Hg) by a pressure or barometric altimeter. It is the indicated pressure altitude corrected for position and instrument error. In this Handbook, altimeter instrument errors are assumed to be zero. Position errors may be obtained from the Altimeter Correction Graph.</p>

Station Pressure	Actual atmospheric pressure at field elevation.
Wind	The wind velocities recorded as variables on the charts of this handbook are to be understood as the headwind or tailwind components of the reported winds.

### **POWER TERMINOLOGY**

Take off and Maximum Continuous	Highest power rating not limited by time.
Cruise Climb	Power recommended for cruise climb.

### **ENGINE CONTROLS AND INSTRUMENTS**

Throttle Control	Used to control power by introducing fuel-air mixture into the intake passages of the engine. Settings are reflected by readings on the manifold pressure gage.
Propeller Control	This control requests the propeller governor to maintain engine/propeller rpm at a selected value by controlling propeller blade angle.
Mixture Control	This control is used to set fuel flow in all modes of operation and cuts off fuel completely for engine shut down.

EGT (Exhaust Gas Temperature Indicator)	This indicator is used to identify the lean and best power fuel flow for various power settings.
Tachometer	Indicates the rpm of the engine/propeller.
Propeller Governor	Regulates the rpm of the engine/propeller by increasing or decreasing the propeller pitch through a pitch change mechanism in the propeller hub.

#### **AIRPLANE PERFORMANCE AND FLIGHT PLANNING TERMINOLOGY**

Climb Gradient	The ratio of the change in height during a portion of a climb, to the horizontal distance traversed in the same time interval.
Demonstrated Crosswind Velocity	The demonstrated crosswind velocity is the velocity of the crosswind component for which adequate control of the airplane during takeoff and landing was actually demonstrated during certification tests. The value shown is considered to be limiting.
MEA	Minimum enroute IFR altitude.
Route Segment	A part of a route. Each end of that part is identified by: (1) a geographical location; or (2) a point at which a definite radio fix can be established.

**Section I  
General**

**BEECHCRAFT  
Debonair C33  
Bonanza E33 and F33**

GPH U.S. Gallons per hour.

PPH Pounds per hour.

**WEIGHT AND BALANCE TERMINOLOGY**

Reference Datum	An imaginary vertical plane from which all horizontal distances are measured for balance purposes.
Station	A location along the airplane fuselage usually given in terms of distance from the reference datum.
Arm	The horizontal distance from the reference datum to the center of gravity (C.G.) of an item.
Moment	The product of the weight of an item multiplied by its arm. (Moment divided by a constant is used to simplify balance calculations by reducing the number of digits.)
Airplane Center of Gravity (C.G.)	The point at which an airplane would balance if suspended. Its distance from the reference datum is found by dividing the total moment by the total weight of the airplane.
C.G. Arm	The arm obtained by adding the airplane's individual moments and dividing the sum by the total weight.

C.G. Limits	The extreme center of gravity locations within which the airplane must be operated at a given weight.
Usable Fuel	Fuel available for flight planning.
Unusable Fuel	Fuel remaining after a runout test has been completed in accordance with governmental regulations.
Standard Empty Weight	Weight of a standard airplane including unusable fuel, full operating fluids and full oil.
Basic Empty Weight	Standard empty weight plus optional equipment.
Payload	Weight of occupants, cargo and baggage.
Useful Load	Difference between take-off weight, or ramp weight if applicable, and basic empty weight.
Maximum Ramp Weight	Maximum weight approved for ground maneuvering. (It includes weight of start, taxi, and run-up fuel).
Maximum Take-off Weight	Maximum weight approved for the start of the take-off run.
Maximum Landing Weight	Maximum weight approved for the landing touchdown.

**Section I  
General**

**BEECHCRAFT  
Debonair C33  
Bonanza E33 and F33**

**Zero Fuel  
Weight**

Weight exclusive of usable fuel.

**Tare**

The weight of chocks, blocks, stands, etc., used on the scales when weighing an airplane.

**Leveling  
Points**

Those points which are used during the weighing process to level the airplane.

**Jack  
Points**

Points on the airplane identified by the manufacturer as suitable for supporting the airplane for weighing or other purposes.

# **SECTION II**

## **LIMITATIONS**

### **TABLE OF CONTENTS**

<i>SUBJECT</i>	<i>PAGE</i>
Airspeed Limitations .....	2-3
Airspeed Indicator Markings .....	2-4
Power Plant Limitations .....	2-5
Engine .....	2-5
Operating Limitations .....	2-5
Fuel Grades .....	2-5
Oil Specifications .....	2-5
Propeller Specifications .....	2-6
Power Plant Instrument Markings .....	2-7
Miscellaneous Instrument Markings .....	2-8
Weight Limits .....	2-8
Center of Gravity Limits .....	2-9
Maneuver Limits .....	2-9
Approved Maneuvers .....	2-9
Flight Load Factors .....	2-10
Minimum Flight Crew .....	2-10
Kinds of Operation Limits .....	2-10
Fuel .....	2-11
Seating .....	2-11
Placards .....	2-12
Required Equipment for Various Conditions of Flight .....	2-18

**Section II  
Limitations**

**BEEHCRAFT  
Debonair C33  
Bonanza E33 and F33**

The limitations included in this section have been approved by the Federal Aviation Administration.

**BEECHCRAFT  
Debonair C33  
Bonanza E33 and F33**

**Section II  
Limitations**

The following limitations must be observed in the operation of this airplane.

**AIRSPEED LIMITATIONS**

SPEED	CAS		IAS		REMARKS
	KNOTS	MPH	KNOTS	MPH	
Never Exceed $V_{NE}$	195	225	197	227	Do not exceed this speed in any operation
Maximum Structural Cruising $V_{NO}$ or $V_C$	161	185	162	186	Do not exceed this speed except in smooth air and then only with caution
Maneuvering $V_A$	128	147	128	147	Do not make full or abrupt control movements above this speed
Maximum Flap Extension/Extended $V_{FE}$	① 104	120	104	120	Do not extend flaps or operate with flaps extended above this speed
	② 113	130	116	134	
	③ 122	140	125	144	
Maximum Landing Gear Operating/Extended $V_{LO}$ and $V_{LE}$	④ 143	165	144	166	Do not extend, retract or operate with landing gear extended above this speed except in emergency
	③ 152	175	153	176	

- ① Serials CD-814 thru CD-1118 except CD-982 (See 3A15 Spec.)
- ② Serials CD-1119 thru CD-1199
- ③ Serials CD-1200 thru CD-1254
- ④ Serials CD-814 thru CD-1199

2-4 \*AIRSPEED INDICATOR MARKINGS

MARKING	CAS		IAS		SIGNIFICANCE
	KNOTS	MPH	KNOTS	MPH	
White Arc					Full Flap Operating Range
	53-104	61-120	53-104	61-120	Serials CD-814 thru CD-1118 except CD-982 (See 3A15 Spec.)
	52-113	60-130	53-116	61-134	Serials CD-1119 thru CD-1199
	52-122	60-140	53-125	61-144	Serials CD-1200 thru CD-1254
Green Arc	62-161	71-185	62-162	71-186	Normal Operating Range
Yellow Arc	161-195	185-225	162-197	186-227	Operate with caution only in smooth air
Red Line	195	225	197	227	Maximum speed for ALL operations

\*The Airspeed Indicator is marked in CAS values

**POWER PLANT LIMITATIONS**

**ENGINE**

One Teledyne Continental Motors Corporation model IO-470-K fuel-injected engine.

**OPERATING LIMITATIONS**

Engine Speed .....	2600 rpm
Cylinder Head Temperature .....	460°F/238°C
Oil Temperature .....	225°F/107°C
Oil Pressure	
Minimum .....	30 psi
Maximum .....	80 psi
Fuel Pressure	
Minimum .....	1.5 psi
Maximum .....	17.5 psi
Mixture - Set per leaning instructions on performance charts.	

**FUEL GRADES**

Aviation Gasoline 80/87 (red) minimum grade or alternate grades 100LL (blue) or 100 (green). See Engine Manufacturer's Bulletin.

**OIL SPECIFICATIONS**

Ashless dispersant oils must meet Teledyne Continental Motors Corporation Specification MHS-24B. Refer to APPROVED ENGINE OILS in the Handling, Servicing, and Maintenance section

**Section II  
Limitations**

**BEECHCRAFT  
Debonair C33  
Bonanza E33 and F33**

**PROPELLER SPECIFICATIONS**

McCauley constant speed, two blade propeller

Hub: 2A36C23

Blades: 84B-0

Diameter: Maximum 84 in., Minimum 82 in.

Pitch settings at 30 in. sta.:

Low 12°, High - not under 29.2°

or

(Optional on C33 only)

Hartzell constant speed, three blade propeller

Hub: Hartzell PHC-A3VF-4

Blades: V8433-4R

Diameter: Maximum 80 in., Minimum 78-1/4 in.

Pitch settings at 30 in. sta.:

Low - 10.8° ± 0.2°

High - not under 32°

**NOTE**

Other propellers are approved but not installed as original equipment. These are listed in the FAA Aircraft Specification 3A15 or approved by Supplemental Type Certificate.

**POWER PLANT INSTRUMENT MARKINGS**

**OIL TEMPERATURE**

Caution (Yellow Radial) ..... 100°F/38°C  
Operating Range  
(Green Arc) ..... 100° to 225°F/38° to 107°C  
Maximum (Red Radial) ..... 225°F/107°C

**OIL PRESSURE**

Minimum Pressure (Red Radial) ..... 30 psi  
Operating Range (Green Arc) ..... 30 to 60 psi  
Maximum Pressure (Red Radial) ..... 80 psi

**TACHOMETER**

Operating Range (Green Arc) ... 2000 to 2600 rpm  
Maximum RPM (Red Radial) ..... 2600 rpm

**CYLINDER HEAD TEMPERATURE**

Operating Range  
(Green Arc) ..... 200° to 460°F/93° to 238°C  
Maximum Temperature  
(Red Radial) ..... 460°F/238°C

**MANIFOLD PRESSURE**

Operating Range  
(Green Arc) ..... 15 to 29.6 in. Hg  
Maximum (Red Radial) ..... 29.6 in. Hg

**FUEL FLOW**

Minimum (Red Radial) ..... 1.5 psi  
Operating Range  
(Green Arc) ..... 6.9 to 21.6 gph  
Maximum (Red Radial) ..... 17.5 psi

**MISCELLANEOUS INSTRUMENT MARKINGS**

**INSTRUMENT VACUUM (C33 ONLY)**

Minimum (Red Radial) ..... 3.75 in. Hg  
Operating Range (Green Arc) .. 3.75 to 5.25 in. Hg  
Maximum (Red Radial) ..... 5.25 in. Hg

**INSTRUMENT PRESSURE (E33,F33)**

Minimum (Red Radial) ..... 3.5 in. Hg  
Operating Range (Green Arc) ..... 3.5 to 5.5 in. Hg  
Maximum (Red Radial) ..... 5.5 in. Hg

or

Operating Range (Green Arc) ..... 4.3 to 5.9 in. Hg

**FUEL QUANTITY**

Yellow Band (44-gallon system) ..... E to 1/2 full  
Yellow Band (74-gallon system) ..... E to 3/8 full

**WEIGHT LIMITS**

Maximum Ramp Weight ..... 3060 lbs  
Maximum Take-off  
and Landing Weight ..... 3050 lbs  
Zero Fuel Weight ..... No Structural Limitation  
Maximum Baggage Compartment  
Load ..... 270 lbs.

**CENTER OF GRAVITY LIMITS (Gear Down)**

Forward: 77.0 inches aft of datum to 2700 lbs with straight line variation to 81.5 inches at 3050 lbs.

Aft: 86.7 inches aft of datum at all weights.

**REFERENCE DATUM**

Datum is 83.1 inches forward of center line through forward jack points.

MAC leading edge is 66.7 inches aft of datum.  
MAC length is 65.3 inches.

**MANEUVER LIMITS**

This is a utility category airplane. Spins are prohibited. No acrobatic maneuvers are approved except those listed below. Maximum slip duration is 30 seconds for airplanes with baffled main fuel cells in both wings and 20 seconds for airplanes with unbaffled main fuel cells in either wing.

**APPROVED MANEUVERS (3050 POUNDS)**

MANEUVER	ENTRY SPEED (CAS)
Chandelle .....	128 kts/147 mph
Steep Turn .....	128 kts/147 mph
Lazy Eight .....	128 kts/147 mph
Stall (Except Whip) .....	Use slow deceleration

*Minimum fuel for above maneuvers - 10 gallons each main tank.*

Spins are prohibited.

**Section II  
Limitations**

**BEECHCRAFT  
Debonair C33  
Bonanza E33 and F33**

**FLIGHT LOAD FACTORS (3050 POUNDS)**

**Positive Maneuvering Load Factors**

Flaps Up .....	4.4G
Flaps Down .....	2.0G

**MINIMUM FLIGHT CREW ..... One (1) Pilot**

**KINDS OF OPERATION LIMITS**

This airplane is approved for the following type operations when the required equipment is installed and operational as defined herein:

1. VFR day and night
2. IFR day and night
3. FAR 91 operations when all pertinent limitations and performance considerations are complied with.

**WARNING**

**FLIGHT IN ICING CONDITIONS IS PROHIBITED.**

**NOTE**

Refer to "REQUIRED EQUIPMENT FOR VARIOUS CONDITIONS OF FLIGHT" at the end of this Section.

**FUEL**

**STANDARD SYSTEM**

Total Capacity .....	50 gal.
Total Usable .....	44 gal.

**OPTIONAL SYSTEM**

Total Capacity .....	80 gal.
Total Usable .....	74 gal.

**FUEL MANAGEMENT**

Take off on main tank that is more nearly full.

When operating fuel selector, feel for detent position.

Do not take off when Fuel Quantity Gages indicate in Yellow Band or with less than 13 gallons in each main tank.

Maximum slip duration:

30 seconds for airplanes with baffled main fuel cells in both wings.

20 seconds for airplanes with unbaffled main fuel cells in either wing.

**SEATING**

All seats must be in the upright position for take-off and landing.

**PLACARDS**

*On Fuel Selector Panel:*

**DO NOT TAKE OFF IF FUEL QUANTITY GAGES  
INDICATE IN YELLOW BAND OR WITH LESS  
THAN 13 GALLONS IN EACH MAIN TANK**

*Standard 44 Gallon (Usable) System:*

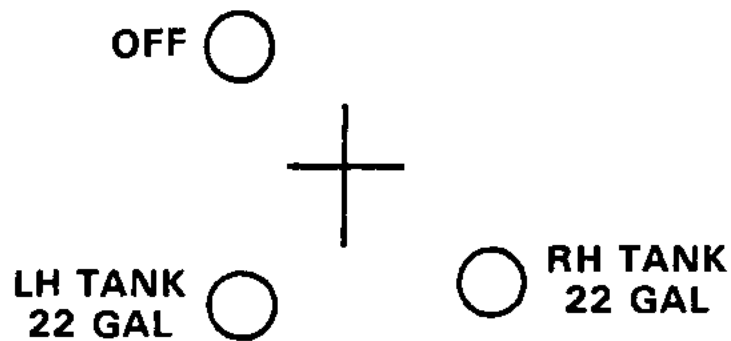

*Optional 74 Gallon (Usable) Fuel System:*

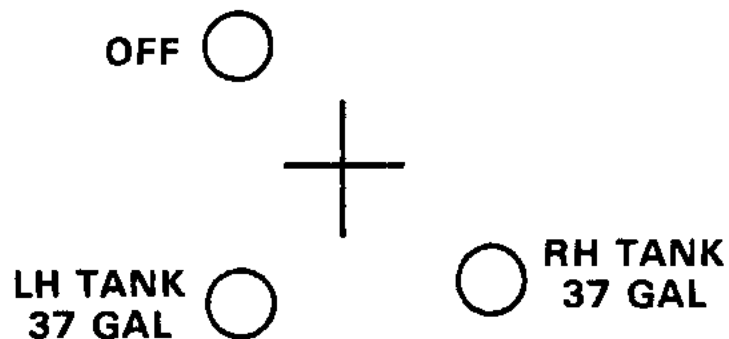

**Temporary Change  
to the  
Pilot's Operating Handbook  
and  
FAA Approved Airplane Flight Manual  
P/N 33-590002-9BTC1**

<b>Publication Affected</b>	35-C33, E33 & F33 Pilot's Operating Handbook and FAA Approved Airplane Flight Manual (P/N 33-590002-9B, Reissued August, 1982 or Subsequent)
<b>Airplane Serial Numbers Affected</b>	CD-814 thru CD-1254, except CD-982
<b>Description of Change</b>	The addition of a placard to the fuel selector to warn of the no-flow condition that exists between the fuel selector detents.
<b>Filing Instructions</b>	Insert this temporary change into the 35-C33, E33 & F33 Pilot's Operating Handbook and FAA Approved Airplane Flight Manual immediately following page 2-12 (Section II, LIMITATIONS) and retain until rescinded or replaced.

**LIMITATIONS**

**PLACARDS**

*Located On The Face Of The Fuel Selector Valve, For Those  
Airplanes In Compliance With S.B. 2670:*

**WARNING - POSITION SELECTOR IN DETENTS ONLY - NO  
FUEL FLOW TO ENGINE BETWEEN DETENTS**

Approved:



---

A.C. Jackson  
Raytheon Aircraft Company  
DOA CE-2

*On Top of Front Spar Carry-Thru Structure Between  
Front Seats:*

**EMERGENCY LANDING GEAR  
INSTRUCTIONS TO EXTEND**

**ENGAGE HANDLE IN REAR OF FRONT SEAT  
AND TURN COUNTERCLOCKWISE AS FAR AS  
POSSIBLE (50 TURNS)**

*Above Landing Gear Mechanical Position Indicator  
When Winter Baffles Are Installed:*

**NOTICE  
REMOVE WINTER  
BAFFLES WHEN  
OAT EXCEEDS 70° F**

*On Left Subpanel: (C33, E33)*

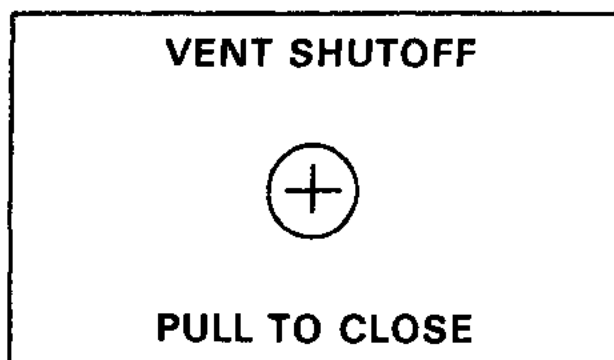

PLACARDS (Cont'd)

*On Left Side Panel Near Firewall Air Controls: (F33)*

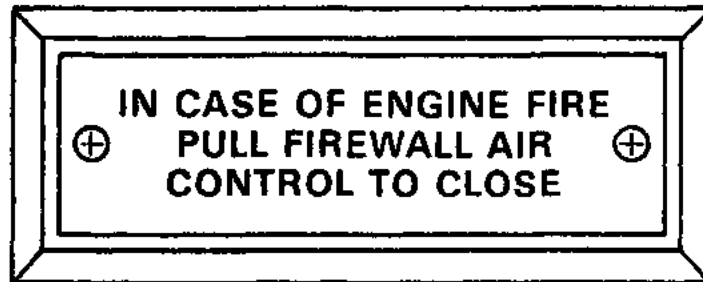

*On Inner Side Of Baggage Compartment Door:*



*On Storm Window: (C33 and E33 only) (CAS)*

**CAUTION**

**DO NOT OPEN ABOVE  
145 MPH (126 KNOTS)**

*In Full View of Pilot: (CAS)*

*Prior to CD-1200*



*CD-1200 and After*

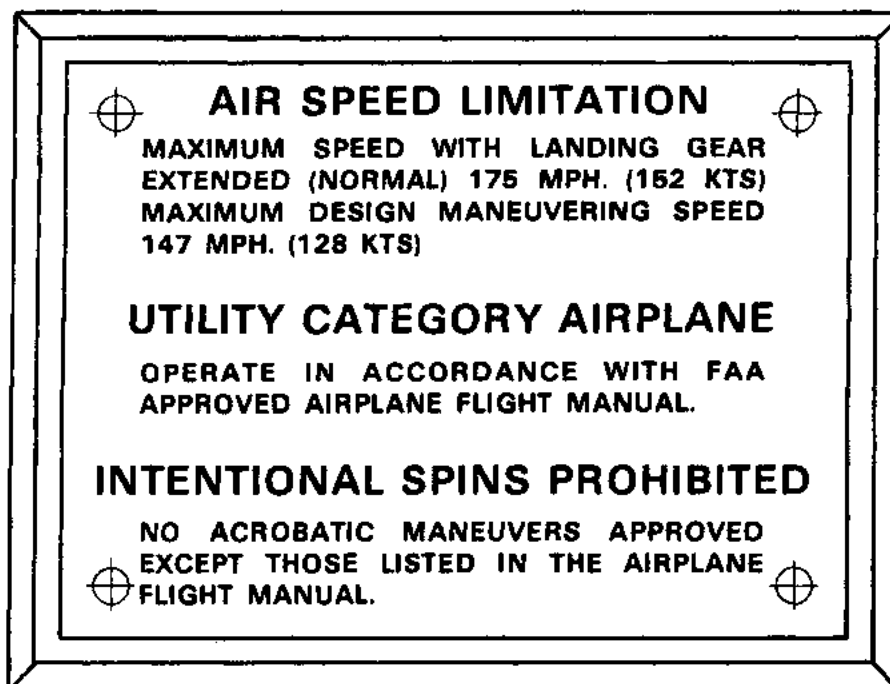

PLACARDS (Cont'd)

*On Control Console:*

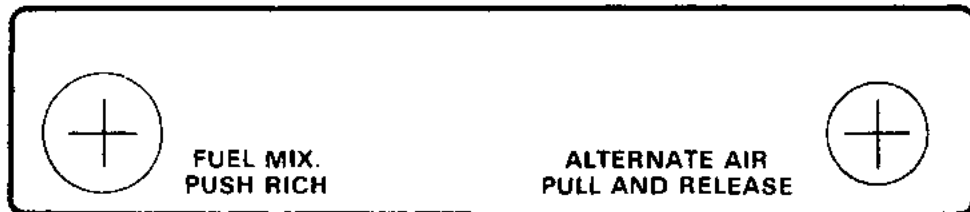
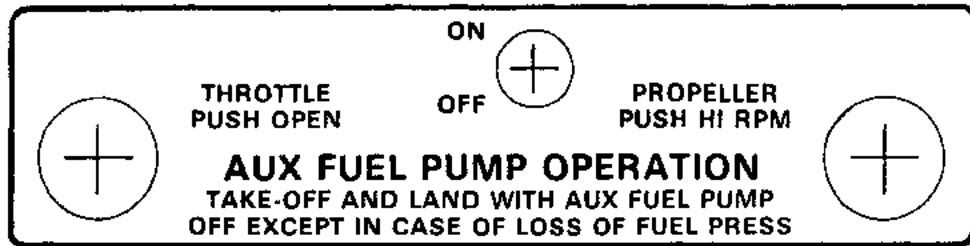

*On Left Side of Control Console Support:*

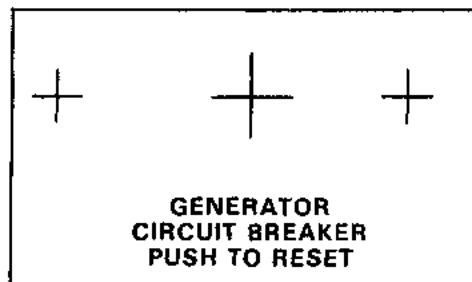

*Above Inside Door Handle:*

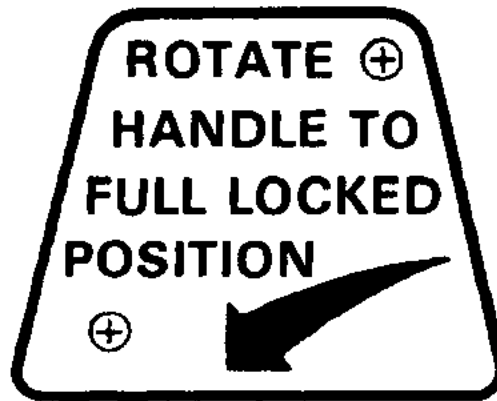

*In full view of the pilot:  
(Unless baffled main fuel cells are installed in both wings.)*

**TURNING TYPE TAKEOFFS, AND  
TAKEOFF IMMEDIATELY FOLLOWING  
FAST TAXI TURN PROHIBITED. AVOID  
PROLONGED SLIPS (20 SECONDS OR  
MORE) WITH FUEL TANKS LESS THAN  
HALF FULL.**

*Below Left and Right Middle Windows after compliance  
with BEECHCRAFT Service Instructions 1241 (E33 and F33  
with Optional Openable Cabin Windows):*

**EMERGENCY EXIT  
LIFT LATCH - PULL PIN  
PUSH WINDOW OUT**

**REQUIRED EQUIPMENT FOR VARIOUS  
CONDITIONS OF FLIGHT**

Part 91 of the Federal Aviation Regulations specifies the minimum numbers and types of airplane instruments and equipment which must be installed and operable for various kinds of flight conditions. This includes VFR day, VFR night, IFR day, and IFR night.

Regulations also require that all airplanes be certificated by the manufacturer for operations under various flight conditions. At certification, all required equipment must be in operating condition and should be maintained to assure continued airworthiness. If deviations from the installed equipment were not permitted, or if the operating rules did not provide for various flight conditions, the airplane could not be flown unless all equipment was operable. With appropriate limitations, the operation of every system or component installed in the airplane is not necessary, when the remaining operative instruments and equipment provide for continued safe operation. Operation in accordance with limitations established to maintain airworthiness, can permit continued or uninterrupted operation of the airplane temporarily.

For the sake of brevity, the Required Equipment Listing does not include obviously required items such as wings, rudders, flaps, engine, landing gear, etc. Also the list does not include items which do not affect the airworthiness of the airplane such as entertainment systems, passenger convenience items, etc. However, it is important to note that **ALL ITEMS WHICH ARE RELATED TO THE AIRWORTHINESS OF THE AIRPLANE AND NOT INCLUDED ON THE LIST ARE AUTOMATICALLY REQUIRED TO BE OPERATIVE.**

To enable the pilot to rapidly determine the FAA equipment requirements necessary for a flight into specific conditions, the following equipment requirements and exceptions are presented. It is the final responsibility of the pilot to determine whether the lack of, or inoperative status of a piece of equipment on his airplane, will limit the conditions under which he may operate the airplane.

**WARNING**

**FLIGHT IN ICING CONDITIONS IS PROHIBITED.**

**LEGEND**

Numbers refer to quantities required to be operative for a specified condition.

(-) Indicates that the item may be inoperative for the specified condition.

(\*) Refer to the REMARKS AND/OR EXCEPTIONS column for explicit information or reference.

**Section II  
Limitations**

**BEECHCRAFT  
Debonair C33  
Bonanza E33 and F33**

SYSTEM and/or COMPONENT	VFR Day				Remarks and/or Exceptions
	VFR Night				
	IFR Day				
	IFR Night				
<b>GENERAL</b>					
Overwater flight	*	*	*	*	-*Per FAR 91
<b>ATA 100 CHAPTER 23 COMMUNICATIONS</b>					
VHF communications system	*	*	*	*	-*Per FAR 91
<b>ATA 100 CHAPTER 24 ELECTRICAL POWER</b>					
Battery	1	1	1	1	
DC alternator/generator	1	1	1	1	

<b>ATA 100 CHAPTER 25 EQUIPMENT AND FURNISHING</b>					
Seat belts	1	1	1	1	- Per Person or Per FAR 91
Shoulder harness	*	*	*	*	-*Pilot and copilot if installed
Emergency locator transmitter	1	1	1	1	- Per FAR 91
<b>ATA 100 CHAPTER 26 FIRE PROTECTION</b>					
Portable fire extinguisher	*	*	*	*	-*Optional

2-22

August 1982

SYSTEM and/or COMPONENT	VFR Day				Remarks and/or Exceptions
	VFR Night				
	IFR Day				
	IFR Night				
<b>ATA 100 CHAPTER 27 FLIGHT CONTROLS</b>					
Elevator trim tab indicator	1	1	1	1	
Flap position indication Lights (C33)	2	2	2	2	
Dial (E33, F33)	1	1	1	1	
Stall warning	1	1	1	1	

<b>ATA 100 CHAPTER 28</b>				
<b>FUEL EQUIPMENT</b>				
Auxiliary fuel pump	1	1	1	1
Engine driven fuel pump	1	1	1	1
Fuel quantity indicator	2	2	2	2
Fuel flow indicator		1	1	1
<b>ATA 100 CHAPTER 30</b>				
<b>ICE AND RAIN PROTECTION</b>				
Emergency static air source	-	-	*	-*Optional Per FAR 135
Pitot heater	*	*	1	-*Optional

2-24

August 1982

SYSTEM and/or COMPONENT	VFR Day				Remarks and/or Exceptions
	VFR Night				
	IFR Day				
	IFR Night				
<b>ATA 100 CHAPTER 32 LANDING GEAR</b>					
Landing gear motor	1	1	1	1	
Landing gear position lights	4	4	4	4	- 2 on the C33 and E33
Landing gear warning horn	1	1	1	1	

Section II  
Limitations

BEECHCRAFT  
Debonair C33  
Bonanza E33 and F33

<b>ATA 100 CHAPTER 33 LIGHTS</b>					
Cockpit and instrument lights	-	*	-	*	-*Lights must be operative.
Landing light	-	*	-	*	-*Per FAR 91
Rotating beacon	-	1	-	1	
Position light	-	3	-	3	
<b>ATA 100 CHAPTER 34 NAVIGATION INSTRUMENTS</b>					
Altimeter	1	1	1	1	
Airspeed indicator	1	1	1	1	
Vertical speed	-	-	*	*	-*Per FAR 135
Magnetic compass	1	1	1	1	

2-26

August 1982

SYSTEM and/or COMPONENT	VFR Day				Remarks and/or Exceptions
	VFR N.ght				
	IFR Day				
	IFR Night				
<b>ATA 100 CHAPTER 34 NAVIGATION INSTRUMENTS (Cont)</b>					
Attitude indicator	-	-	1		
Turn Coordinator	-	-	1		
Directional gyro	-	-	1		
Clock	-	-	1		
Transponder	*	*	*		-*Per FAR 91
Navigation equipment	-	-	*		-*Per FAR 91
<b>ATA 100 CHAPTER 35 OXYGEN</b>					
Oxygen system	*	*	*	*	-*Per FAR 91

<b>ATA 100 CHAPTER 36 PNEUMATIC</b>					
Pressure system for instrument air	-	-	1	1	
Pressure gage	-	-	1	1	
<b>ATA 100 CHAPTER 37 VACUUM</b>					
Vacuum system for instrument air	-	-	1	1	
Vacuum gage	-	-	1	1	
<b>ATA 100 CHAPTER 77 ENGINE INDICATING INSTRUMENTS</b>					
Engine tachometer indicator	1	1	1	1	
Exhaust gas temperature indicator	*	*	*	*	*Optional
Manifold pressure indicator	1	1	1	1	

**Section II  
Limitations**

**BEECHCRAFT  
Debonair C33  
Bonanza E33 and F33**

SYSTEM and/or COMPONENT	VFR Day		VFR Night		Remarks and/or Exceptions
	IFR Day	IFR Night	IFR Day	IFR Night	
ATA 100 CHAPTER 79 ENGINE OIL INSTRUMENTS  Oil pressure indicator Oil temperature indicator	1				
	1		1		
	1		1		
	1		1		

# **SECTION III**

## **EMERGENCY PROCEDURES**

### **TABLE OF CONTENTS**

<i>SUBJECT</i>	<i>PAGE</i>
Emergency Airspeeds .....	3-3
Engine Failure .....	3-4
During Take-Off Ground Roll .....	3-4
After Liftoff and in Flight .....	3-4
Engine Discrepancy Checks .....	3-5
Rough Running Engine .....	3-5
Loss of Engine Power .....	3-5
Air Start Procedure .....	3-5
Engine Fire .....	3-6
In Flight .....	3-6
On The Ground .....	3-6
Maximum Glide Configuration .....	3-6
Emergency Descent .....	3-7
Landing Emergencies .....	3-7
Landing Without Power .....	3-7
Landing Gear Retracted - With Power .....	3-7
Systems Emergencies .....	3-8
Propeller Overspeed .....	3-8
Generator/Alternator-Out Procedure .....	3-8
Engine Instrument Malfunction .....	3-9
Unscheduled Electric Elevator Trim .....	3-9
Landing Gear Manual Extension .....	3-10
Landing Gear Retraction After Practice Manual Extension .....	3-11

**TABLE OF CONTENTS (Continued)**

<i>SUBJECT</i>	<i>PAGE</i>
Induction System Blockage .....	3-11
Emergency Static Air Source System .....	3-11
Emergency Exits .....	3-12
Unlatched Door in Flight .....	3-12
Spins .....	3-13
Emergency Speed Reduction .....	3-13

**EMERGENCY AIRSPEEDS**

Emergency Descent .....	153 kts/176 mph
Glide .....	105 kts/121 mph
Emergency Landing Approach .....	80 kts/92 mph

**CAUTION**

The approach airspeed is higher than normal to assure the availability of control during flare without power.

*All airspeeds quoted in this section are indicated airspeeds (IAS).*

The following information is presented to enable the pilot to form, in advance, a definite plan of action for coping with the most probable emergency situations which could occur in the operation of the airplane. Where practicable, the emergencies requiring immediate corrective action are treated in check list form for easy reference and familiarization. Other situations, in which more time is usually permitted to decide on and execute a plan of action, are discussed at some length.

## **ENGINE FAILURE**

### **DURING TAKE-OFF GROUND ROLL**

1. Throttle - CLOSED
2. Braking - MAXIMUM
3. Fuel Selector Valve - OFF
4. Battery and Generator/Alternator Switches - OFF

### **AFTER LIFTOFF AND IN FLIGHT**

*Landing straight ahead is usually advisable. If sufficient altitude is available for maneuvering, accomplish the following:*

1. Fuel Selector Valve - SELECT OTHER TANK (Check to feel detent)
2. Auxiliary Fuel Pump - ON
3. Mixture - FULL RICH, then LEAN as required
4. Magnetos - CHECK LEFT and RIGHT, then BOTH
5. Alternate Air T-handle - PULL AND RELEASE

### **NOTE**

The most probable cause of engine failure would be loss of fuel flow, improper functioning of the ignition system or blockage of the induction system.

### *If No Restart*

1. Select most favorable landing site.
2. See EMERGENCY LANDING procedure.
3. The use of landing gear is dependent on the terrain where landing must be made.

## **ENGINE DISCREPANCY CHECKS**

### **CONDITION: ROUGH RUNNING ENGINE**

1. Mixture - FULL RICH, then LEAN as required
2. Magneto/Start Switch - CHECK LEFT and RIGHT, then BOTH
3. Alternate Air T-handle - PULL AND RELEASE

### **CONDITION: LOSS OF ENGINE POWER**

1. Fuel Flow Gage - CHECK

*If fuel flow is abnormally low:*

- a. Mixture - FULL RICH
  - b. Auxiliary Fuel Pump - ON (Lean as required)
  - c. Auxiliary Fuel Pump - OFF if performance does not improve in a few moments
2. Fuel Quantity Indicator - CHECK for fuel supply in tank being used
  3. Alternate Air T-handle - PULL AND RELEASE

*If tank being used is empty:*

Fuel Tank Selector Valve - SELECT OTHER FUEL TANK  
(feel for detent and check visually)

## **AIR START PROCEDURE**

- a. Fuel Selector Valve - SELECT TANK MORE NEARLY FULL (check to feel detent)
- b. Throttle - RETARD
- c. Mixture - FULL RICH
- d. Auxiliary Fuel Pump - ON until power is regained, then OFF. (Leave on if engine driven fuel pump is inoperative.)
- e. Throttle - ADVANCE to desired power
- f. Mixture - LEAN as required

## **ENGINE FIRE**

### **IN FLIGHT**

The red VENT SHUTOFF (C33, E33)/FIREWALL AIR (F33) control on the outboard side of the left lower subpanel is used to close off all heating system outlets so that smoke and fumes will not enter the cabin. In the event of engine fire, shut down the engine as follows and make a landing:

1. Vent Shutoff/Firewall Air Control - PULL TO CLOSE
2. Mixture - IDLE CUT-OFF
3. Fuel Selector Valve - OFF
4. Battery, Generator/Alternator Switches - OFF  
(Extending the landing gear can be accomplished manually if desired.)
5. Do not attempt to restart engine.

### **ON THE GROUND**

1. Mixture - IDLE CUT-OFF
2. Fuel Selector Valve - OFF
3. Battery, Generator/Alternator and Magneto Switches - OFF
4. Extinguish with Fire Extinguisher.

## **MAXIMUM GLIDE CONFIGURATION**

1. Landing Gear - UP
2. Flaps - UP
3. Propeller - PULL for LOW RPM
4. Airspeed - 105 kts/121 mph

Glide distance is approximately 1.7 nautical miles (2 statute miles) per 1000 feet of altitude above the terrain.

## **EMERGENCY DESCENT**

1. Power - IDLE
2. Propeller - HIGH RPM
3. Landing Gear - DOWN
4. Airspeed - ESTABLISH 153 kts/176 mph

## **LANDING EMERGENCIES**

### **LANDING WITHOUT POWER**

The approach speed is higher than normal to assure the availability of control during flare without power. When assured of reaching the landing site selected, and on final approach:

1. Airspeed - 80 kts/92 mph
2. Fuel Selector Valve - OFF
3. Mixture - IDLE CUT-OFF
4. Flaps - AS REQUIRED
5. Landing Gear - DOWN OR UP, DEPENDING ON TERRAIN
6. Battery and Generator/Alternator Switches - OFF

### **LANDING GEAR RETRACTED - WITH POWER**

If possible, choose firm sod or foamed runway. Make a normal approach, using flaps as necessary. When you are sure of making the selected landing spot:

1. Throttle - CLOSED
2. Mixture - IDLE CUT-OFF
3. Battery and Generator/Alternator Switches - OFF
4. Fuel Selector Valve - OFF
5. Keep wings level during touchdown.
6. Get clear of the airplane as soon as possible after it stops.

## **SYSTEMS EMERGENCIES**

### **PROPELLER OVERSPEED**

1. Throttle - RETARD TO RPM RED LINE
2. Airspeed - REDUCE
3. Oil Pressure - CHECK

#### **WARNING**

If loss of oil pressure was the cause of over-speed, the engine will seize after a short period of operation.

4. Land - SELECT NEAREST SUITABLE SITE and follow LANDING EMERGENCIES procedure.

### **GENERATOR/ALTERNATOR OUT PROCEDURE**

A failure of the generator/alternator will place the entire electrical operation of the aircraft on the battery. Failure may be indicated by the ammeter. When a failure occurs in flight, all non-essential electrical load should be discontinued to conserve the battery life.

#### ***ALTERNATOR OVERVOLTAGE***

*If an alternator overvoltage condition occurs in flight:*

1. Battery Switch and Alternator Switch - OFF MOMENTARILY, THEN ON (this resets overvoltage relay)

If overvoltage condition does not recur, continue to use the alternator.

*If overvoltage condition persists:*

2. Alternator Switch - OFF
3. Nonessential Electrical Equipment - OFF to conserve battery power.

## **ENGINE INSTRUMENT MALFUNCTION**

In event of engine instrument malfunction, maintain the last known rpm and manifold pressure setting and proceed to the nearest suitable airfield and land. If a higher power setting is required, select maximum rpm and enrichen mixture appropriately.

### ***CAUTION***

At high altitudes and low power settings, full rich mixtures may result in poor engine operation. Adjust the mixture for smooth engine operation upon power reduction.

## **UNSCHEDULED ELECTRIC ELEVATOR TRIM**

1. Airplane Attitude - **MAINTAIN** using elevator control.
2. Elevator Trim Thumb Switch (On Control Wheel) - **MOVE IN DIRECTION OPPOSITE UNSCHEDULED PITCH TRIM** to open circuit breaker.
3. Elevator Trim ON-OFF Switch (On Instrument Panel) - **OFF**
4. Manual Elevator Trim Control Wheel - **RETRIM AS DESIRED.**

### **NOTE**

Do not attempt to operate the electric trim system until the cause of the malfunction has been determined and corrected.

## **LANDING GEAR MANUAL EXTENSION**

Manual extension of the landing gear can be facilitated by first reducing airspeed. Then proceed as follows:

1. LDG GEAR Circuit Breaker - OFF (PULL OUT)
2. Landing Gear Switch Handle - DOWN position
3. Handcrank Handle Cover (at rear of front seats) - REMOVE
4. Handcrank - ENGAGE and TURN COUNTERCLOCKWISE AS FAR AS POSSIBLE (approximately 50 turns)

### ***CAUTION***

The manual extension system is designed to lower the landing gear only. **DO NOT ATTEMPT TO RETRACT THE GEAR MANUALLY.**

5. If electrical system is operative, check landing gear position lights and warning horn (check LDG GEAR INDICATOR and LDG GEAR WARNING circuit breakers engaged).
6. Check mechanical landing gear indicator - DOWN
7. Handcrank - DISENGAGE. Always keep it stowed when not in use.

### **WARNING**

Do not operate the landing gear electrically with the handcrank engaged, as damage to the mechanism could occur. After emergency landing gear extension, do not move any landing gear controls or reset any switches or circuit breakers until airplane is on jacks as failure may have been in the gear up circuit and gear might retract on the ground.

### **LANDING GEAR RETRACTION AFTER PRACTICE MANUAL EXTENSION**

After practice manual extension of the landing gear, the gear may be retracted electrically, as follows:

1. Handcrank - CHECK, STOWED
2. Landing Gear Motor Circuit Breaker - IN
3. Landing Gear - RETRACT

### **INDUCTION SYSTEM BLOCKAGE**

An alternate induction air door, spring-loaded to the closed position, is located downstream from the induction air filter. If the induction air filter becomes blocked (e.g., ice, etc.), the differential air pressure normally opens the alternate induction air door to provide induction air from the bottom of the engine compartment. If the alternate induction air door becomes stuck in the closed position, it can be opened by pulling and releasing the T-handle located directly below the propeller control knob. This T-handle is placarded ALTERNATE AIR PULL AND RELEASE.

### **EMERGENCY STATIC AIR SOURCE SYSTEM**

THE EMERGENCY STATIC AIR SOURCE SHOULD BE USED FOR CONDITIONS WHERE THE NORMAL STATIC SOURCE HAS BEEN OBSTRUCTED. When the airplane has been exposed to moisture and/or icing conditions (especially on the ground), the possibility of obstructed static ports should be considered. Partial obstructions will result in the rate of climb indication being sluggish during a climb or descent. Verification of suspected obstruction is possible by switching to the emergency system and noting a sudden sustained change in rate of climb. This may be accompanied by abnormal indicated airspeed and altitude changes beyond normal calibration differences.

**Section III  
Emergency Procedures**

**BEECHCRAFT  
Debonair C33  
Bonanza E33 and F33**

Whenever any obstruction exists in the Normal Static Air System or the Emergency Static Air System is desired for use:

1. Pilot's Emergency Static Air Source - Switch to ON EMERGENCY.
2. For Airspeed Calibration and Altimeter Correction, refer to PERFORMANCE section.

**CAUTION**

Be certain the emergency static air valve is in the NORMAL position when system is not needed.

**EMERGENCY EXITS (E33, F33 WITH OPTIONAL OPENABLE CABIN WINDOWS)**

Emergency exits, provided by the openable window on each side of the cabin, may be used for egress in addition to the cabin door. An emergency exit placard is installed below the left and right middle windows.

To open each emergency exit:

1. Lift the latch.
2. Pull out the emergency release pin and push the window out.

**UNLATCHED DOOR IN FLIGHT**

If the cabin door is not locked it may come unlatched in flight. This may occur during or just after take-off. The door will trail in a position approximately 3 inches open, but the

flight characteristics of the airplane will not be affected, except that rate of climb will be reduced. Return to the field in a normal manner. If practicable, during the landing flare-out have a passenger hold the door to prevent it from swinging open.

## **SPINS**

Spins are prohibited. If a spin is entered inadvertently:

Immediately move the control column full forward and simultaneously apply full rudder opposite to the direction of the spin; continue to hold this control position until rotation stops and then neutralize all controls and execute a smooth pullout. Ailerons should be neutral and throttle in idle position at all times during recovery.

## **EMERGENCY SPEED REDUCTION**

In an emergency, the landing gear may be used to create additional drag. Should disorientation occur under instrument conditions, the lowering of the landing gear will reduce the tendency for excessive speed build-up. This procedure would also be appropriate for a non-instrument rated pilot who unavoidably encounters instrument conditions or in other emergencies such as severe turbulence.

Should the landing gear be used at speeds higher than the maximum extension speed, a special inspection of the gear doors in accordance with shop manual procedures is required, with repair as necessary.

**INTENTIONALLY LEFT BLANK**

# **SECTION IV**

## **NORMAL PROCEDURES**

### **TABLE OF CONTENTS**

<i>SUBJECT</i>	<i>PAGE</i>
Airspeeds for Safe Operation .....	4-3
Preflight Inspection .....	4-3
Before Starting .....	4-6
External Power .....	4-7
Starting Engine Using Auxiliary Power Unit .....	4-8
Starting .....	4-8
After Starting and Taxi .....	4-10
Before Takeoff .....	4-10
Takeoff .....	4-12
Climb .....	4-12
Cruise .....	4-12
Leaning Using the Exhaust Gas Temperature Indicator (EGT) .....	4-13
Descent .....	4-14
Before Landing .....	4-14
Balked Landing .....	4-15
After Landing .....	4-15
Shutdown .....	4-15
Environmental Systems .....	4-16
Oxygen System .....	4-16
Preflight .....	4-16
Oxygen Duration .....	4-17
Oxygen Duration Chart .....	4-17
In Flight .....	4-18

**TABLE OF CONTENTS (Continued)**

<i>SUBJECT</i>	<i>PAGE</i>
After Using .....	4-18
Heating and Ventilation .....	4-18
Cold Weather Operation .....	4-19
Icing Conditions .....	4-20
Engine Break-in Information .....	4-20

**BEECHCRAFT  
Debonair C33  
Bonanza E33 and F33**

**Section IV  
Normal Procedures**

*All airspeeds quoted in this section are indicated airspeeds (IAS)*

**AIRSPEEDS FOR SAFE OPERATION**

Take-off	
Lift-off	68 kts/78 mph
50 Ft.	74 kts/85 mph
Maximum Climb	
Best Rate ( $V_y$ )	90 kts/104 mph
Best Angle ( $V_x$ )	74 kts/85 mph
Cruise Climb	104 kts/120 mph
Maximum Turbulent Air Penetration	128 kts/147 mph
Balked Landing	70 kts/81 mph
Landing Approach	70 kts/81 mph
Maximum Demonstrated Crosswind	17 kts/20 mph

**PREFLIGHT INSPECTION**

Emergency Locator Transmitter - ARMED  
Location may vary with individual airplanes

**1. CABIN:**

- a. Parking Brake - SET
- b. Control Lock - REMOVE
- c. All Switches - OFF

**2. RIGHT FUSELAGE:**

- a. Baggage Compartment Door - SECURE
- b. Static Pressure Button - UNOBSTRUCTED

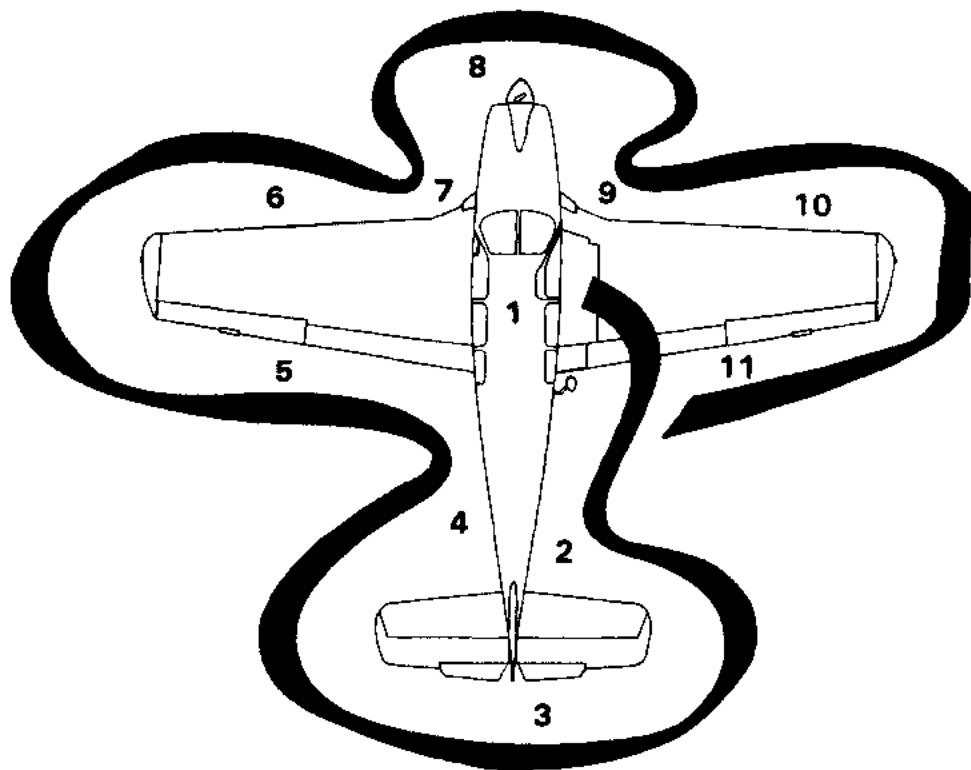

**3. EMPENNAGE:**

- a. Control Surfaces - CHECK
- b. Tie Down - REMOVE
- c. Position Light - CHECK
- d. Cabin Air Intake - CHECK (E33, F33)

**4. LEFT FUSELAGE:**

- a. Static Pressure Button - UNOBSTRUCTED
- b. All Antennas - CHECK

5. LEFT WING TRAILING EDGE:
  - a. Flap - CHECK
  - b. Aileron - CHECK
  - c. Wing Tip - CHECK
  - d. Position Light - CHECK
  
6. LEFT WING LEADING EDGE:
  - a. Stall Warning - CHECK
  - b. Pitot Tube - CHECK (Remove Cover)
  - c. Fuel Tank - CHECK QUANTITY; Filler Cap - SECURE.
  - d. Cabin Air Intake - CHECK
  - e. Tie Down and Chocks - REMOVE
  
7. LEFT LANDING GEAR:
  - a. Wheel Well Door, Tire and Strut - CHECK
  - b. Fuel Vent - CHECK
  - c. Fuel Sump - DRAIN
  - d. Fuel Selector Valve Sump - DRAIN; Cover - SECURE
  
8. NOSE SECTION:
  - a. Engine Oil - CHECK (See Servicing, Section 8) Cap and Dipstick - SECURE
  - b. Left Cowl - SECURE
  - c. Propeller - CHECK, General Condition, Nicks, etc.
  - d. Landing Light - CHECK
  - e. Wheel Well Doors, Tire and Strut - CHECK
  - f. Induction Air Intake - CLEAR
  - g. Engine - CHECK GENERAL CONDITION
  - h. Right Cowl - SECURE
  - i. Chocks - REMOVE

**Section IV  
Normal Procedures**

**BEECHCRAFT  
Debonair C33  
Bonanza E33 and F33**

9. RIGHT LANDING GEAR:
  - a. Fuel Vent - CHECK
  - b. Fuel Sump - DRAIN
  - c. Wheel Well Door, Tire and Strut - CHECK
  
10. RIGHT WING LEADING EDGE:
  - a. Cabin Air Intake - CHECK
  - b. Tie Down and Chocks - REMOVE
  - c. Fuel Tank - CHECK QUANTITY; Filler Cap - SECURE
  
11. RIGHT WING TRAILING EDGE:
  - a. Position Light - CHECK
  - b. Wing Tip - CHECK
  - c. Aileron - CHECK
  - d. Flap - CHECK

***CAUTION***

**NEVER TAXI IF ANY STRUT IS FLAT.**

**BEFORE STARTING**

1. Seats - POSITION AND LOCK; Seat Backs - UPRIGHT
2. Seat Belts - FASTEN
3. Parking Brake - SET
4. All Avionics - OFF
5. Circuit Breakers - IN
6. Landing Gear Handle - DOWN
7. Flaps - UP
8. Light Switches - As required
9. Electric Elevator Trim Switch - OFF (If installed)
10. Fuel Selector Valve - CHECK OPERATION; SELECT TANK MORE NEARLY FULL

11. Battery and Generator/Alternator Switches - ON (If external power is used, turn Generator/Alternator Switch - OFF. See Section 7 and the precautions below.)
12. Fuel Quantity Indicators - CHECK QUANTITY

### **WARNING**

Do not take off if gages indicate in yellow arc or with less than 13 gallons in each tank.

### **EXTERNAL POWER**

When using external power, it is very important that the following precautions be observed:

1. The airplane has a negative ground system. Exercise care to avoid reversed polarity. Be sure to connect the positive lead of the external power unit to the positive terminal of the airplane's external power receptacle and the negative lead to the negative terminal of the external power receptacle. A positive voltage must also be applied to the small guide pin.
2. To prevent arcing, make certain no power is being supplied when the connection is made.
3. Make certain that the battery switch is ON, all avionics and electrical switches OFF, and a battery is in the system before connecting an external power unit. This protects the voltage regulators and associated electrical equipment from voltage transients (power fluctuations).

**STARTING ENGINE USING AUXILIARY POWER UNIT**

1. Battery Switch - ON
2. Generator/Alternator, Electrical, and Avionics Equipment - OFF
3. Auxiliary Power Unit - CONNECT
4. Auxiliary Power Unit - SET OUTPUT (13.5 to 14.25 volts)
5. Auxiliary Power Unit - ON
6. Engine - START using normal procedures
7. Auxiliary Power Unit - OFF (after engine has been started)
8. Auxiliary Power Unit - DISCONNECT
9. Generator/Alternator Switch - ON

**STARTING**

*CAUTION*

Vernier-type engine controls should not be rotated clockwise after being advanced to the full forward position.

1. Mixture - FULL RICH
2. Propeller - HIGH RPM
3. Throttle - Approximately 1/2 inch open

**NOTE**

If the engine is hot, and the ambient temperature is 90°F or above, place mixture control in IDLE CUT-OFF, switch auxiliary fuel pump to ON for 30 to 60 seconds, then OFF. Return mixture control to FULL RICH.

4. Magneto/Start Switch - BOTH

5. Auxiliary Fuel Pump - On until fuel flow peaks then OFF
6. Throttle - Approximately 1/4 inch open.
7. Magneto/Start Switch - START position; release to BOTH position when engine fires

**CAUTION**

Do not engage starter for more than 30 seconds in any 4-minute period.

8. In Event of Overprime Condition:
  - a. Mixture - IDLE CUT-OFF
  - b. Throttle - OPEN
  - c. Magneto/Start Switch - START position
  - d. As engine fires, reduce throttle to IDLE and advance the mixture control to FULL RICH

**NOTE**

During hot starts, the Auxiliary Fuel Pump is turned on momentarily after starting to purge system, then turned off.

9. Throttle - 1000 to 1200 rpm.
10. Oil Pressure - CHECK
11. External Power (if used) - DISCONNECT. Battery and Generator/Alternator Switches ON
12. All Engine Indicators - CHECK

**CAUTION**

The ammeter indication should be less than 25% of full charge at 1000 to 1200 rpm within two minutes, with no additional electrical equipment on. If not, turn off the battery and alternator switches and do not take off.

**AFTER STARTING, AND TAXI**

1. Brakes - RELEASE AND CHECK
2. Avionics Equipment - ON, AS REQUIRED
3. Lights - AS REQUIRED

*CAUTION*

Do not operate engine above 1200 RPM until oil temperature reaches 75°F (24°C).

**BEFORE TAKEOFF**

1. Parking Brake - SET
2. Seat Belts and Shoulder Harnesses - CHECK

**NOTE**

All reclining seats must be in the upright position during takeoff.

3. Avionics - CHECK
4. Engine Instruments - CHECK
5. Flight Instruments - CHECK AND SET
6. Ammeter - CHECK - for stabilized indication between 0 and 25% of full charge at 1000 to 1200 rpm.
7. Auxiliary Fuel Pump - CHECK OFF

8. Throttle - 1900 RPM
9. Propeller - EXERCISE to obtain 300 to 400 rpm drop; return to high rpm
10. Magnetos - CHECK at 1700 rpm (variance between individual magnetos should not exceed 50 rpm, maximum drop not to exceed 150 rpm.)
11. Trim - SET
  - a. Aileron - NEUTRAL (if installed)
  - b. Elevator - 0° (3° nose up if only front seats are occupied)
12. Flaps - Check operation, then UP
13. Door and Windows - SECURE
14. Flight Controls - CHECK PROPER DIRECTION, FULL TRAVEL AND FREEDOM OF MOVEMENT
15. Mixture - FULL RICH (or as required by field elevation)
16. Brakes - RELEASED
17. Instruments - CHECK (Make final check of manifold pressure, fuel flow, and rpm at the start of the take-off run.)

**TAKE-OFF**

Take-Off Power ..... Full Throttle, 2600 rpm

1. Power - SET TAKE-OFF POWER (Mixture - SET as required by field elevation)
2. Brakes - RELEASE THEN ACCELERATE to recommended speeds
3. Landing Gear - RETRACT (when positive rate of climb is established and insufficient runway remains for landing)
4. Airspeed - ESTABLISH DESIRED CLIMB SPEED (when clear of obstacles)

**CLIMB**

Maximum Continuous ..... Full throttle, 2600 rpm

Cruise Climb ..... 25 in. Hg (or full throttle) 2500 rpm

1. Engine Temperatures - MONITOR
2. Power - SET AS DESIRED.
3. Mixture - SET FUEL FLOW

**CRUISE**

See Cruise Charts in PERFORMANCE Section.

1. Power - SET
2. Mixture - SET FUEL FLOW

## **LEANING USING THE EXHAUST GAS TEMPERATURE INDICATOR (EGT)**

A thermocouple-type exhaust gas temperature (EGT) probe is mounted in the exhaust system. This probe is connected to an indicator on the instrument panel. The indicator is calibrated in degrees Fahrenheit. Use EGT system to lean the fuel/air mixture when cruising at 75% power or less in the following manner:

1. Lean the mixture and note the point on the indicator that the temperature peaks and starts to fall.
  - a. CRUISE (LEAN) MIXTURE - Increases the mixture until the EGT shows a drop of 25°F below peak on the rich side of peak.
  - b. BEST POWER MIXTURE - Increase the mixture until the EGT shows a drop of 100°F below peak on the rich side of peak.

### *CAUTION*

Do not continue to lean mixture beyond that necessary to establish peak temperature.

2. Continuous operation is recommended at 25°F or more below peak EGT only on the rich side of peak.
3. Changes in altitude and power settings require the peak EGT to be rechecked and the mixture reset.

**DESCENT**

1. Altimeter - SET
2. Power - AS REQUIRED (avoid prolonged idle settings and low cylinder head temperatures)
3. Mixture - ENRICH AS REQUIRED

**BEFORE LANDING**

1. Seat Belts - SECURE

**NOTE**

All reclining seats must be in the upright position during landing.

2. Fuel Selector Valve - SELECT TANK MORE NEARLY FULL
3. Mixture - FULL RICH (or as required by field elevation)
4. Landing Gear - DOWN and CHECK. (Observe maximum extension speed)
5. Landing Light - AS REQUIRED
6. Flaps - DOWN (Observe maximum extension speed)
7. Airspeed - ESTABLISH LANDING APPROACH SPEED.
8. Propeller - HIGH RPM
9. Electric Elevator Trim Switch - OFF (if installed)

### **BALKED LANDING**

1. Power - FULL THROTTLE, 2600 RPM
2. Airspeed - 70 kts/81 mph until clear of obstacles, then trim to normal climb speed
3. Landing Gear - UP
4. Flaps - UP

### **AFTER LANDING**

1. Landing Light - AS REQUIRED
2. Flaps - UP
3. Trim Tab - SET TO 0°

### **SHUTDOWN**

1. Brakes - SET
2. Electrical and Radio Equipment - OFF
3. Throttle - CLOSE
4. Mixture - IDLE CUT-OFF
5. Magneto/Start Switch - OFF, after engine stops
6. Battery and Generator/Alternator Switches - OFF
7. Control Lock - INSTALL, if conditions warrant.
8. Install wheel chocks and release brakes if the airplane is to be left unattended.

**ENVIRONMENTAL SYSTEMS**

**OXYGEN SYSTEM**

*PREFLIGHT*

1. Check Oxygen Pressure Gage for pressure reading.
2. Determine percent of full system.
3. Multiply oxygen duration in minutes by percent of full bottle.

**EXAMPLE:**

People .....	5
Gage Pressure .....	1500 psig
Oxygen Available (from chart) .....	80%
Cylinder Capacity (full) .....	49 cu ft
Altitude (planned flight) .....	15,000 ft
Full Bottle Duration (from chart) .....	149 min
Duration (80% full) .....	119 min

**OXYGEN AVAILABLE WITH  
PARTIALLY FULL BOTTLE**

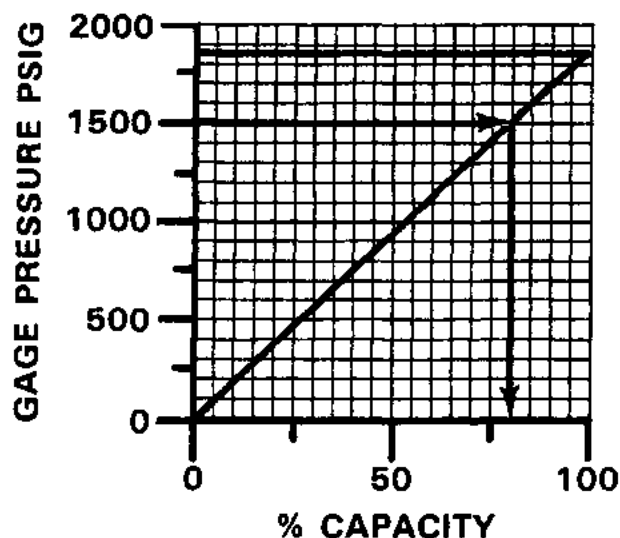

***OXYGEN DURATION***

The recommended masks are provided with the system. They are designed to be adjustable to fit the average person, with minimum leakage of oxygen.

***CAUTION***

Since 90% of the system efficiency is determined by the fit of the oxygen mask, make certain the masks fit properly and are in good condition.

***OXYGEN DURATION CHART (Full Bottle)***

Duration in minutes at the following altitudes:

<b>Bottle Capacity</b>	<b>Persons Using</b>	<b>12,500 FT</b>	<b>15,000 FT</b>	<b>20,000 FT</b>
49 cu ft	1	1014	746	507
	2	507	373	253
	3	338	248	169
	4	253	186	126
	5	202	149	101

**NOTE**

To calculate duration times for bottle capacities other than 49 cu. ft. use 77% (38 cu. ft.) or 230% (114 cu. ft.) of chart values.

**WARNING**

**NO SMOKING** when using oxygen.

*IN FLIGHT*

The use of oxygen is recommended to be in accordance with current FAR operating rules.

1. Oxygen Control Valve - OPEN SLOWLY
2. Mask - INSERT FITTING, DON MASK (adjust mask for proper fit)
3. Oxygen - CHECK INDICATOR FOR FLOW

*AFTER USING*

1. Discontinue use by unplugging mask from outlet.

**NOTE**

Closing the control valve while in flight is not necessary due to automatic sealing of the outlet when the mask is unplugged. However, it is desirable to shut off supply when not in use.

2. Oxygen Control Valve - CLOSED (may be accomplished during shut-down)

**HEATING AND VENTILATION**

Refer to the SYSTEMS DESCRIPTION Section for operation of heating and ventilation controls.

## **COLD WEATHER OPERATION**

### **PREFLIGHT INSPECTION**

All accumulations of ice, snow and frost must be removed from the wings, tail, control surfaces and hinges, propeller, windshield, fuel cell filler caps, crankcase vents, and fuel vents. If such accumulations are not removed completely, the airplane shall not be flown. The deposits will not blow off in flight. While an adverse weight factor is clearly involved in the case of heavy deposits, it is less obvious that even slight accumulations will disturb or completely destroy the designed aerodynamic properties of the airfoils.

The normal preflight procedures should then be completed, with particular attention given to check of flight controls for complete freedom of movement.

### **ENGINE**

Use engine oil in accordance with Consumable Materials in the HANDLING, SERVICING AND MAINTENANCE Section. Always pull the propeller through by hand, opposite the direction of rotation, several times to clear the engine and "limber up" the cold, heavy oil before using the starter. This will also lessen the load on the battery if external power is not used.

Under very cold conditions, it may be necessary to preheat the engine prior to a start. Particular attention should be given to the oil cooler, engine sump and propeller hub to ensure proper preheat. A start with congealed oil in the system may produce an indication of normal pressure immediately after the start, but then the oil pressure may de-

crease when residual oil in the engine is pumped back with the congealed oil in the sump. If an engine heater capable of heating both the engine sump and cooler is not available, the oil should be drained while the engine is hot and stored in a warm area until the next flight.

If there is no oil pressure within the first 30 seconds of running, or if oil pressure drops after a few minutes of ground operation, shut down and check for broken oil lines, oil cooler leaks or the possibility of congealed oil.

#### **NOTE**

It is advisable to use external power for starting in cold weather.

During warm-up, monitor engine temperatures closely, since it is quite possible to exceed the cylinder head temperature limit in trying to bring up the oil temperature. Exercise the propeller several times to remove cold oil from the pitch change mechanism. The propeller should also be cycled occasionally in flight.

During letdown and landing, give special attention to engine temperatures, since the engine will have a tendency toward overcooling.

#### **ICING CONDITIONS**

Flight in Icing Conditions Is Prohibited.

#### **ENGINE BREAK-IN INFORMATION**

See Systems Description section

# **SECTION V**

## **PERFORMANCE**

### **TABLE OF CONTENTS**

<i>SUBJECT</i>	<i>PAGE</i>
Introduction to Performance and Flight Planning .....	5-3
Conditions .....	5-3
Comments Pertinent to the Use of Performance Graphs .....	5-9
Airspeed Calibration - Normal System .....	5-10
Altimeter Correction - Normal System .....	5-11
Airspeed Calibration - Emergency System .....	5-12
Altimeter Correction - Emergency System .....	5-13
Temperature Conversion .....	5-14
ISA Conversion .....	5-15
Stall Speeds - Power Idle .....	5-16
Wind Components .....	5-17
Take-Off Distance .....	5-18
Climb .....	5-19
Time, Fuel and Distance to Climb .....	5-20
Cruise Power Settings	
75% MCP (Or Full Throttle) .....	5-21
65% MCP (Or Full Throttle) .....	5-22
55% MCP (Or Full Throttle) .....	5-23
45% MCP (Or Full Throttle) .....	5-24
Cruise Speeds .....	5-25
Manifold Pressure vs RPM .....	5-26
Fuel Flow vs Brake Horsepower .....	5-27

**TABLE OF CONTENTS (Continued)**

<i>SUBJECT</i>	<i>PAGE</i>
Range Profile - 74 Gallons .....	5-28
Range Profile - 44 Gallons .....	5-29
Endurance Profile - 74 Gallons .....	5-30
Endurance Profile - 44 Gallons .....	5-31
Landing Distance .....	5-32

**INTRODUCTION TO PERFORMANCE AND FLIGHT  
PLANNING**

The graphs and tables in this section present performance information for flight planning at various parameters of weight, power, altitude and temperature. Examples have been presented on all performance graphs. In addition, the calculations for flight time, block speed and fuel required for a proposed flight are detailed below. All examples and calculations utilize the following conditions:

**CONDITIONS**

At Denver:

Outside Air Temperature ..... 15°C (59°F)  
 Field Elevation ..... 5330 ft  
 Altimeter Setting ..... 29.60 in. Hg  
 Wind ..... 270° at 10 kts  
 Runway 26L length ..... 10,010 ft

Route of Trip

\*DEN-V81-AMA

For VFR Cruise at 11,500 feet

ROUTE SEGMENT	MAGNETIC COURSE	DIST NM	WIND 11500 FEET DIR/KTS	OAT 11500 FEET °C	ALT SETTING IN.HG
DEN-COS	161°	55	010/30	-5	29.60
COS-PUB	153°	40	010/30	-5	29.60
PUB-TBE	134°	74	100/20	0	29.56
TBE-DHT	132°	87	200/20	9	29.56
DHT-AMA	125°	65	200/20	10	29.56

\*REFERENCE: Enroute Low Altitude Chart L-6

**Section V  
Performance**

**BEEHCRAFT  
Debonair C33  
Bonanza E33 and F33**

At Amarillo:

Outside Air Temperature ..... 25°C (77°F)  
Field Elevation ..... 3605 ft  
Altimeter Setting ..... 29.56 in. Hg  
Wind ..... 180° at 10 kts  
Runway 21 Length ..... 13500 ft

To determine pressure altitude at origin and destination airports, add 100 feet to field elevation for each .1 in. Hg below 29.92, and subtract 100 feet from field elevation for each .1 in. Hg above 29.92.

Pressure Altitude at DEN:

$$29.92 - 29.60 = .32 \text{ in. Hg}$$

The pressure altitude at DEN is 320 feet above the field elevation.

$$5330 + 320 = 5650 \text{ ft}$$

Pressure Altitude at AMA:

$$29.92 - 29.56 = .36 \text{ in. Hg}$$

The pressure altitude at AMA is 360 feet above the field elevation.

$$3605 + 360 = 3965 \text{ ft}$$

**NOTE**

For flight planning, the difference between cruise altitude and cruise pressure altitude has been ignored.

**BEECHCRAFT  
Debonair C33  
Bonanza E33 and F33**

**Section V  
Performance**

Calculations for flight time, block speed and fuel requirement:

Cruise Climb:

Enter the graph for TIME, FUEL AND DISTANCE TO CLIMB at 15°C to 5650 ft and to 3050 lbs. Enter at -5°C to 11,500 ft and to 3050 lbs. Read:

$$\text{Time to Climb} = (22 - 9) = 13 \text{ min}$$

$$\text{Fuel Used to Climb} = (6.1 - 2.6) = 3.5 \text{ gal}$$

$$\text{Distance Traveled} = (42 - 17) = 25 \text{ NM}$$

The cruise power setting is assumed to be at 2450 rpm. Since cruise at 11,500 feet requires full throttle, the manifold pressure and fuel flow should be read from either the cruise power setting table for 75 percent or 65 percent maximum continuous power.

The temperatures for cruise are presented for a standard day (ISA); 20°C (36°F) above a standard day (ISA + 20°C); and 20°C (36°F) below a standard day (ISA - 20°C). These should be used for flight planning. The IOAT values are true temperature values which have been adjusted for the compressibility effects. IOAT should be used for setting cruise power while enroute.

Enter the graph for ISA conversion at 11,500 feet and the temperature for the route segment:

DEN-PUB	OAT	=	-5°C
	ISA Condition	=	ISA + 3°C
PUB-TBE	OAT	=	0°C
	ISA Condition	=	ISA + 8°C
TBE-DHT	OAT	=	9°C
	ISA Condition	=	ISA + 17°C
DHT-AMA	OAT	=	10°C
	ISA Condition	=	ISA + 18°C

**Section V  
Performance**

**BEECHCRAFT  
Debonair C33  
Bonanza E33 and F33**

Enter the cruise power settings table for 75% maximum continuous power (or full throttle) at 10,000 ft, 12,000 ft, ISA and ISA + 20°C.

ALTI- TUDE FEET	TEMPERATURE					
	ISA			ISA + 20°C		
	MAN. PRESS. IN. HG	FUEL FLOW PSI/ GPH	TAS KNOTS	MAN. PRESS. IN. HG	FUEL FLOW PSI/ GPH	TAS KNOTS
10000	20.1	6.6/12.0	154	20.1	6.1/11.2	152
12000	18.6	6.0/11.0	151	18.6	5.6/10.5	148

Interpolate for 11,500 feet and the temperature for the appropriate route segment. Results of the interpolations are:

ROUTE SEGMENT	MAN. PRESS. IN. HG	FUEL FLOW PSI/GPH	TAS KNOTS
DEN-PUB	19.0	6.1/11.2	152
PUB-TBE	19.0	6.0/11.0	151
TBE-DHT	19.0	5.8/10.8	149
DHT-AMA	19.0	5.7/10.7	149

**NOTE**

The above are exact values for the assumed conditions.

**BEECHCRAFT  
Debonair C33  
Bonanza E33 and F33**

**Section V  
Performance**

Time and fuel used were calculated as follows:

$$\text{Time} = \frac{\text{Distance}}{\text{Ground Speed}}$$

$$\text{Fuel Used} = (\text{Time}) (\text{Fuel Flow})$$

Results are:

ROUTE SEGMENT	DISTANCE NM	EST GROUND SPEED KNOTS	TIME AT CRUISE ALTITUDE HRS: MIN	FUEL USED FOR CRUISE GAL
DEN-COS	*30	181	0:10	1.9
COS-PUB	40	179	0:13	2.4
PUB-TBE	74	136	0:33	6.1
TBE-DHT	87	136	0:38	6.8
DHT-AMA	65	139	0:28	5.0

\*Distance required to climb has been subtracted from segment distance.

**TIME - FUEL - DISTANCE**

ITEM	TIME HRS: MINS	FUEL GAL	DISTANCE NM
Start, Runup, Taxi and Take-off acceleration	0:00	1.7	0
Climb	0:13	3.5	25
Cruise	2:02	22.2	296
Total	2:15	27.4	321

**Section V  
Performance**

**BEECHCRAFT  
Debonair C33  
Bonanza E33 and F33**

Total Flight Time: 2 hours, 15 minutes

Block Speed:  $321 \text{ NM} \div 2 \text{ hours, 15 minutes} = 143 \text{ knots}$

Reserve Fuel (45 minutes at 45% maximum continuous power)

Enter the cruise power settings table for 45% MCP (or full throttle). The fuel flow for 45% MCP is 8.3 gallons per hour.

Reserve fuel =  $(45 \text{ min}) (8.3 \text{ GPH}) = 6.2 \text{ gallons}$

Total Fuel =  $27.4 + 6.2 = 33.6 \text{ gallons}$

The estimated landing weight is determined by subtracting the fuel required for the trip from the ramp weight:

Assumed ramp weight = 3060 lbs

Estimated fuel from DEN to AMA =  $(27.4 \text{ gal}) (6 \text{ lbs/gal})$   
= 164 lbs

Estimated landing weight =  $3060 - 164 = 2896 \text{ lbs}$

Examples have been provided on the performance graphs. The above conditions have been used throughout. Rate of climb was determined for the initial cruise altitude conditions.

**COMMENTS PERTINENT TO THE USE OF  
PERFORMANCE GRAPHS**

1. The example, in addition to presenting an answer for a particular set of conditions, also presents the order in which the graphs should normally be used, i.e., if the first item in the example is OAT, then enter the graph at the known OAT.
2. The reference lines indicate where to begin following guide lines. Always project to the reference line first, then follow the guide lines to the next known item.
3. Indicated airspeeds (IAS) were obtained by using the AIRSPEED CALIBRATION NORMAL SYSTEM Graph.
4. The associated conditions define the specific conditions from which performance parameters have been determined. They are not intended to be used as instructions, however, performance values determined from charts can only be achieved if specified conditions exist.
5. The full amount of usable fuel is available for all approved flight conditions.

# AIRSPEED CALIBRATION - NORMAL SYSTEM

NOTE: INDICATED AIRSPEED ASSUMES ZERO INSTRUMENT ERROR

EXAMPLE:

IAS	70 KNOTS (81 MPH)
FLAPS	DOWN
CAS	89 KNOTS (78 MPH)

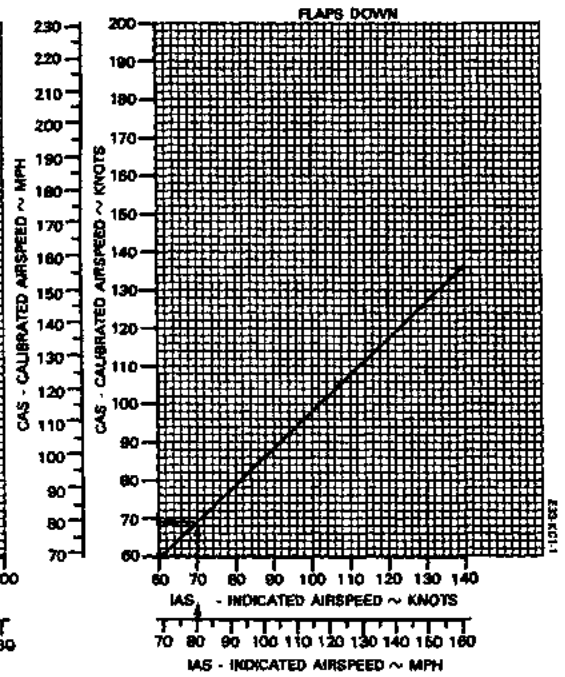
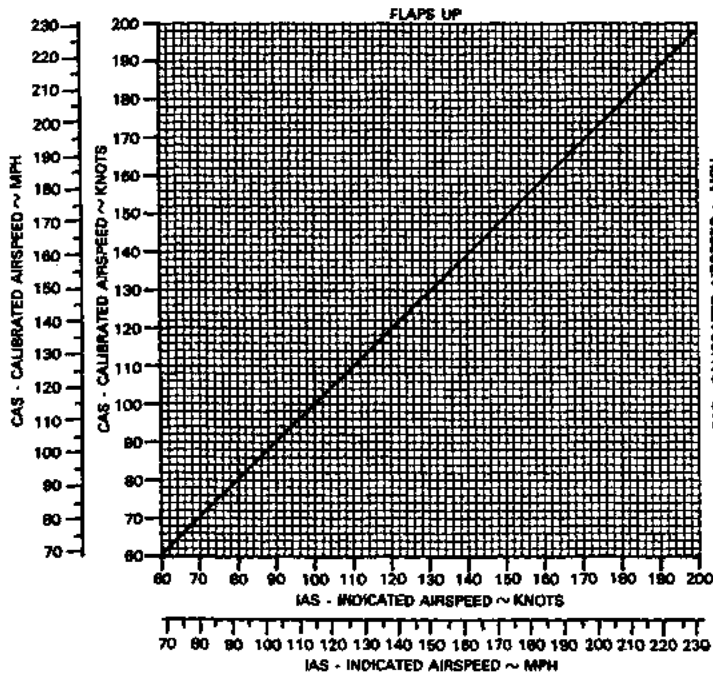

**ALTIMETER CORRECTION - NORMAL SYSTEM**

NOTE: INDICATED AIRSPEED AND INDICATED ALTITUDE ASSUME ZERO INSTRUMENT ERROR

EXAMPLE:

IAS	70 KNOTS (81 MPH)
FLAPS	DOWN
INDICATED PRESSURE ALTITUDE	4500 FT
ALTIMETER CORRECTION	-8 FT
<b>ACTUAL PRESSURE ALTITUDE:</b>	
= 4500 - 8 = 4492 FT	

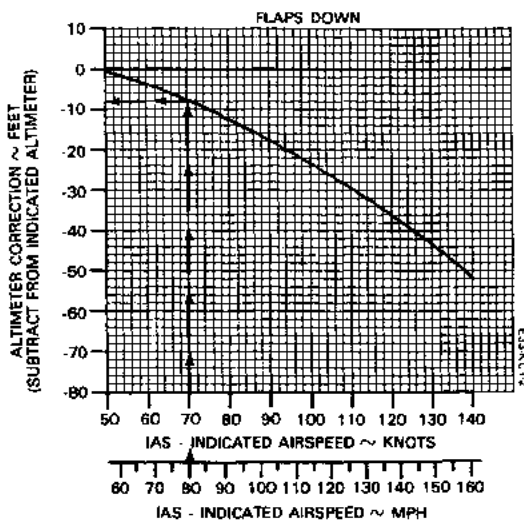
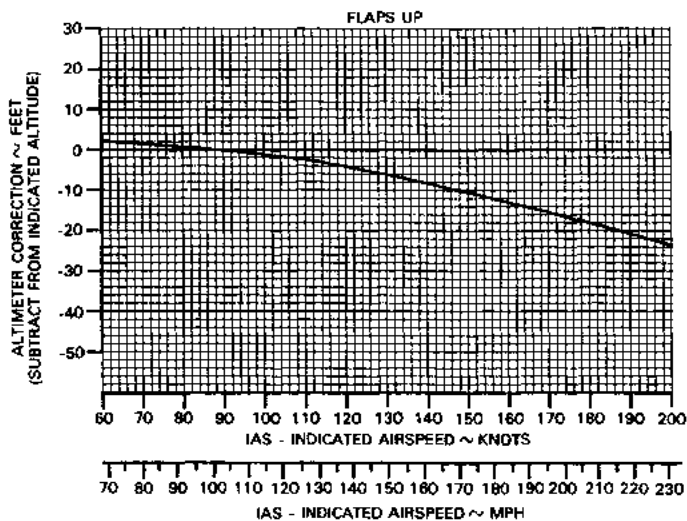

### AIRSPEED CALIBRATION - EMERGENCY SYSTEM

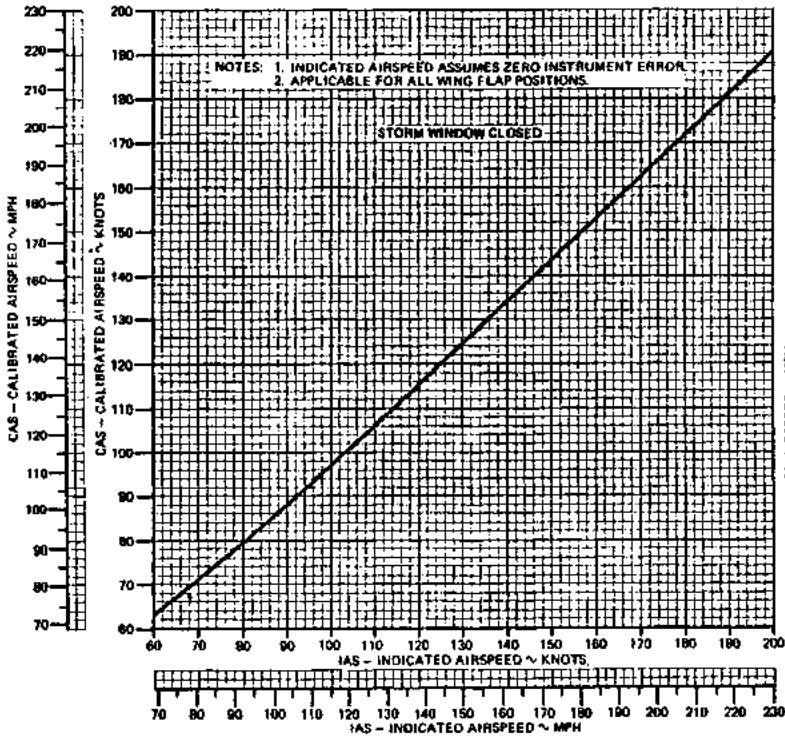

EXAMPLE:

IAS . . . . . 100 KTS (115 MPH)  
 STORM WINDOW . . . . . OPEN  
 CAS . . . . . 92 KTS (106 MPH)

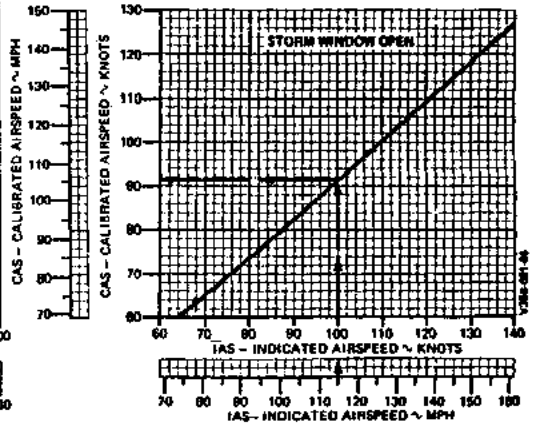

**ALTIMETER CORRECTION - EMERGENCY SYSTEM**

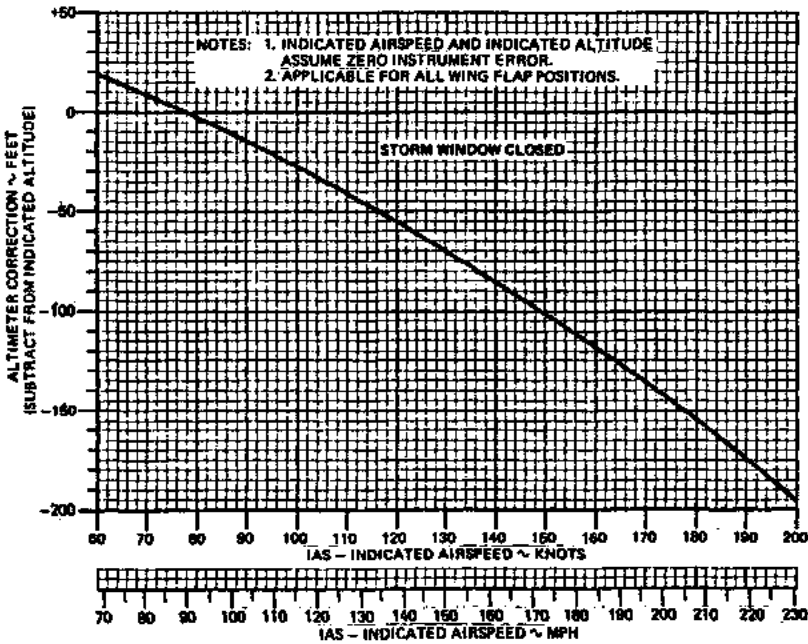

**EXAMPLE:**

IAS ..... 70 KTS (81 MPH)  
 STORM WINDOW ..... OPEN  
 INDICATED PRESSURE ALTITUDE ..... 5000 FT

---

ALTITUDE CORRECTION ..... -33 FT  
 ACTUAL PRESSURE ALTITUDE ..... 5000 - 33 = 4967 FT

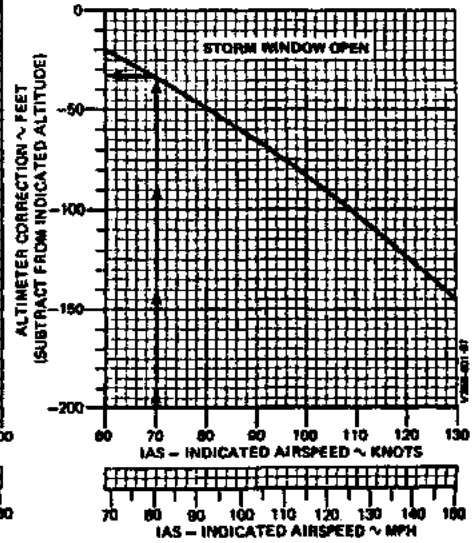

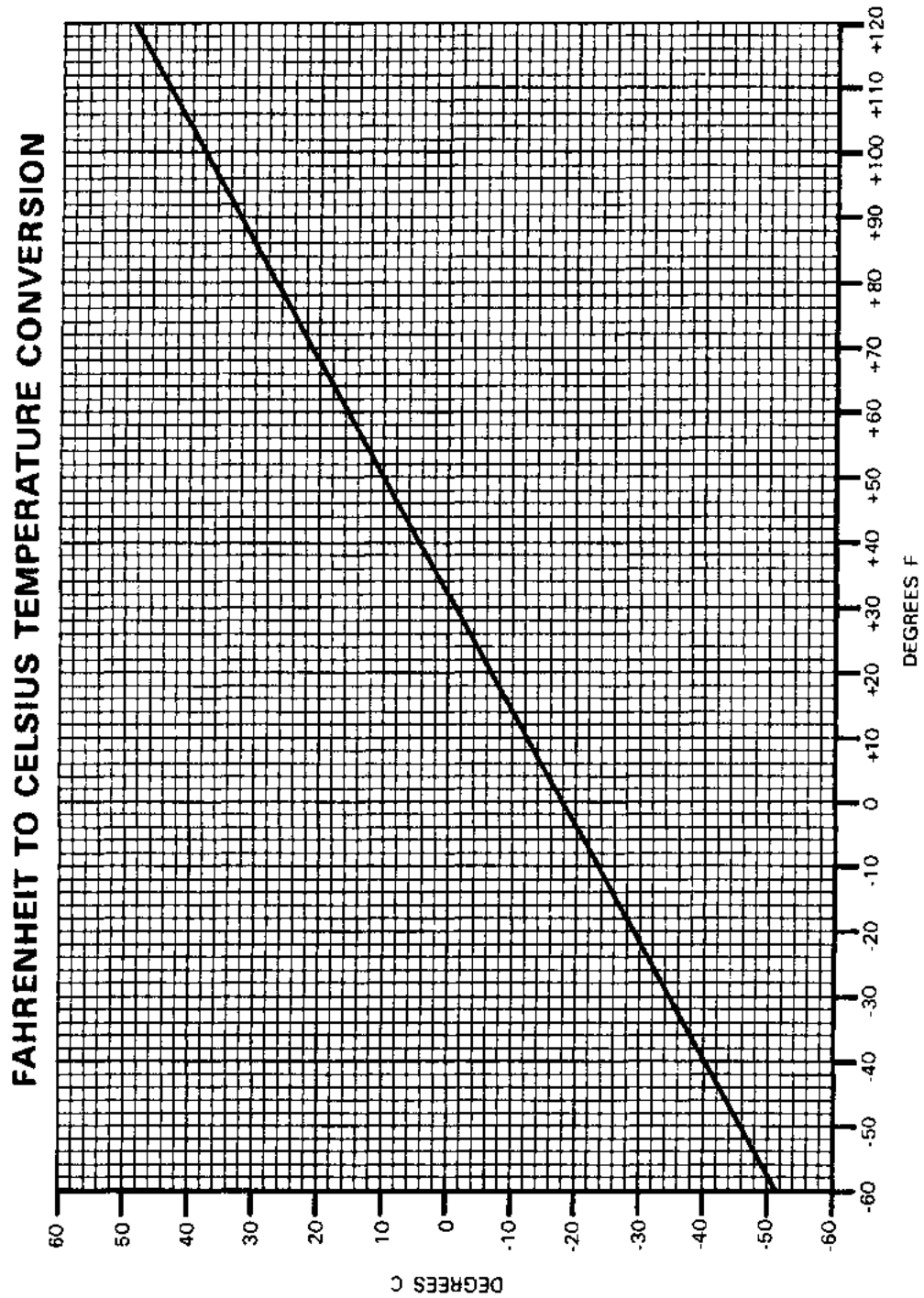

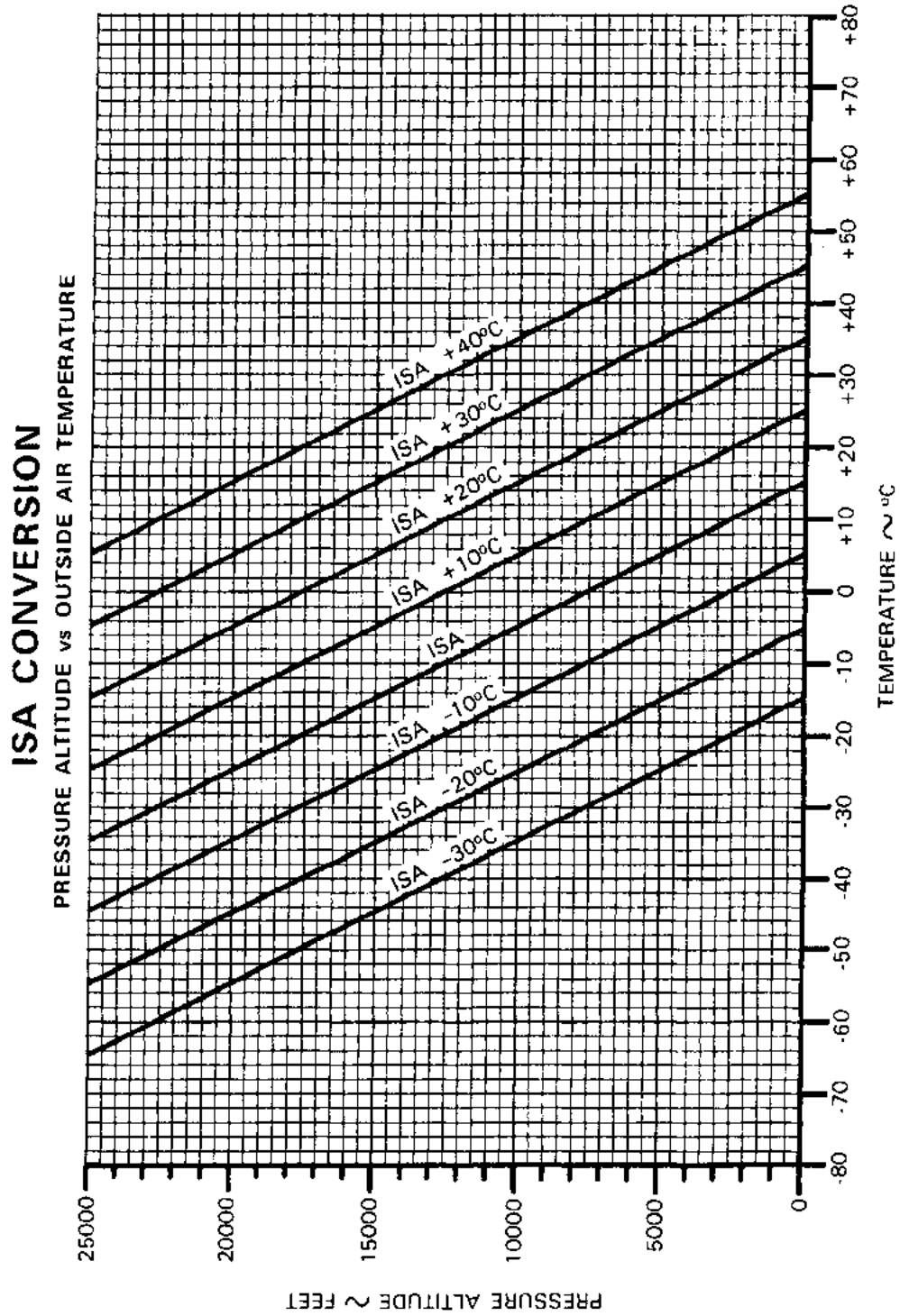

### STALL SPEEDS - POWER IDLE

- NOTES:** 1. THE MAXIMUM ALTITUDE LOSS EXPERIENCED WHILE CONDUCTING STALLS IN ACCORDANCE WITH CAM 3.120 WAS 200 FT.  
 2. A NORMAL STALL RECOVERY TECHNIQUE MAY BE USED

<b>EXAMPLE</b>	
WEIGHT	2800 LBS
FLAPS	UP
ANGLE OF BANK	30°
STALL SPEED	CAS: 64 KNOTS (74 MPH)

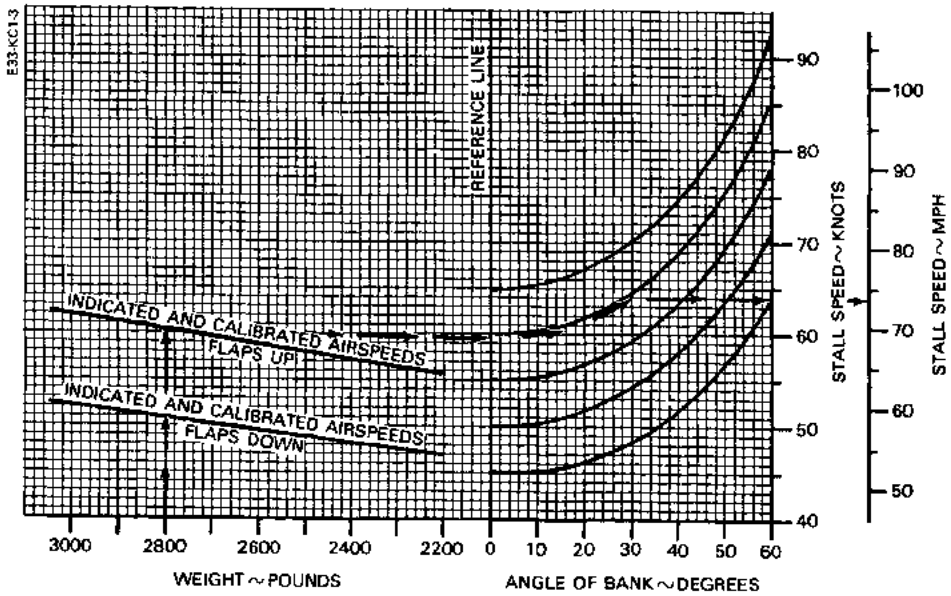

**WIND COMPONENTS**

**Demonstrated Crosswind Component is 17 kts**

**EXAMPLE:**

WIND SPEED	20 KTS
ANGLE BETWEEN WIND DIRECTION AND FLIGHT PATH	50°
HEADWIND COMPONENT	13 KTS
CROSSWIND COMPONENT	15 KTS

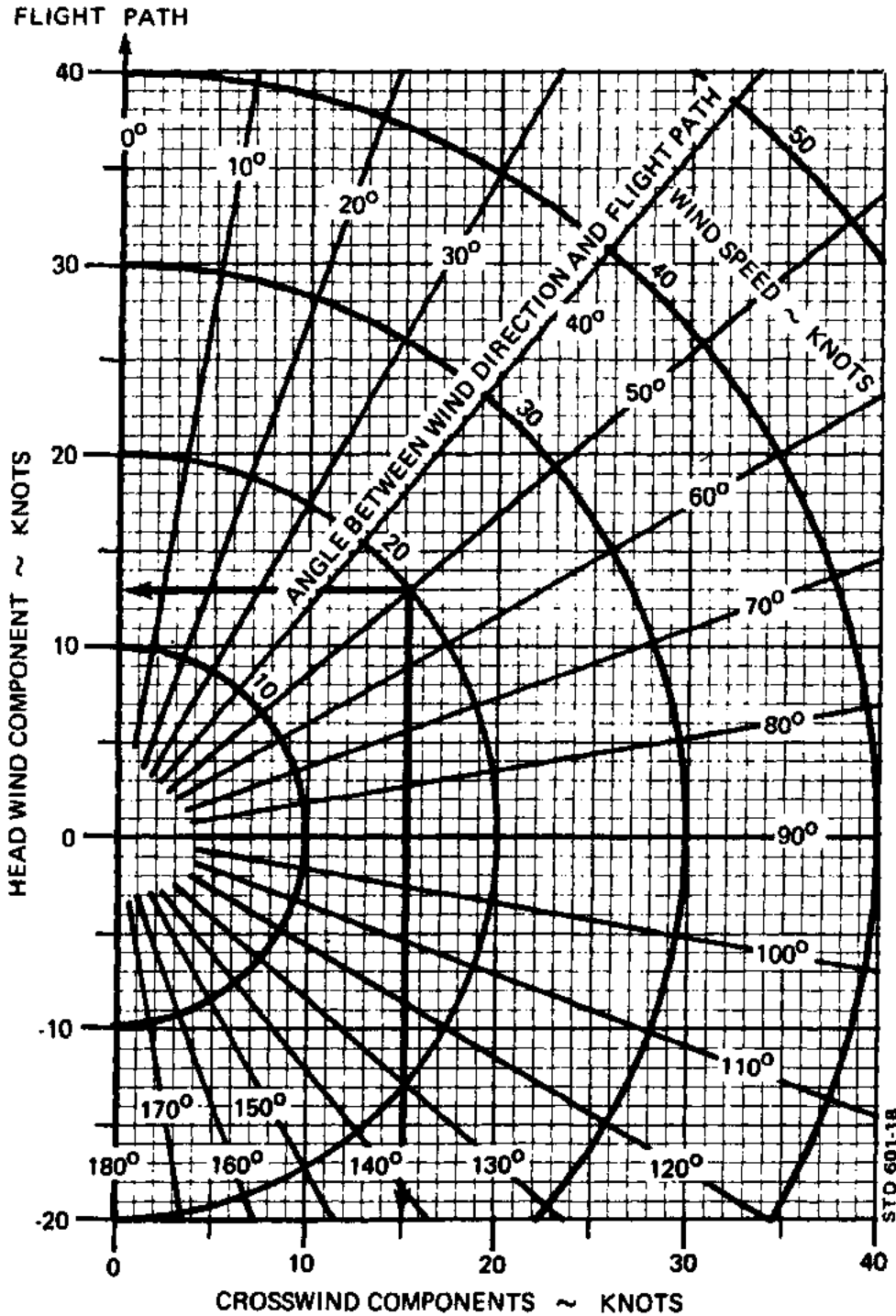

5-18

**ASSOCIATED CONDITIONS:**

POWER FULL THROTTLE  
2600 RPM  
MIXTURE LEAN TO APPROPRIATE  
FUEL FLOW  
FLAPS UP  
LANDING GEAR RETRACT AFTER POSITIVE  
CLIMB ESTABLISHED  
COWL FLAPS OPEN

**TAKE-OFF DISTANCE**

WEIGHT ~ POUNDS	TAKE-OFF SPEED			
	LIFT-OFF		50 FT	
	KNOTS	MPH	KNOTS	MPH
3050	68	78	74	85
2900	67	77	73	84
2700	65	75	71	82
2400	62	71	68	78

**EXAMPLE:**

OAT 15°C (59°F)  
PRESSURE ALTITUDE 5650 FT  
TAKE-OFF WEIGHT 3050 LBS  
HEAD WIND COMP. 9.5 KNOTS

---

GROUND ROLL 2000 FT  
TOTAL DISTANCE OVER  
A 50 FT OBSTACLE 3150 FT  
TAKE-OFF SPEED AT  
LIFT-OFF 68 KNOTS (78 MPH)  
50 FT 74 KNOTS (85 MPH)

E33-KC1-4

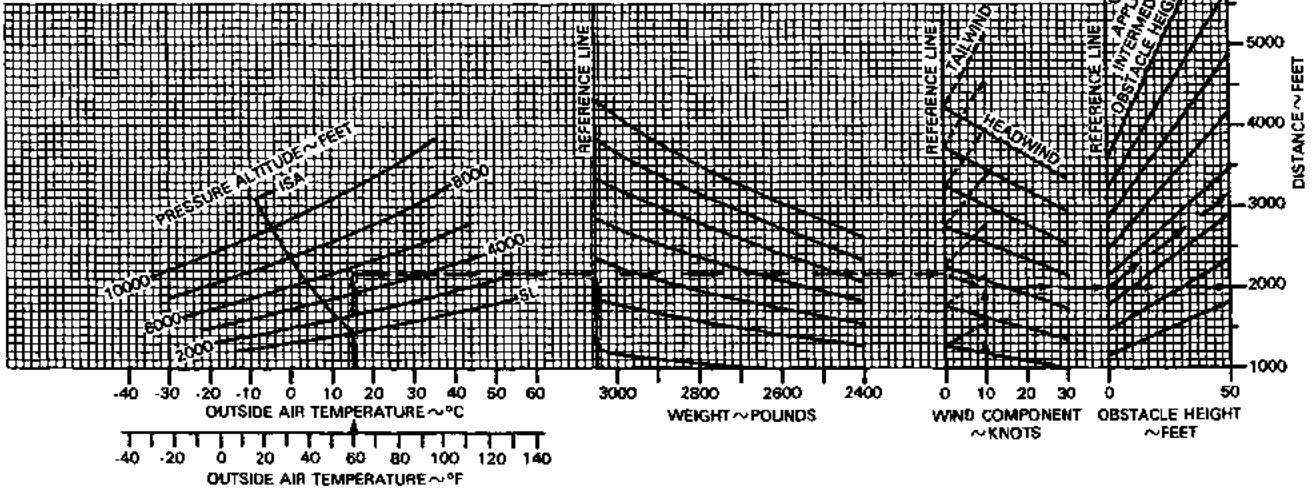

August 1982

Section V  
Performance

BEECHCRAFT  
Debonair C33  
Bonanza E33 and F33

**BEECHCRAFT**  
**Debonair C33**  
**Bonanza E33 and F33**

**Section V**  
**Performance**

**CLIMB**

**ASSOCIATED CONDITIONS:**  
 POWER FULL THROTTLE  
 AT 2600 RPM  
 MIXTURE LEAN TO APPROPRIATE  
 FUEL FLOW  
 FLAPS UP  
 LANDING GEAR UP  
 COWL FLAPS AS REQUIRED

CLIMB SPEED 90 KNOTS IAS (ALL WEIGHTS)  
 104 MPH IAS

**EXAMPLE:**

OAT -5°C (23°F)  
 PRESSURE ALTITUDE 11500 FT  
 WEIGHT 3035 LBS  
 RATE-OF-CLIMB 400 FT/MIN  
 CLIMB GRADIENT 3.8%  
 CLIMB SPEED 90 KNOTS (104 MPH)

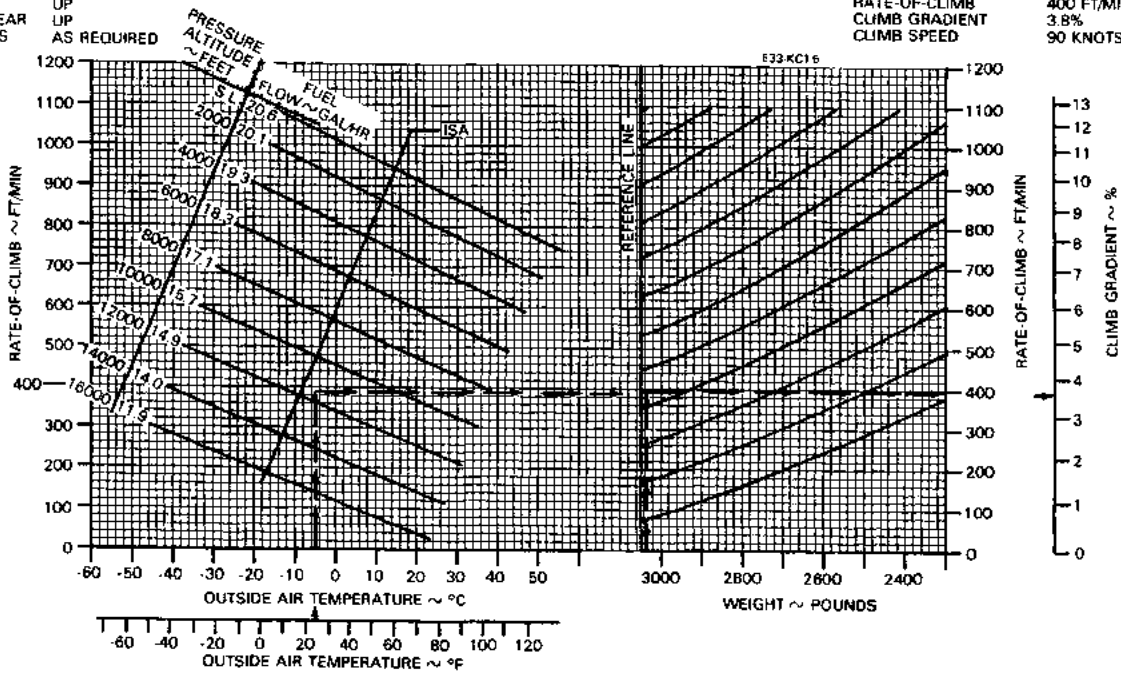

### TIME, FUEL AND DISTANCE TO CLIMB

**ASSOCIATED CONDITIONS:**

POWER 25 IN. HG. OR FULL THROTTLE  
 2500 RPM  
 FUEL DENSITY 6.0 LB./GAL  
 MIXTURE LEAN TO APPROPRIATE FUEL FLOW  
 COWL FLAPS CLOSED

CLIMB SPEED - 104 KNOTS  
 120 MPH

**EXAMPLE:**

OAT AT TAKE-OFF 15°C (59°F)  
 OAT AT CRUISE -5°C (23°F)  
 AIRPORT PRESSURE ALTITUDE 5650 FT  
 CRUISE PRESSURE ALTITUDE 11500 FT  
 INITIAL CLIMB WEIGHT 3050 LBS  
 TIME TO CLIMB (23-9) 13 MIN  
 FUEL TO CLIMB (6.1 - 2.8) 3.5 GAL  
 DISTANCE TO CLIMB (42 - 17) 25 NM

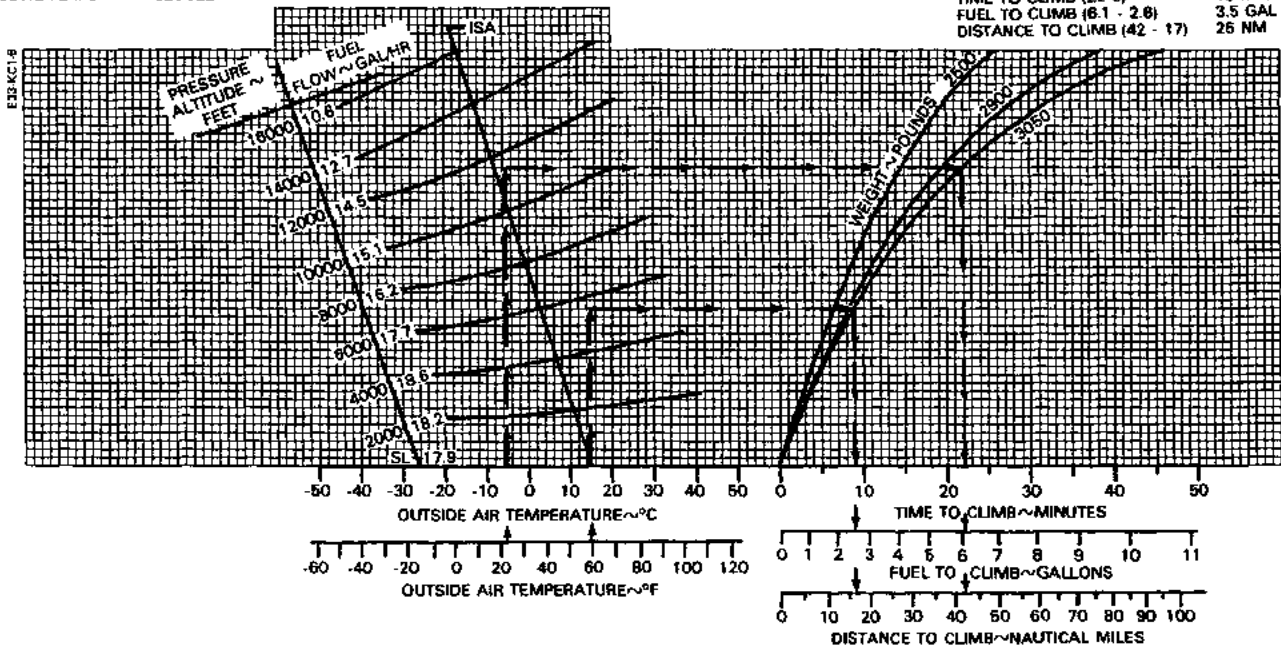

### CRUISE POWER SETTINGS

75% MAXIMUM CONTINUOUS POWER (OR FULL THROTTLE)  
@ AVERAGE CRUISE WEIGHT 2950 LBS.

PRESS ALT.	ISA -36°F (-20°C)								STANDARD DAY (ISA)								ISA +36°F (+20°C)										
	OAT		ENGINE SPEED	MAN. PRESS.		FUEL FLOW		TAS		OAT		ENGINE SPEED	MAN. PRESS.		FUEL FLOW		TAS		OAT		ENGINE SPEED	MAN. PRESS.		FUEL FLOW		TAS	
	FEET	°F	°C	RPM	IN HG	PSI	GPH	KTS	MPH	°F	°C	RPM	IN HG	PSI	GPH	KTS	MPH	°F	°C	RPM	IN HG	PSI	GPH	KTS	MPH		
SL	26	-3	2450	23.4	7.8	13.4	144	166	63	17	2450	24.0	7.8	13.4	148	170	99	37	2450	24.5	7.8	13.4	150	173			
2000	19	-7	2450	22.9	7.8	13.4	147	169	56	13	2450	23.4	7.8	13.4	150	173	92	33	2450	24.0	7.8	13.4	153	176			
4000	12	-11	2450	22.4	7.8	13.4	150	172	49	9	2450	22.8	7.8	13.4	153	176	85	29	2450	23.5	7.8	13.4	156	180			
6000	5	-15	2450	21.9	7.8	13.4	152	175	42	5	2450	22.2	7.8	13.4	156	179	76	26	2450	23.1	7.8	13.4	159	182			
8000	-2	-19	2450	21.3	7.8	13.4	156	178	35	1	2450	21.7	7.4	12.9	158	180	70	25	2450	21.7	6.8	12.1	165	178			
10000	6	-23	2450	20.3	7.3	12.7	155	178	27	-2	2450	20.1	6.5	12.0	154	177	63	17	2450	20.3	6.1	11.2	162	175			
12000	13	-27	2450	18.8	6.6	11.8	152	175	20	-7	2450	18.8	6.0	11.1	153	173	56	13	2450	18.8	5.6	10.5	148	171			
14000	21	-31	2450	17.3	5.8	10.9	149	171	11	-11	2450	17.3	5.5	10.3	146	168	49	6	2450	17.3	5.2	9.7	143	164			
16000	31	-26	2400	16.0	5.4	10.1	144	166	5	-16	2400	16.0	5.0	9.6	143	162	41	0	2450	16.0	4.8	9.1	139	166			

- NOTES:  
1. FULL THROTTLE MANIFOLD PRESSURE SETTINGS ARE APPROXIMATE.  
2. SHADED AREA REPRESENTS OPERATION WITH FULL THROTTLE.

### CRUISE POWER SETTINGS

65% MAXIMUM CONTINUOUS POWER (OR FULL THROTTLE)  
@ AVERAGE CRUISE WEIGHT 2950 LBS.

PRESS ALT.	ISA -36°F (-20°C)								STANDARD DAY (ISA)								ISA +36°F (+20°C)							
	OAT		ENGINE SPEED	MAN. PRESS	FUEL FLOW		TAS		OAT		ENGINE SPEED	MAN. PRESS	FUEL FLOW		TAS		OAT		ENGINE SPEED	MAN. PRESS	FUEL FLOW		TAS	
	FEET	°F	°C	RPM	IN HG	PSI	GPH	KTS	MPH	°F	°C	RPM	IN HG	PSI	GPH	KTS	MPH	°F	°C	RPM	IN HG	PSI	GPH	KTS
SL	26	-3	2450	21.2	6.3	11.5	135	156	63	17	2450	21.7	6.3	11.5	138	159	98	37	2450	22.3	6.3	11.5	141	163
2000	19	-7	2450	20.7	6.3	11.5	138	159	55	13	2450	21.3	6.3	11.5	141	162	91	33	2450	21.8	6.3	11.5	144	166
4000	12	-11	2450	20.3	6.3	11.5	140	162	48	9	2450	20.8	6.3	11.5	143	165	84	29	2450	21.4	6.3	11.5	146	168
6000	5	-15	2450	19.8	6.3	11.5	143	164	41	5	2450	20.4	6.3	11.5	146	168	77	25	2450	20.9	6.3	11.5	149	171
8000	-2	-19	2450	19.4	6.3	11.5	145	167	34	1	2450	19.9	6.3	11.5	148	171	70	21	2450	20.4	6.3	11.5	151	174
10000	-9	-23	2450	18.9	6.3	11.5	148	170	27	-3	2450	19.5	6.3	11.5	151	174	63	17	2450	20.0	6.3	11.5	152	175
12000	-16	-27	2450	18.5	6.3	11.5	150	171	20	-7	2450	19.5	6.3	11.5	151	174	56	10	2450	19.5	6.3	11.5	148	171
14000	-23	-31	2450	17.3	6.3	10.8	148	171	13	-11	2450	17.3	6.3	10.3	146	168	49	0	2450	17.3	6.3	9.7	153	164
16000	-31	-36	2450	16.0	6.3	10.1	144	166	6	-15	2450	16.0	6.3	8.8	141	163	41	5	2450	16.0	4.8	9.1	135	156

- NOTES:  
 1. FULL THROTTLE MANIFOLD PRESSURE SETTINGS ARE APPROXIMATE.  
 2. SHADED AREA REPRESENTS OPERATION WITH FULL THROTTLE.

### CRUISE POWER SETTINGS

55% MAXIMUM CONTINUOUS POWER (OR FULL THROTTLE)  
@ AVERAGE CRUISE WEIGHT 2950 LBS

PRESS ALT.	ISA -36°F (-20°C)								STANDARD DAY (ISA)								ISA +36°F (+20°C)										
	OAT		ENGINE SPEED	MAN. PRESS	FUEL FLOW			TAS		OAT		ENGINE SPEED	MAN. PRESS	FUEL FLOW			TAS		OAT		ENGINE SPEED	MAN. PRESS	FUEL FLOW			TAS	
	FEET	°F	°C	RPM	IN HG	PSI	GPH	KTS	MPH	°F	°C	RPM	IN HG	PSI	GPH	KTS	MPH	°F	°C	RPM	IN HG	PSI	GPH	KTS	MPH		
SL	26	-4	2300	20.2	5.2	9.8	126	145	62	17	2300	20.7	5.2	9.8	128	147	98	37	2300	21.1	5.2	9.8	130	150			
2000	19	-7	2300	19.7	5.2	9.8	128	147	55	13	2300	20.3	5.2	9.8	130	150	91	33	2300	20.7	5.2	9.8	133	153			
4000	12	-11	2300	19.2	5.2	9.8	130	149	48	9	2300	19.8	5.2	9.8	132	152	84	29	2300	20.2	5.2	9.8	135	155			
6000	4	-15	2300	18.7	5.2	9.8	132	152	41	5	2300	19.3	5.2	9.8	134	154	77	25	2300	19.8	5.2	9.8	136	157			
8000	-3	-19	2300	18.2	5.2	9.8	134	154	34	1	2300	18.8	5.2	9.8	136	157	70	21	2300	19.3	5.2	9.8	138	159			
10000	-10	-23	2300	17.8	5.2	9.8	136	156	27	-3	2300	18.3	5.2	9.8	138	159	63	17	2300	18.8	5.2	9.8	140	161			
12000	-17	-27	2300	17.3	5.2	9.8	138	158	19	-7	2300	17.9	5.2	9.8	140	161	55	13	2300	18.4	5.2	9.8	140	161			
14000	-24	-31	2300	16.8	5.2	9.8	140	161	12	-11	2300	17.3	5.2	9.8	136	156	48	8	2300	17.3	4.8	9.8	134	154			
16000	-31	-35	2300	16.2	4.8	8.2	136	150	5	-19	2300	16.2	4.7	8.2	132	152	41	5	2300	16.2	4.6	8.5	123	141			

NOTES:

1. FULL THROTTLE MANIFOLD PRESSURE SETTINGS ARE APPROXIMATE.
2. SHADED AREA REPRESENTS OPERATION WITH FULL THROTTLE.

### CRUISE POWER SETTINGS

45% MAXIMUM CONTINUOUS POWER (OR FULL THROTTLE)  
@ AVERAGE CRUISE WEIGHT 2950 LBS

PRESS ALT.	ISA -36°F (-20°C)								STANDARD DAY (ISA)								ISA +36°F (+20°C)							
	OAT		ENGINE SPEED	MAN. PRESS	FUEL FLOW		TAS		OAT		ENGINE SPEED	MAN. PRESS	FUEL FLOW		TAS		OAT		ENGINE SPEED	MAN. PRESS	FUEL FLOW		TAS	
	FEET	°F	°C	RPM	IN HG	PSI	GPH	KTS	MPH	°F	°C	RPM	IN HG	PSI	GPH	KTS	MPH	°F	°C	RPM	IN HG	PSI	GPH	KTS
SL	25	-4	2100	20.1	4.5	8.3	113	130	61	16	2100	20.4	4.5	8.3	115	132	97	36	2100	20.9	4.5	8.3	117	134
2000	18	-7	2100	19.6	4.5	8.3	115	132	54	12	2100	19.9	4.5	8.3	117	134	90	32	2100	20.5	4.5	8.3	118	136
4000	11	-12	2100	19.1	4.5	8.3	116	134	47	8	2100	19.5	4.5	8.3	118	136	83	28	2100	20.0	4.5	8.3	119	137
6000	4	-16	2100	18.6	4.5	8.3	118	135	40	4	2100	19.1	4.5	8.3	119	137	76	24	2100	19.5	4.5	8.3	120	138
8000	-3	-20	2100	18.2	4.5	8.3	119	137	33	-1	2100	18.7	4.5	8.3	120	138	69	21	2100	19.1	4.5	8.3	121	139
10000	-10	-24	2100	17.2	4.5	8.3	120	138	26	-3	2100	18.2	4.5	8.3	121	139	62	17	2100	18.6	4.5	8.3	121	139
12000	-17	-27	2100	17.3	4.5	8.3	120	139	19	-7	2100	17.8	4.5	8.3	121	139	55	13	2100	18.2	4.5	8.3	120	138
14000	-25	-32	2100	16.8	4.5	8.3	121	139	11	-12	2100	17.3	4.5	8.3	118	136	48	7	2100	17.3	4.5	8.3	117	134
16000	-32	-36	2100	16.0	4.5	7.9	119	127	2	-17	2100	16.0	4.2	7.7	115	132	39	3	2100	16.0	4.1	7.5	113	130

NOTES:

1. FULL THROTTLE MANIFOLD PRESSURE SETTINGS ARE APPROXIMATE.
2. SHADED AREA REPRESENTS OPERATION WITH FULL THROTTLE.

**CRUISE SPEEDS**

**ASSOCIATED CONDITIONS:**

AVERAGE CRUISE WEIGHT 2950 LBS  
 TEMPERATURE STANDARD DAY (ISA)

**EXAMPLE:**

PRESSURE ALTITUDE 11500 FT  
 POWER SETTING FULL THROTTLE  
 2450 RPM

TRUE AIRSPEED 151 KNOTS

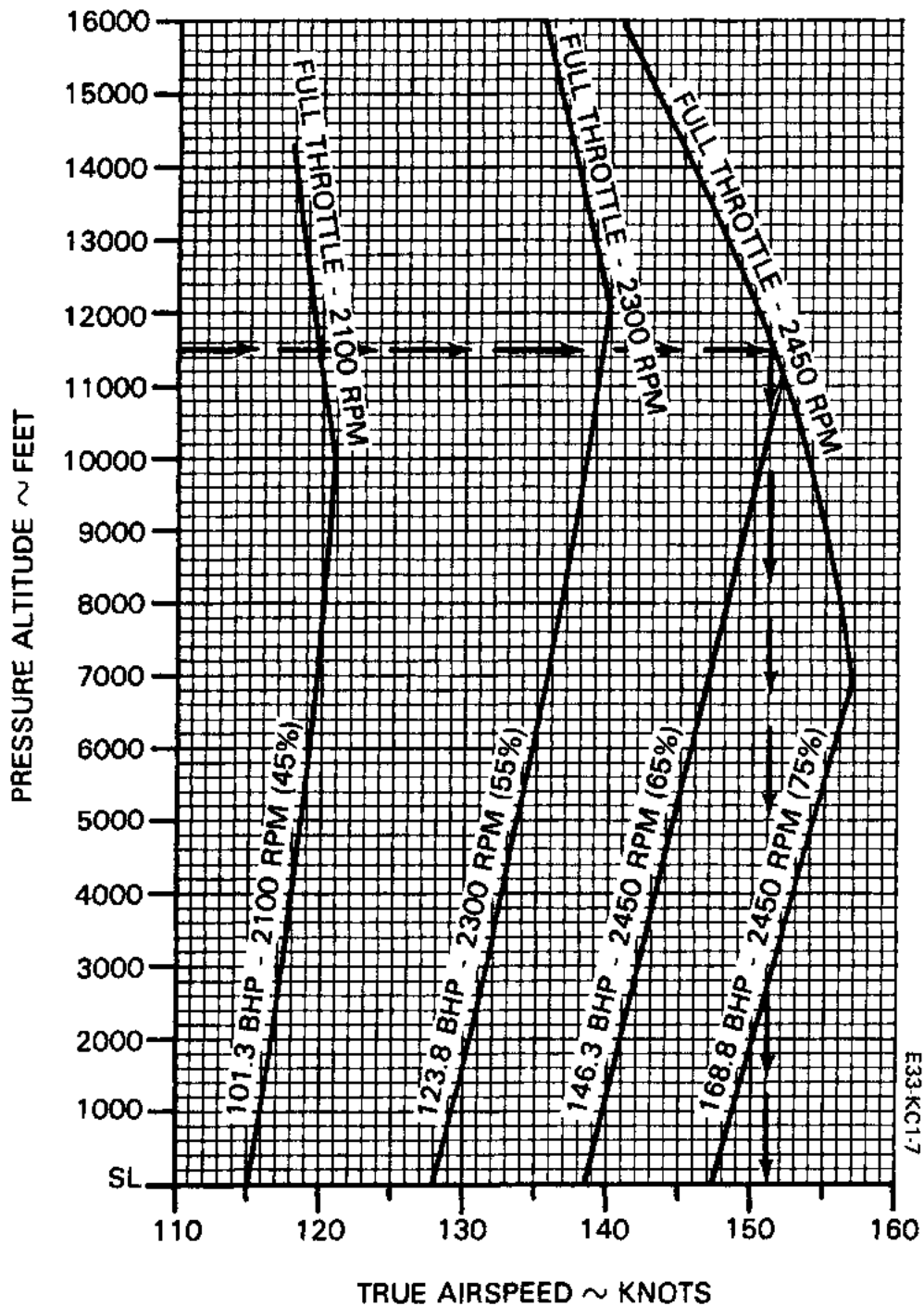

### MANIFOLD PRESSURE vs RPM

EXAMPLE:  
ENGINE SPEED 2450 RPM  
MANIFOLD PRESSURE 18.9 IN. HG.  
WITHIN RECOMMENDED LIMITS

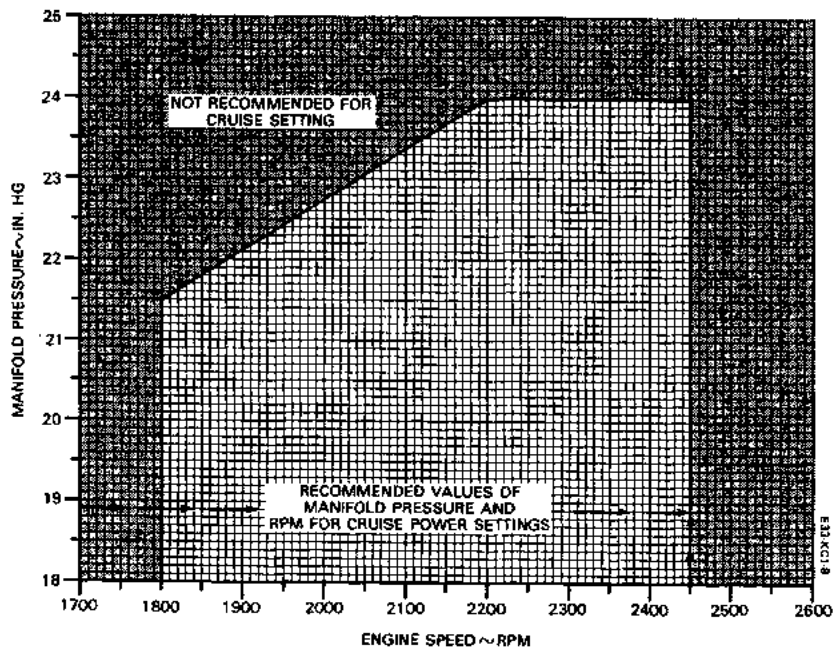

**FUEL FLOW vs BRAKE HORSEPOWER**

**EXAMPLE:**

① BRAKE HORSEPOWER	146.3
CONDITION	(85% MCP) LEVEL FLIGHT CRUISE LEAN
FUEL FLOW	11.4 GAL/HR
② FUEL FLOW	11.0 GAL/HR
CONDITION	LEVEL FLIGHT CRUISE LEAN
BRAKE HORSEPOWER	141

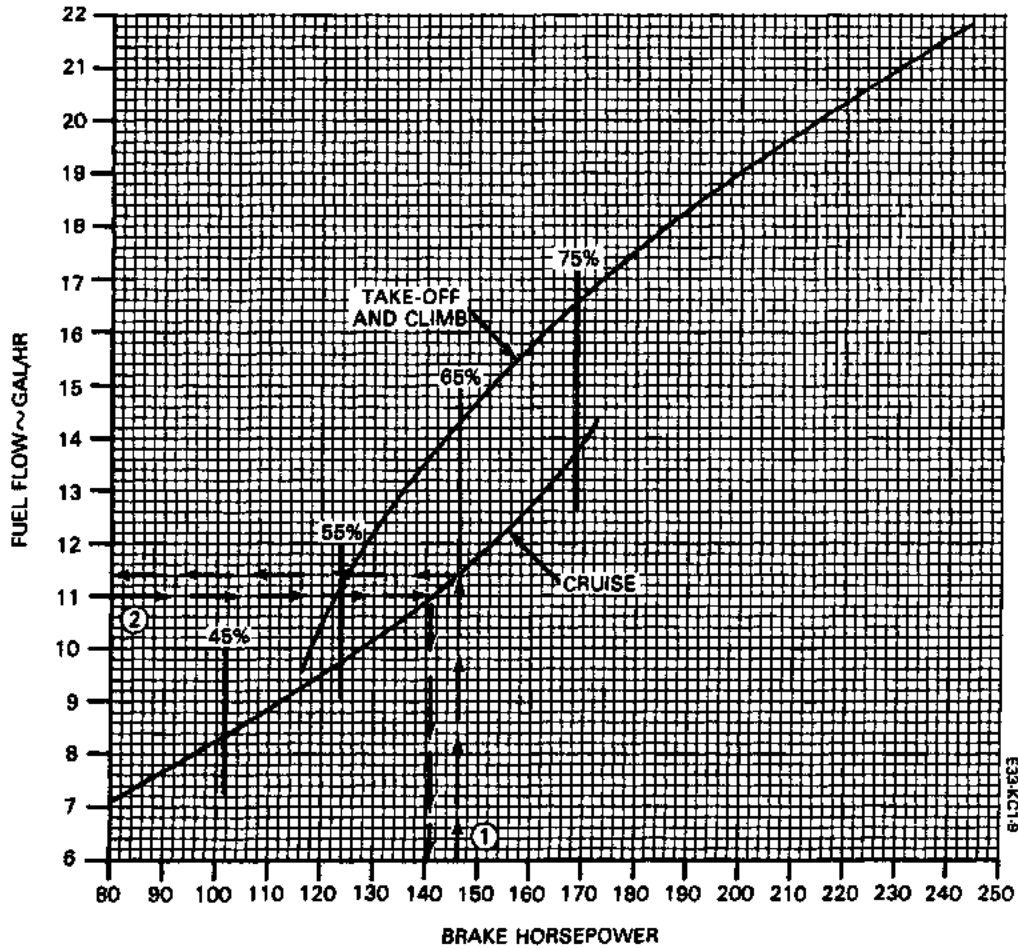

### RANGE PROFILE - 74 GALLONS

STANDARD DAY (ISA)

**ASSOCIATED CONDITIONS:**

WEIGHT 3060 LBS BEFORE ENGINE START  
 FUEL AVIATION GASOLINE  
 FUEL DENSITY 6.0 LBS/GAL  
 INITIAL FUEL LOADING 74 U.S. GAL (444 LBS)

**NOTE:**

RANGE INCLUDES START, TAXI, AND CLIMB WITH 45 MINUTES RESERVE FUEL AT 45% MCP

**EXAMPLE:**

PRESSURE ALTITUDE 11500 FT  
 POWER SETTING FULL THROTTLE 2450 RPM  
 RANGE 845 NM

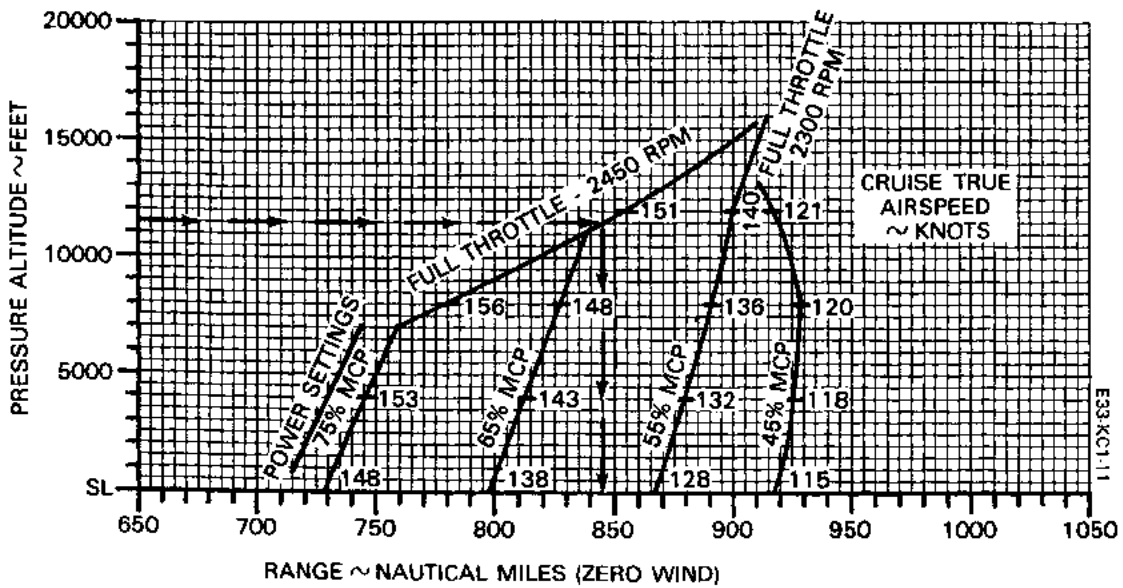

E33-KC1-11

**BEECHCRAFT**  
**Debonair C33**  
**Bonanza E33 and F33**

**Section V**  
**Performance**

**RANGE PROFILE - 44 GALLONS**

STANDARD DAY (ISA)

ASSOCIATED CONDITIONS:

WEIGHT 3060 LBS BEFORE ENGINE START  
 FUEL AVIATION GASOLINE  
 FUEL DENSITY 6.0 LBS/GAL  
 INITIAL FUEL LOADING 44 U.S. GAL (264 LBS)

NOTE:

RANGE INCLUDES START, TAXI AND CLIMB  
 WITH 45 MINUTES RESERVE FUEL AT 45% MCP

EXAMPLE:

PRESSURE ALTITUDE 11500 FT  
 POWER SETTING FULL THROTTLE 2450 RPM  
 RANGE 445 NM

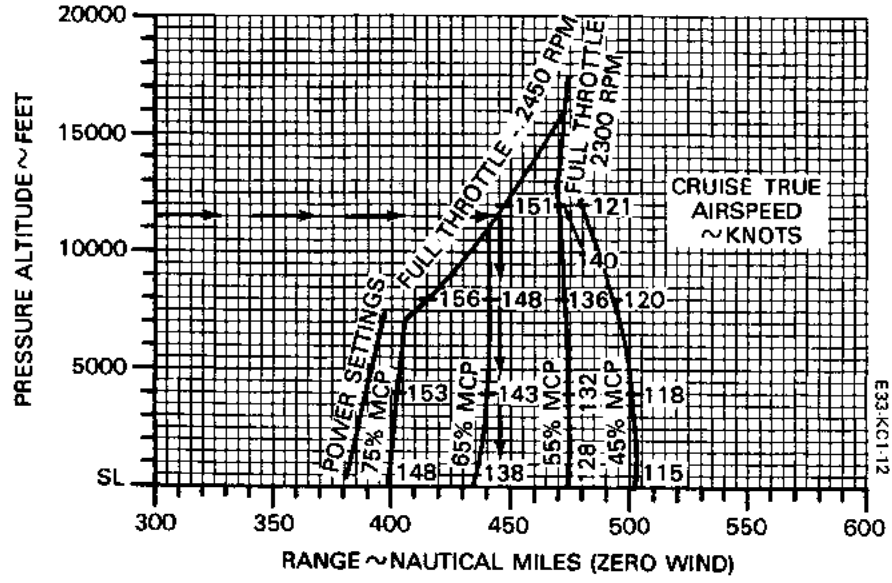

### ENDURANCE PROFILE - 74 GALLONS

ASSOCIATED CONDITIONS:

WEIGHT 3060 LBS BEFORE ENGINE START  
 FUEL AVIATION GASOLINE  
 FUEL DENSITY 6.0 LBS/GAL  
 INITIAL FUEL LOADING 74 U.S. GAL (444 LBS)

STANDARD DAY (ISA)

NOTE:  
 ENDURANCE INCLUDES START, TAXI, AND CLIMB  
 WITH 45 MINUTES RESERVE FUEL AT 45% MCP

EXAMPLE:

PRESSURE ALTITUDE 11500 FT  
 POWER SETTING FULL THROTTLE 2450 RPM  
 ENDURANCE 5.70 HRS  
 (5 HRS, 42 MIN)

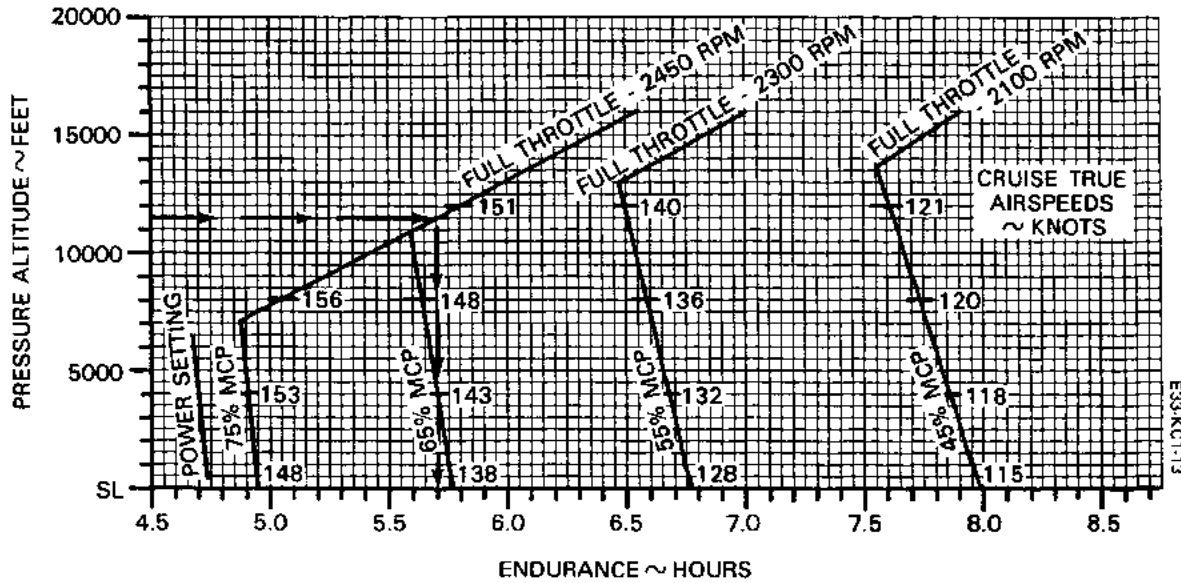

### ENDURANCE PROFILE - 44 GALLONS

STANDARD DAY (ISA)

**ASSOCIATED CONDITIONS:**

WEIGHT 3060 LBS BEFORE ENGINE START  
 FUEL AVIATION GASOLINE  
 FUEL DENSITY 6.0 LBS/GAL  
 INITIAL FUEL LOADING 44 U.S. GAL (264 LBS)

NOTE:  
 ENDURANCE INCLUDES START, TAXI, AND CLIMB  
 WITH 45 MINUTES RESERVE FUEL AT 45% MCP

**EXAMPLE:**

PRESSURE ALTITUDE 11500 FT  
 POWER SETTING FULL THROTTLE  
 2450 RPM  
 ENDURANCE 3.03 HRS  
 (3 HRS. 2 MIN)

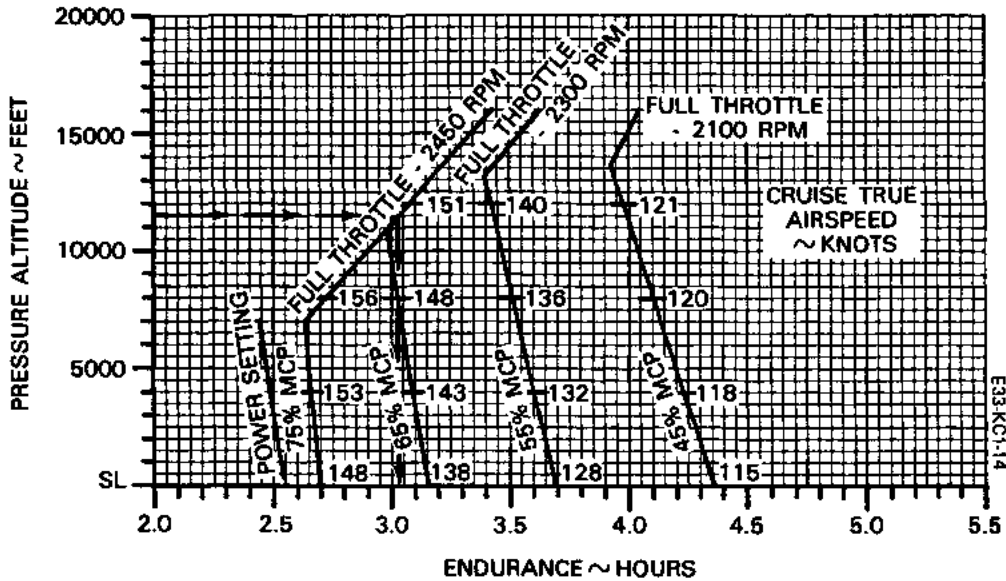

BEECHCRAFT  
 Debonair C33  
 Bonanza E33 and F33

Section V  
 Performance

**ASSOCIATED CONDITIONS:**

POWER RETARDED TO MAINTAIN 900 FT/MIN ON FINAL APPROACH  
 FLAPS DOWN  
 LANDING GEAR DOWN  
 RUNWAY PAVED, LEVEL, DRY SURFACE  
 APPROACH SPEED IAS AS TABULATED  
 BRAKING MAXIMUM

**LANDING DISTANCE**

WEIGHT ~ POUNDS	SPEED AT 50 FT	
	KNOTS	MPH
3060	70	81
3000	69	79
2800	67	77
2600	65	75
2400	64	73

**EXAMPLE**

OAT 25°C (77°F)  
 PRESSURE ALTITUDE 3965 FT  
 WEIGHT 2884 LBS  
 WIND COMPONENT 9.0 KNOTS (HEADWIND)  
 GROUND ROLL 1150 FT  
 TOTAL OVER 50 FT OBSTACLE 1275 FT  
 APPROACH SPEED 68 KNOTS (78 MPH)

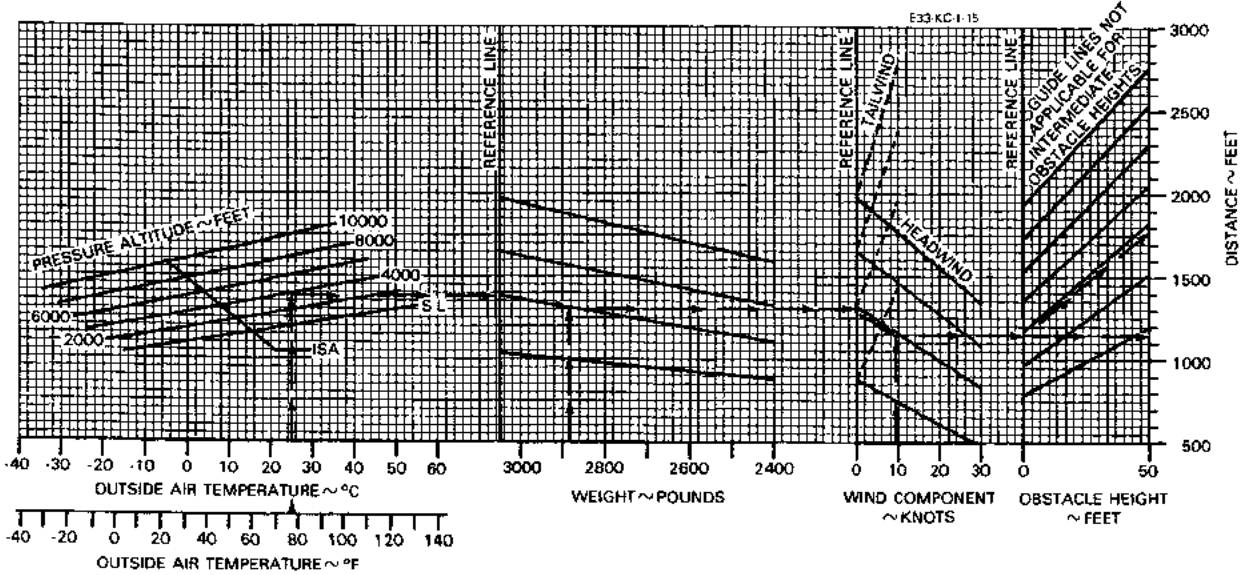

**BEECHCRAFT**  
**Debonair C33**  
**Bonanza E33 and F33**

# **SECTION VI**

## **WEIGHT AND BALANCE/ EQUIPMENT LIST**

### **TABLE OF CONTENTS**

<i>SUBJECT</i>	<i>PAGE</i>
Weighing Instructions .....	6-3
Basic Empty Weight and Balance Form .....	6-6
Weight and Balance Record .....	6-7
Loading Instructions .....	6-9
Seating, Baggage and Equipment	
Arrangements .....	6-10
Gross Weight Moment Limits .....	6-11
Moment Limits vs Weight Table .....	6-12
Computing Procedure .....	6-15
Sample Weight and Balance Loading Form ...	6-17
Weight and Balance Loading Form .....	6-18
Useful Load Weights and Moments .....	6-19
Occupants .....	6-19
Baggage .....	6-20
Cargo .....	6-20
Usable Fuel .....	6-21
Oil .....	6-21
Equipment List .....	Provided for each airplane

**Section VI  
Wt and Bal/Equip List**

**BEECHCRAFT  
Debonair C33  
Bonanza E33 and F33**

**INTENTIONALLY LEFT BLANK**

## **WEIGHING INSTRUCTIONS**

Periodic weighing of the airplane may be required to keep the Basic Empty Weight current. All changes to the airplane affecting weight and balance are the responsibility of the airplane's operator.

1. Three jack points are provided for weighing: two on the wing front spar at Fuselage Station 83.1 and one on the aft fuselage at Fuselage Station 271.0.
2. Fuel should be drained preparatory to weighing. Tanks are drained from the regular drain ports with the airplane in static ground attitude. When tanks are drained, 1.5 pounds of undrainable fuel remain in the airplane at Fuselage Station 76.0. The remainder of the unusable fuel to be added to a drained system is 34.5 pounds at Fuselage Station 79.1.
3. Engine oil must be at the full level or completely drained. Total engine oil when full is 22 pounds at Fuselage Station 25.3. (Includes 3 pounds undrainable oil.)

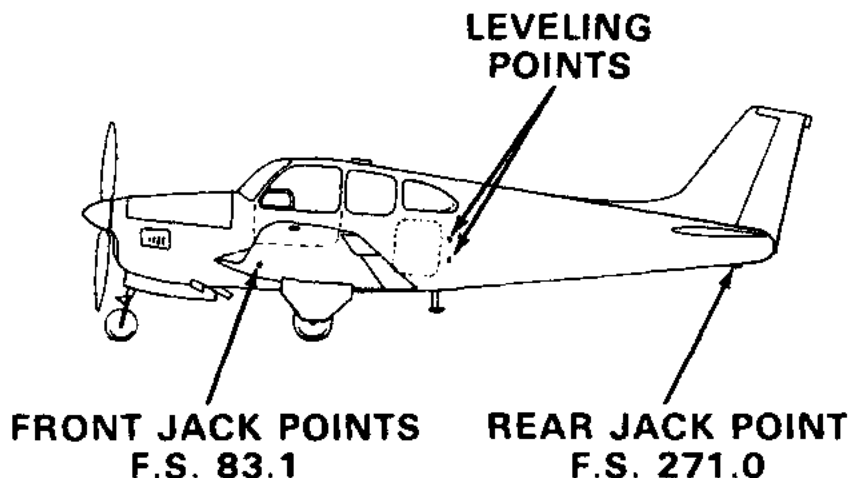

4. To determine airplane configuration at time of weighing, installed equipment is checked against the airplane equipment list or superseding forms. All installed equipment must be in its proper place during weighing.
5. At the time of weighing, the airplane must be level both longitudinally and laterally, and the landing gear must be fully extended. Leveling screws are located on the left side of the fuselage at approximately Fuselage Station 152.25. Longitudinally level attitude is determined with a plumb bob. Laterally level attitude is obtained when the vertical distance from each wing tip to the floor is equal.
6. Measurement of the reaction arms for a wheel weighing is made using a steel measuring tape. Measurements are taken, with the airplane level on the scales, from the reference (a plumb bob dropped from the center of either main jack point) to the axle center line of the main gear and then to the nose wheel axle center line. The main wheel axle center line is best located by stretching a string across from one main wheel to the other. All measurements are to be taken with the tape level with the hangar floor and parallel to the fuselage center line. The locations of the wheel reactions will be approximately at Fuselage Station 96.7 for main wheels and Fuselage Station 12.7 for the nose wheel.
7. Jack point weighings are accomplished by placing scales at the jack points specified in step 1 above. Since the center of gravity of the airplane is forward of Fuselage Station 83.1, the tail reaction of the airplane will be in an up direction. This can be measured on regular scales by placing ballast of approximately 200

pounds on the scales and attached to the aft weighing point by cable of adjustable length. The up reaction will then be total ballast weight minus the scale reading and is entered in the weighing form as a negative quantity.

8. Weighing should always be made in an enclosed area which is free from air currents. The scales used should be properly calibrated and certified.

#### **NOTE**

Each new airplane is delivered with a completed sample loading, empty weight and center of gravity, and equipment list, all pertinent to that specific airplane. It is the owner's responsibility to ensure that changes in equipment are reflected in a new weight and balance and in an addendum to the equipment list. There are many ways of doing this; it is suggested that a running tally of equipment changes and their effect on empty weight and c.g. is a suitable means for meeting both requirements.

The current equipment list and empty weight and c.g. information must be retained with the airplane when it changes ownership. Beech Aircraft Corporation cannot maintain this information; the current status is known only to the owner. If these papers become lost, the FAA will require that the airplane be reweighed to establish the empty weight and c.g. and that an inventory of installed equipment be conducted to create a new equipment list.

**BASIC EMPTY WEIGHT AND BALANCE**

6-6

DEBONAIR/  
 BONANZA SER. NO. \_\_\_\_\_ REG. NO. \_\_\_\_\_ DATE \_\_\_\_\_  
**STRUT POSITION - NOSE MAIN JACK POINT LOCATION PREPARED BY**  
 EXTENDED 11.8 96 FORWARD 83.1 Company \_\_\_\_\_  
 COMPRESSED 13.1 97 AFT 271.0 Signature \_\_\_\_\_

Section VI  
 Wt and Bal/Equip List

REACTION WHEEL - JACK POINTS	SCALE READING	TARE	NET WEIGHT	ARM	MOMENT
LEFT MAIN					
RIGHT MAIN					
NOSE OR TAIL					
TOTAL (AS WEIGHED)					
Space below provided for additions and subtractions to as weighed condition					
EMPTY WEIGHT (DRY)					
ENGINE OIL			22	-	557
UNUSABLE FUEL			36	79	2844
BASIC EMPTY WEIGHT					

BEECHCRAFT  
 Debonair C33  
 Bonanza E33 and F33

August 1982

BEECHCRAFT  
 Debonair C33  
 Bonanza E33 and F33

Section VI  
 Wt and Bal/Equip List

**WEIGHT AND BALANCE RECORD**

SERIAL NO. \_\_\_\_\_ REGISTRATION NO. \_\_\_\_\_ PAGE NO. \_\_\_\_\_

DATE	ITEM NO.		DESCRIPTION OF ARTICLE OR CHANGE	WEIGHT CHANGE ADDED (+) OR REMOVED (-)			RUNNING BASIC EMPTY WEIGHT	
	IN	OUT		WT (LBS)	ARM (IN.)	MOM 100	WT (LBS)	MOM 100

August 1982

6-7



## **LOADING INSTRUCTIONS**

It is the responsibility of the airplane operator to ensure that the airplane is properly loaded. At the time of delivery, Beech Aircraft Corporation provides the necessary weight and balance data to compute individual loadings. All subsequent changes in airplane weight and balance are the responsibility of the airplane owner and/or operator.

The empty weight and moment of the airplane at the time of delivery are shown on the airplane Empty Weight and Balance form. Useful load items which may be loaded into the airplane are shown on the Useful Load Weight and Moment tables. The minimum and maximum moments are indicated on the Moment Limits vs Weight table. These moments correspond to the forward and aft center of gravity flight limits for a particular weight. All moments are divided by 100 to simplify computations.

**SEATING, BAGGAGE AND EQUIPMENT  
ARRANGEMENTS**

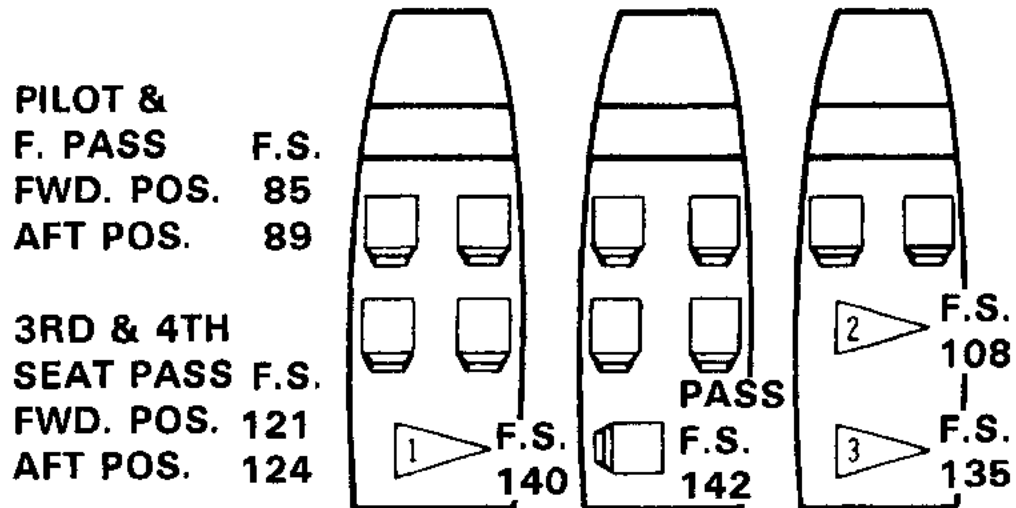

1. MAXIMUM WEIGHT 270 POUNDS INCLUDING EQUIPMENT AND BAGGAGE OR 5th SEAT AND PASSENGER.
2. MAXIMUM WEIGHT 200 POUNDS FORWARD OF REAR SPAR INCLUDING EQUIPMENT AND CARGO WITH 3rd AND 4th SEATS REMOVED.
3. MAXIMUM WEIGHT 270 POUNDS AFT OF REAR SPAR INCLUDING EQUIPMENT AND CARGO WITH 3rd, 4th AND 5th SEATS REMOVED.

**NOTE**

The floor structure load limit is 100 pounds per square foot, except for the area between the front and rear spars, where the floor structure load limit is 50 pounds per square foot.

**NOTE**

All baggage/cargo must be secured with an approved cargo net.

**GROSS WEIGHT MOMENT LIMITS**

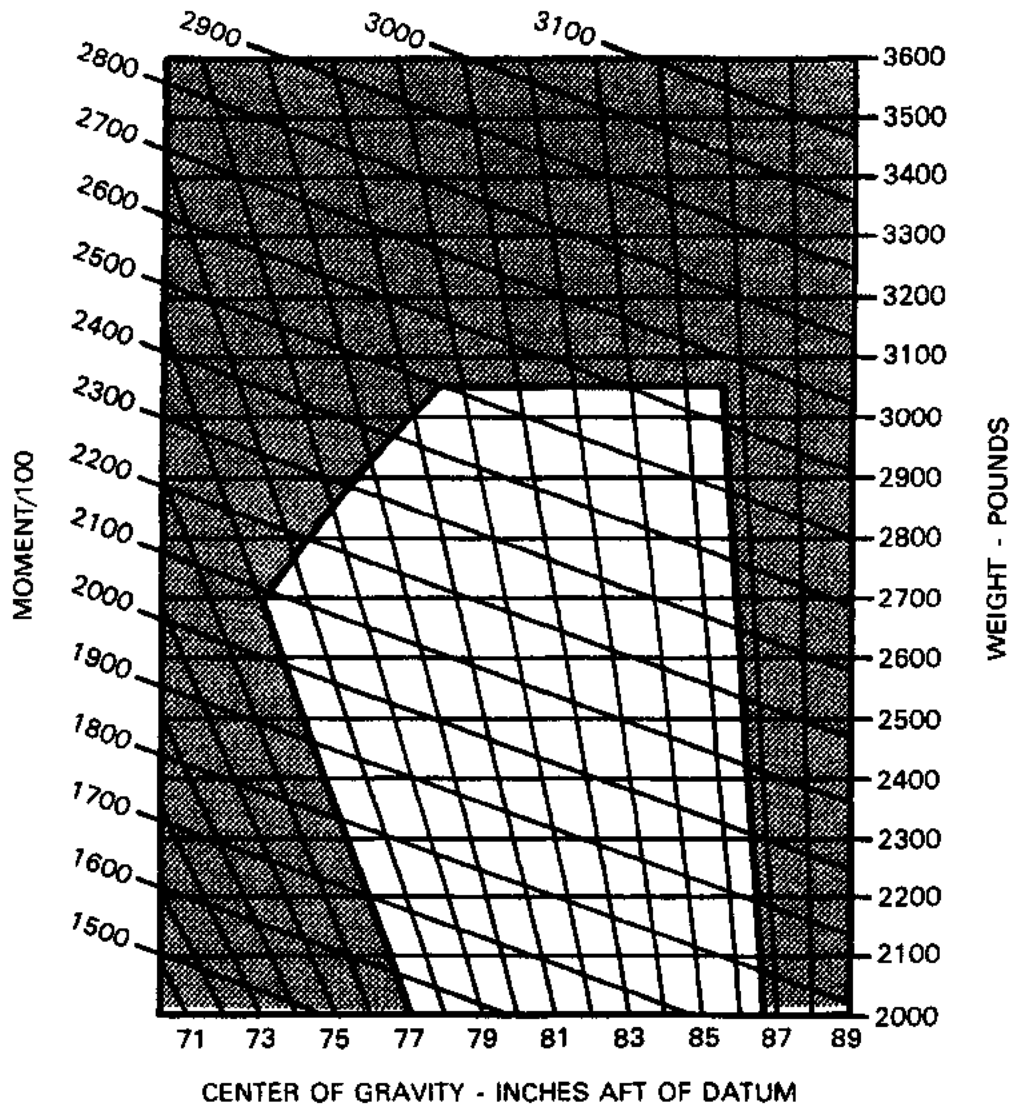

**MOMENT LIMITS vs WEIGHT**

Moment limits are based on the following weight and center of gravity limit data (landing gear down).

<b>WEIGHT CONDITION</b>	<b>FORWARD CG LIMIT</b>	<b>AFT CG LIMIT</b>
3050 lb. (take-off or landing)	81.5	86.7
2700 lb. or less	77.0	86.7
<b>Weight</b>	<b><u>Minimum Moment</u> 100</b>	<b><u>Maximum Moment</u> 100</b>
2100	1617	1821
2110	1625	1829
2120	1632	1838
2130	1640	1847
2140	1648	1855
2150	1656	1864
2160	1663	1873
2170	1671	1881
2180	1679	1890
2190	1686	1899
2200	1694	1907
2210	1702	1916
2220	1709	1925
2230	1717	1933
2240	1725	1942
2250	1732	1951
2260	1740	1959
2270	1748	1968
2280	1756	1977
2290	1763	1985

**MOMENT LIMITS vs WEIGHT (Continued)**

<b>Weight</b>	<b>Minimum Moment 100</b>	<b>Maximum Moment 100</b>
2300	1771	1994
2310	1779	2003
2320	1786	2011
2330	1794	2020
2340	1802	2029
2350	1810	2037
2360	1817	2046
2370	1825	2055
2380	1833	2063
2390	1840	2072
2400	1848	2081
2410	1856	2089
2420	1863	2098
2430	1871	2107
2440	1879	2115
2450	1886	2124
2460	1894	2133
2470	1902	2141
2480	1910	2150
2490	1917	2159
2500	1925	2168
2510	1933	2176
2520	1940	2185
2530	1948	2194
2540	1956	2202
2550	1964	2211
2560	1971	2220
2570	1979	2228
2580	1987	2237
2590	1994	2246

**MOMENT LIMITS vs WEIGHT (Continued)**

<b>Weight</b>	<b>Minimum Moment 100</b>	<b>Maximum Moment 100</b>
2600	2002	2254
2610	2010	2263
2620	2017	2272
2630	2025	2280
2640	2033	2289
2650	2040	2298
2660	2048	2306
2670	2056	2315
2680	2064	2324
2690	2071	2332
2700	2079	2341
2710	2090	2350
2720	2101	2358
2730	2113	2367
2740	2124	2376
2750	2135	2384
2760	2146	2393
2770	2158	2402
2780	2169	2410
2790	2181	2419
2800	2192	2428
2810	2203	2436
2820	2215	2445
2830	2226	2454
2840	2238	2462
2850	2249	2471
2860	2261	2480
2870	2273	2488
2880	2284	2497
2890	2296	2506

**MOMENT LIMITS vs WEIGHT (Continued)**

<b>Weight</b>	<b><u>Minimum Moment</u> 100</b>	<b><u>Maximum Moment</u> 100</b>
2900	2308	2514
2910	2319	2523
2920	2331	2532
2930	2343	2540
2940	2355	2549
2950	2366	2558
2960	2378	2566
2970	2390	2575
2980	2402	2584
2990	2414	2592
3000	2426	2601
3010	2438	2610
3020	2450	2618
3030	2462	2627
3040	2474	2636
3050	2486	2644

**COMPUTING PROCEDURE**

1. Record the \*Basic Empty Weight and Moment from the Basic Empty Weight and Balance form (or from the latest superseding form) under the Basic Empty Condition block. The moment must be divided by 100 to correspond to Useful Load Weights and Moments tables.

2. Record the weight and corresponding moment from the appropriate table of each of the useful load items (except fuel) to be carried in the airplane.
3. Total the weight column and moment column. The SUB-TOTAL is the Zero Fuel Condition.
4. Determine the weight and corresponding moment for the fuel loading to be used. This fuel loading includes fuel for the flight, plus that required for start, taxi, and take-off. Add the Fuel to Zero Fuel Condition to obtain the SUB-TOTAL Ramp Condition.
5. Subtract the fuel to be used for start, taxi, and take-off to arrive at the SUB-TOTAL Take-off Condition.
6. Subtract the weight and moment of the fuel in the incremental sequence in which it is to be used from the take-off weight and moment. The Zero Fuel Condition, the Take-Off Condition, and the Landing Condition moment must be within the minimum and maximum moments shown on the Moment Limit vs Weight table for that weight. If the total moment is less than the minimum moment allowed, useful load items must be shifted aft or forward load items reduced. If the total moment is greater than the maximum moment allowed, useful load items must be shifted forward or aft load items reduced. If the quantity or location of load items is changed, the calculations must be revised and the moments rechecked.

The Empty Weight for the airplane may be converted to Basic Empty Weight by adding the weight and moment for full oil. (19 lbs. and 494 lb. in.)

**BEECHCRAFT  
Debonair C33  
Bonanza E33 and F33**

**Section VI  
Wt and Bal/Equip List**

The following Sample Loading chart is presented to depict the sample method of computing a load. Weights used DO NOT reflect an actual airplane loading.

**WEIGHT AND BALANCE LOADING FORM**

**DEBONAIR/  
BONANZA** \_\_\_\_\_ **DATE** \_\_\_\_\_

**SERIAL NO.** CD-XXX **REG NO.** NXXX

ITEM	WEIGHT	MOM/100
1. BASIC EMPTY CONDITION	2030	1612
2. FRONT SEAT OCCUPANTS	340	288
3. 3rd and 4th SEAT OCCUPANTS	340	412
4. 5th SEAT OCCUPANT	-	-
5. BAGGAGE	26	36
6. CARGO	-	-
7. SUB TOTAL ZERO FUEL CONDITION	2736	2348
8. FUEL LOADING (54 GAL)	324	243
9. SUB TOTAL RAMP CONDITION	3060	2591
10. *LESS FUEL FOR START, TAXI, AND TAKE-OFF	-10	-8
11. SUB TOTAL TAKE-OFF CONDITION	3050	2583
12. LESS FUEL TO DESTINATION (45 GAL)	-270	-202
13. LANDING CONDITION	2780	2381

\*Fuel for start, taxi and take-off is normally 10 lbs at an average mom/100 of 8.

Section VI  
Wt and Bal/Equip List

BEECHCRAFT  
Debonair C33  
Bonanza E33 and F33

WEIGHT AND BALANCE LOADING FORM

DEBONAIR/  
BONANZA \_\_\_\_\_ DATE \_\_\_\_\_

SERIAL NO. \_\_\_\_\_ REG NO. NXXX \_\_\_\_\_

ITEM	WEIGHT	MOM/100
1. BASIC EMPTY CONDITION		
2. FRONT SEAT OCCUPANTS		
3. 3rd and 4th SEAT OCCUPANTS		
4. 5th SEAT OCCUPANT		
5. BAGGAGE		
6. CARGO		
7. SUB TOTAL ZERO FUEL CONDITION		
8. FUEL LOADING		
9. SUB TOTAL RAMP CONDITION		
10. *LESS FUEL FOR START, TAXI, AND TAKE-OFF		
11. SUB TOTAL TAKE-OFF CONDITION		
12. LESS FUEL TO DESTINATION		
13. LANDING CONDITION		

\*Fuel for start, taxi and take-off is normally 10 lbs at an average mom/100 of 8.

**USEFUL LOAD WEIGHTS AND MOMENTS  
OCCUPANTS**

	Front Seats		Rear Seats (3rd and 4th)		Fifth Seat	
	Fwd Position	Aft Position	Fwd Position	Aft Position		
	ARM 85	ARM 89	ARM 121	ARM 124	ARM 142	
WEIGHT	MOM/100	MOM/100	MOM/100	MOM/100	WEIGHT	MOM/100
120	102	107	145	149	30	43
130	110	116	157	161	40	57
140	119	123	169	174	50	71
150	128	134	182	186	60	85
160	136	142	194	198	70	99
170	144	151	206	211	80	114
180	153	160	218	223	90	128
190	162	169	230	236	100	142
200	170	178	242	248	110	156
NOTE: OCCUPANT POSITIONS SHOWN ARE FOR THE SEATS ADJUSTED THE MAXIMUM RANGE. INTERMEDIATE POSITIONS WILL REQUIRE INTERPOLATION OF THE MOMENT/100 VALUES.					120	170
					130	185
					140	199
					150	213
					160	227
					170	241

August 1982

6-19

BEECHCRAFT  
Debonair C33  
Bonanza E33 and F33

Section VI  
Wt and Bal/Equip List

USEFUL LOAD WEIGHTS AND MOMENTS

BAGGAGE

CARGO

ARM 140		Fwd of Spar (3rd and 4th Seats Removed)	Aft of Spar (3rd, 4th and 5th Seats Removed)
		ARM 108	ARM 135
Weight	Mom/100	Mom/100	Mom/100
10	14	11	14
20	28	22	27
30	42	32	40
40	56	43	54
50	70	54	68
60	84	65	81
70	98	76	94
80	112	86	108
90	126	97	122
100	140	108	135
110	154	119	148
120	168	130	162
130	182	140	176
140	196	151	189
150	210	162	202
160	224	173	216
170	238	184	230
180	252	194	243
190	266	205	256
200	280	216	270
210	294		284
220	308		297
230	322		310
240	336		324
250	350		338
260	364		351
270	378		364

**USABLE FUEL**

<b>LEADING EDGE TANKS ARM 75</b>		
<b>Gallons</b>	<b>Weight</b>	<b><u>Moment</u> 100</b>
5	30	23
10	60	45
15	90	68
20	120	90
25	150	113
30	180	135
35	210	158
40	240	180
44	264	198
50	300	225
55	330	248
60	360	270
65	390	293
70	420	315
74	444	333

**\*OIL**

<b>Quarts</b>	<b>Weight</b>	<b><u>Moment</u> 100</b>
10	19	5

\*Included in Basic Empty Weight

**INTENTIONALLY LEFT BLANK**

# **SECTION VII**

## **SYSTEMS DESCRIPTION**

### **TABLE OF CONTENTS**

<i>SUBJECT</i>	<i>PAGE</i>
Airframe .....	7-5
Seating Arrangements .....	7-5
Flight Controls .....	7-5
Control Surfaces .....	7-5
Control Column .....	7-5
Rudder Pedals .....	7-6
Trim Controls .....	7-6
Electric Elevator Trim .....	7-6
Instrument Panel .....	7-7
Flight Instruments .....	7-7
Power Plant Instruments .....	7-7
Instrument Panel Schematic (C33, E33) .....	7-8
Instrument Panel Legend .....	7-9
Instrument Panel Schematic (F33) .....	7-10
Manifold Pressure and Fuel Flow Indicator .....	7-11
Multiple Readout Type Instrument .....	7-12
Avionics Panel .....	7-12
Switches .....	7-13
Ground Control .....	7-13
Wing Flaps .....	7-14
Landing Gear System .....	7-15
Control Switch .....	7-15
Position Indicators (C33, E33) .....	7-15
Position Indicators (F33) .....	7-16

**TABLE OF CONTENTS (Continued)**

<i>SUBJECT</i>	<i>PAGE</i>
Safety Switch .....	7-16
Circuit Breaker .....	7-16
Brakes .....	7-17
Manual Extension .....	7-17
Warning Horn .....	7-17
Baggage Compartment .....	7-18
Seat Adjustments .....	7-18
Doors, Windows and Exits .....	7-19
Cabin Door .....	7-19
Openable Cabin Windows .....	7-19
Emergency Exits .....	7-20
Control Column Lock Pin .....	7-20
Power Plant .....	7-21
Engine Controls .....	7-21
Throttle, Propeller, and Mixture .....	7-21
Cowling (F33) .....	7-21
Induction System Icing .....	7-22
Lubrication System .....	7-22
Starter .....	7-22
Propeller .....	7-23
Fuel System .....	7-24
Fuel Cells .....	7-24
Fuel System Schematic .....	7-25
Fuel Quantity Indication System .....	7-26
Auxiliary Fuel Pump .....	7-26
Fuel Tank Selection .....	7-26
Fuel Required for Flight .....	7-26
Electrical System .....	7-27
Battery .....	7-28
Generator .....	7-28
Alternator .....	7-28
External Power Receptacle .....	7-29

**TABLE OF CONTENTS (Continued)**

<i>SUBJECT</i>	<i>PAGE</i>
Lighting System .....	7-29
Interior Lighting .....	7-29
Exterior Lighting .....	7-30
Environmental System .....	7-31
Cabin Heating .....	7-31
Heating and Ventilation System Schematic (C33, E33) .....	7-32
Heating and Ventilation System Schematic (F33) .....	7-33
Heater and Defroster Operation .....	7-34
Cabin Ventilation .....	7-35
Cabin Fresh Air Outlets .....	7-35
Exhaust Vents .....	7-36
Oxygen System .....	7-36
Pitot and Static Systems .....	7-37
Pitot System .....	7-37
Pitot Heat .....	7-37
Normal Static Air System .....	7-37
Emergency Static Air System .....	7-38
Vacuum System .....	7-38
Instrument Pressure System .....	7-38
Stall Warning .....	7-39
Engine Break-in Information .....	7-39

**INTENTIONALLY LEFT BLANK**

## **AIRFRAME**

The BEECHCRAFT C33, E33 and F33 are all-metal, low-wing, single-engine airplanes with retractable tricycle landing gear and conventional horizontal and vertical stabilizers.

## **SEATING ARRANGEMENTS**

The C33 Debonair and the E33 and F33 Bonanzas are all 4- or 5-place airplanes. In the standard configuration 4 seats are installed. A 5th seat is optional.

## **FLIGHT CONTROLS**

### **CONTROL SURFACES**

Control surfaces are operated through push-pull rods and conventional cable systems terminating in bellcranks.

### **CONTROL COLUMN**

The throw-over type control column for elevator and aileron control can be placed in front of either front seat. Pull the T-handle latch at the back of the control arm and position the control wheel as desired. The aileron trimmer on the control column hub should be held until the column is repositioned. Check for full freedom of movement after repositioning the control.

The optional dual control column is required for flight instruction.

## **RUDDER PEDALS**

To adjust the rudder pedals, press the spring-loaded lever on each pedal arm and move the pedal forward or aft. The adjustment lever can also be used to place the right set of rudder pedals against the floor when not in use.

## **TRIM CONTROLS**

Elevator trim is controlled by a handwheel located to the left of the throttle. An elevator tab indicator dial is located above and to the left of the trim control handwheel.

The aileron trimmer on the control column hub displaces the ailerons; displacement is maintained by cable loads imposed by the trimmer.

### ***ELECTRIC ELEVATOR TRIM***

The optional electric elevator trim system controls include the ON-OFF switch located on the instrument panel, a thumb switch on the control wheel and a circuit breaker on the right subpanel. The ON-OFF switch must be in the ON position to operate the system. The thumb switch is moved forward for nose down, aft for nose up, and when released returns to the center OFF position. When the system is not being electrically actuated, the manual trim control wheel may be used.

## **INSTRUMENT PANEL**

The standard instrument panel of C33 and E33 models consists of the floating instrument panel on the upper left portion, the engine instrument cluster on the left sub-panel, a radio grouping to the right of the control wheel assembly and subpanels which provide a compact circuit breaker group across the base of the instrument panel.

The standard instrument panel of the F33 consists of the floating instrument panel on the upper left portion, the engine instruments on a surrounding fixed panel, a radio grouping to the right of the engine instruments, and a sub-panel which provides for a compact circuit breaker group on the right side and switching panel on the left.

## **FLIGHT INSTRUMENTS**

The floating instrument panel contains all flight instruments except the magnetic compass. On this panel are the airspeed indicator, gyro horizon, altimeter, turn coordinator, directional gyro, and vertical speed indicator, with provisions for an ADF indicator and a clock. Additional navigation equipment, such as dual omni indicators, can be mounted in the panel directly below the flight instrument grouping.

## **POWER PLANT INSTRUMENTS**

The engine instruments include: cylinder head temperature, oil temperature, oil pressure indicators, tachometer, manifold pressure, fuel flow, and fuel quantity indicators, and an ammeter.

C33, E33



Section VII  
Systems Description

BEECHCRAFT  
Debonair C33  
Bonanza E33 and F33

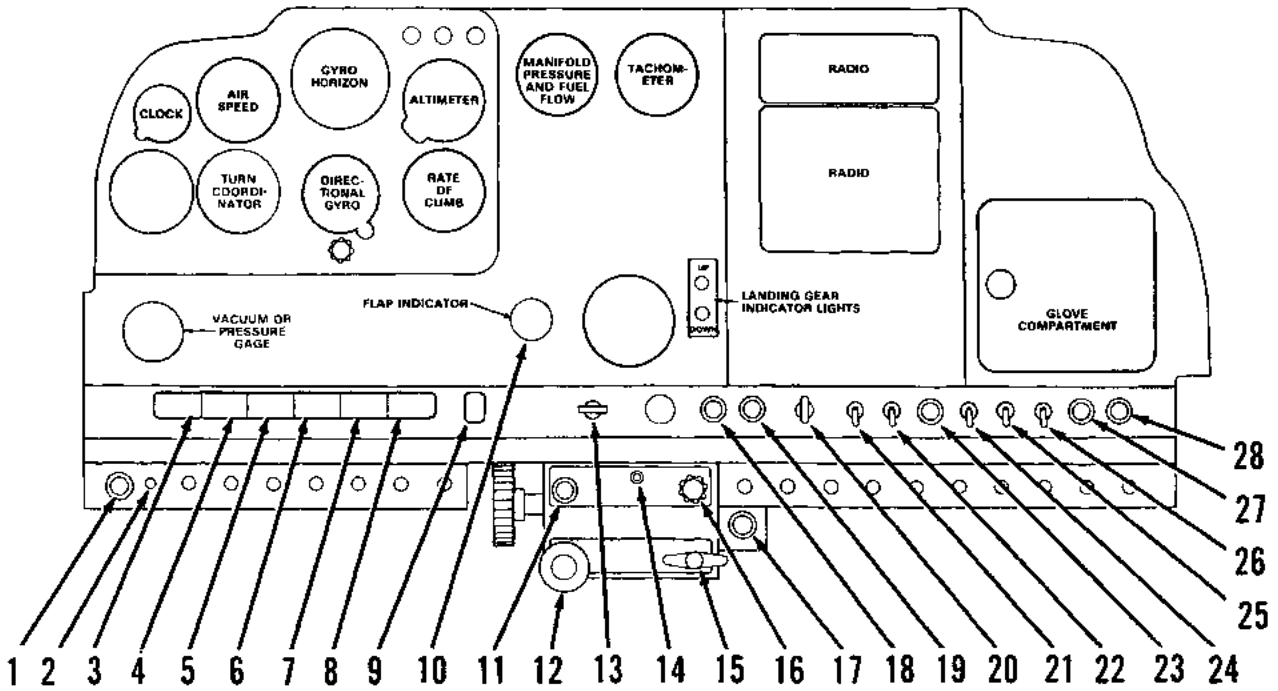

**INSTRUMENT PANEL LEGEND  
(TYPICAL)**

- |                                 |                                  |
|---------------------------------|----------------------------------|
| 1. Vent Shutoff Control         | 14. Auxiliary Fuel Pump Switch   |
| 2. Landing Gear Circuit Breaker | 15. Alternate Air Control        |
| 3. Left Fuel Gage               | 16. Propeller Control            |
| 4. Oil Pressure Gage            | 17. Aft Cabin Heat Control       |
| 5. Cylinder Head Temperature    | 18. Radio Lights Rheostat        |
| 6. Oil Temperature Gage         | 19. Instrument Panel Flood Light |
| 7. Ammeter                      | 20. Landing Gear Position Switch |
| 8. Right Fuel Gage              | 21. Lower Landing Light Switch   |
| 9. Elevator Tab Indicator       | 22. Upper Landing Light Switch   |
| 10. Flap Position Indicator     | 23. Parking Brake Control        |
| Lights - C33                    | 24. Rotating Beacon Switch       |
| Dial - E33                      | 25. Navigation Lights Switch     |
| 11. Throttle                    | 26. Pitot Heat Switch            |
| 12. Mixture Control             | 27. Cabin Heat Control           |
| 13. Flap Position Switch        | 28. Defrost Control              |

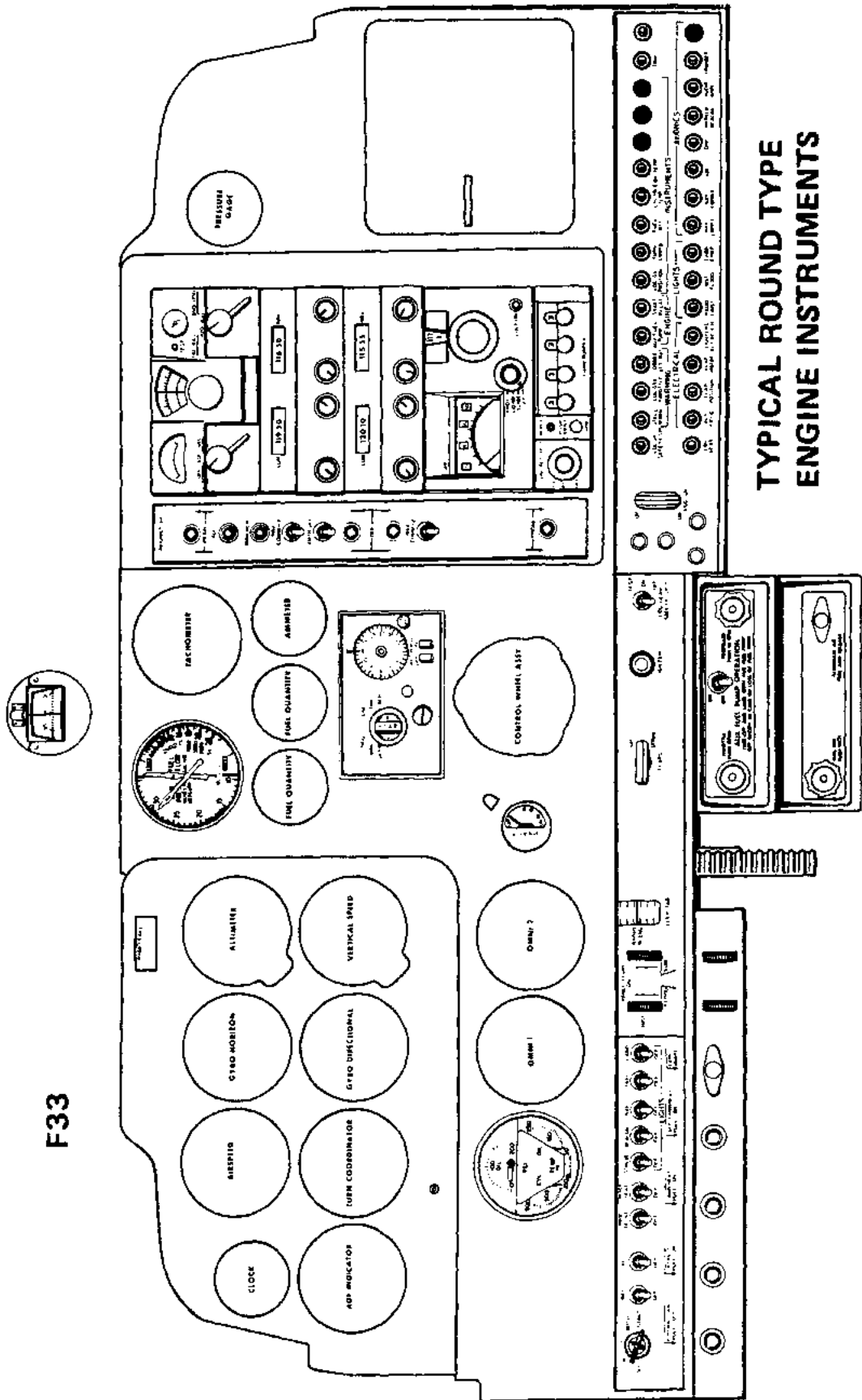

The cylinder head temperature sensor is installed in the engine cylinder which, because of location in the compartment, has the highest temperature reading. Monitor cylinder head temperature after power setting adjustments are made, to assure that the engine operating temperature remains in the desired range.

The oil pressure normal operating range is 30 to 60 psi. The oil pressure should be checked when starting the engine and with extra attention when starting during cold weather. The oil temperature operating range is 100°F to 240°F. Monitor the oil temperature after starting to assure temperature is above minimum before advancing the throttle above warm-up rpm and on descent with power reduced to avoid overcooling.

The tachometer is driven by a flexible shaft from the engine accessory section. Incorporated in the tachometer is an engine hour meter which automatically records the total engine operating time.

#### *MANIFOLD PRESSURE AND FUEL FLOW INDICATOR*

The manifold pressure portion of this instrument indicates the pressure of the fuel-air mixture entering the engine cylinders and is calibrated in inches of mercury. By observing the manifold pressure indications and adjusting the propeller and throttle controls, the power output of the engine can be regulated. To avoid excessive cylinder pressures during cruise operations, observe the maximum recommended rpm and manifold pressure as indicated on the Manifold Pressure vs RPM graph in the PERFORMANCE Section.

The fuel flow portion of the indicator is calibrated in gallons per hour, the green arc indicating fuel flow for normal operating limits. Red radials are placed at the minimum and maximum allowable fuel pressures.

In the cruise power range, the green sectors cover the fuel flow required from 45% to 75% power. The lowest value of a given sector is the cruise-lean setting, and the highest value of the sector is the best-power setting for that particular power range.

The take-off and climb range is covered by green sectors for full power at various altitudes. The high side of each green sector represents the fuel pressure setting required to achieve maximum power at the specified altitude when operating full throttle at 2600 rpm. These values should correspond to the fuel pressure values on the Climb graph in the PERFORMANCE Section.

#### *MULTIPLE READOUT TYPE INSTRUMENT (F33)*

The multiple readout type instrument is located on the lower left instrument panel and gives indications of cylinder head temperature calibrated in degrees Fahrenheit, oil temperature and oil pressure.

#### **AVIONICS PANEL**

Tuning and selecting equipment for the radios, to the right of the center panel, is mounted in block form with switching on the left edge of the block and radio heads and tuning on the right.

## **SWITCHES**

The battery master switch, generator (std.) or alternator (opt.) switch and key-operated magneto/start switch are grouped together at the left of the instrument panel. An escutcheon assembly contains the switches on C33 and E33 models; the F33 models have them located on the upper left subpanel.

The landing gear switch, the flap switch and the auxiliary fuel pump switch are located near the center console power plant controls. Interior and exterior lighting switches are located on either the right (C33, E33) or left (F33) subpanel.

## **GROUND CONTROL**

Steering is accomplished by use of the rudder pedals through a linkage arrangement which connects the nose strut to the rudder pedal shaft. Nose wheel straightening is accomplished by engagement of a roller with a track as the nose wheel is retracted. The steering link attaches to the steering mechanism on the nose strut with a swivel connection which permits the mechanism to disengage when the nose gear is retracted and operation of the rudder pedals will have no tendency to turn the nose wheel with the gear retracted.

The minimum wing tip turning radius, using full steering, one brake and partial power, is 26 feet 4 inches.

## **WING FLAPS**

### **C33**

The wing flaps are controlled by a three-position switch, UP, OFF, and DOWN, located in the subpanel, above the power quadrant. The switch must be pulled out of detent before it can be repositioned.

The flap position lights on the left side of the control console show green for the up position and red for the full-down landing position— intermediate 20-degree and 10-degree positions are indicated by lines painted on the leading edge of the left flap. The intermediate positions are reached when the marks are aligned with the trailing edge of the wing.

### **E33, F33**

The wing flaps are controlled by a three-position switch, UP, OFF, and DOWN, located in the subpanel, above the power quadrant. The switch must be pulled out of detent before it can be repositioned. A dial type indicator has markings for UP, 10°, 20°, and DN. The indicator is located to the left of the control column.

### **ALL MODELS**

Limit switches automatically turn off the electric motor when the flaps reach the extremes of travel. Intermediate flap positions can be obtained by placing the switch in the OFF position as the flaps reach the desired position during flap extension or retraction.

## **LANDING GEAR SYSTEM**

### *CAUTION*

Never taxi with a flat strut.

The landing gears are operated through adjustable linkage connected to an actuator assembly mounted beneath the front seats. The actuator assembly is driven by an electric motor. The landing gears may be electrically retracted and extended, and in an emergency may be extended manually.

### **CONTROL SWITCH**

The landing gear is controlled by a two-position switch on the right side of the subpanel. The switch handle must be pulled out of the safety detent before it can be moved to the opposite position.

### *CAUTION*

Do not change the position of the control switch to reverse the direction of the landing gear while the gear is in transit, as this could cause damage to the retract mechanism.

### **POSITION INDICATORS (C33, E33)**

Landing gear position indicator lights on the right side of the control console show red when the gear is up, or green when it is down, illuminating only when the actuator assembly reaches either extreme. In addition, a mechanical indicator on the floorboard beneath the control console shows the position of the nose gear. Its pointer is linked by a cable to the actuating mechanism and moves simultaneously with it. Limit switches and a dynamic brake automatically stop the retract mechanism when the gear reaches its full up or full down position.

### **POSITION INDICATORS (F33)**

The landing gear position indicator lights are located adjacent to the landing gear switch handle. Three green lights, one for each gear, are illuminated whenever the landing gear are down and locked. The red light illuminates any time one or all of the landing gear are in transit or in any intermediate position. All of the lights will be out when the gear are up.

Testing of the landing gear position indicator lights is accomplished by pressing the warning light test button on the floating instrument panel. The intensity of the lamps is automatically lowered for night flights when the navigation lights are turned on.

### **SAFETY SWITCH**

To prevent inadvertent retraction of the landing gear on the ground, a main strut safety switch opens the control circuit when the strut is compressed.

### **WARNING**

Never rely on the safety switch to keep the gear down during taxi or on take-off, landing roll, or in a static position. Always make certain that the landing gear switch is in the down position during these operations.

### **CIRCUIT BREAKER**

The landing gear circuit breaker is located on the (left - C33, E33) (right - F33) subpanel. This circuit breaker is a pull-and-reset type breaker. The breaker will pop out under overload conditions.

## **BRAKES**

The brakes on the main landing gear wheels are operated by applying toe pressure to the rudder pedals.

### *CAUTION*

Continuous brake application of either the pilot's or copilot's brake pedals in conjunction with an overriding pumping action from the opposite brake pedals could result in the loss of braking action on the side which continuous pressure is being applied.

The parking brake push-pull control is located on the sub-panel (right subpanel - C33, E33; left subpanel - F33). To set the parking brakes, depress both toe pedals until firm, then pull control out. Push the control in to release the brakes.

### *CAUTION*

The parking brake should be left off and wheel chocks installed if the airplane is to be left unattended. Changes in ambient temperature can cause the brakes to release or to exert excessive pressures.

## **MANUAL EXTENSION**

The landing gear can be manually extended by operating a handcrank at the rear of the front seats. This procedure is described in the EMERGENCY PROCEDURES section.

## **WARNING HORN**

With the landing gear retracted, if the throttle is retarded below approximately 12 in. Hg manifold pressure, a warning horn will sound intermittently.

## **BAGGAGE COMPARTMENT**

The baggage compartment is accessible through the baggage door on the right side of the fuselage. This area extends aft of the pilot and copilot seats to the rear bulkhead. Because of structural limitations, this area is divided into two sections, each having a different weight limitation. Loading within the baggage compartment must be in accordance with the data in the WEIGHT AND BALANCE Section. All baggage/cargo must be secured with an FAA approved restraint system.

### **WARNING**

Do not carry hazardous material anywhere in the airplane.

Do not carry children in the baggage compartment unless secured in a seat.

## **SEAT ADJUSTMENTS**

To adjust any of the four standard seats forward or aft, pull up on the release bar below the seat and slide the seat to the desired position. The seat backs of all standard seats can be placed in any of four positions by operating a release lever on the inboard side of each seat.

Outboard armrests for all standard seats are built into the cabin sidewalls. Center armrests can be elevated or positioned flush with the seat cushions. The optional fifth seat can be folded up to provide additional floor space.

## **DOORS, WINDOWS AND EXITS**

### **CABIN DOOR**

The outside cabin door handle is spring loaded to fit into a recess in the door to create a flat aerodynamically clean surface. To open the door from the outside, lift the handle from its recess and pull until the door opens.

To close the cabin door from the inside, observe that the door handle is in the unlocked position. In this position, the latch handle is free to move approximately one inch in either direction before engagement of the locking mechanism. Then grasp the door and firmly pull the door closed. Rotate the door handle fully counterclockwise into the locked position. When the door is properly locked, the door latch handle is free to move approximately one inch in either direction.

### **NOTE**

When checking the door latch handle, do not move it far enough to engage the door latch release mechanism.

Press firmly outward at the top rear corner of the door. If any movement of the door is detected, completely open the door and close again following the above instructions.

To open the door from the inside, depress the lock button and rotate the handle clockwise.

### **OPENABLE CABIN WINDOWS (Optional E33 and F33)**

To open window:

Release latch front of bar, pull bar at the bottom of the window out and upward. Window will open approximately two inches.

To close window:

Pull inward and down on the bar at the bottom of the window. Resistance will be felt as the bar moves downward. Continue moving bar downward to its lowest position. Check that bar is locked by the latch.

**NOTE**

Window is to be closed before and during flight. While closing window, ascertain that the emergency release pin (which allows the window to open fully for emergency exit) is securely in place.

**EMERGENCY EXITS (E33, F33 WITH OPTIONAL OPENABLE CABIN WINDOWS)**

To open the emergency exit provided by the openable middle window on each side of the cabin:

1. Lift the latch.
2. Pull out the emergency release pin and push the window out.

The above procedure is described on a placard installed below the left and right middle windows.

**CONTROL COLUMN LOCK PIN**

1. Rotate control wheel and move column so the hole in the bracket and the column align to accept pin.
2. Push the control column lock pin through the hole provided in the control column hanger and into the hole in the control column tube assembly.
3. Ensure positive retention of the lock pin by positioning the attached red plate on top of the throttle and propeller controls.

**WARNING**

Before starting engine, remove the lock reversing the above procedure.

## **POWER PLANT**

The BEECHCRAFT C33, E33, and F33 airplanes are all powered by a Continental IO-470-K, six-cylinder, wet sump, fuel-injection engine rated at 225 hp at 2600 rpm for take-off and maximum continuous operation.

## **ENGINE CONTROLS**

### ***THROTTLE, PROPELLER, AND MIXTURE***

The push-pull throttle, propeller and mixture controls are located on the control console. The throttle and propeller controls are released for repositioning by pushing a button on the knob. With the button extended, fine adjustments are accomplished by rotating the knob, clockwise to increase and counterclockwise to decrease. Do not rotate clockwise with control fully advanced. The mixture control may be repositioned by pushing or pulling and locked into position by rotating the knob clockwise.

### **COWLING (F33)**

The Bonanza is equipped with Hartwell latch mechanisms on the right and left upper engine cowling for quick and easy access to the engine compartments without the aid of tools. Each cowl latch is locked and released by a single recessed handle located in the lower cowling panel on each side of the engine. To close the cowling requires only to lower the cowling to the closed position with the handle in the prelatch position. The handle has three positions: flush with the fuselage - latched; held fully forward - unlatched (open cowling); approximately 90° to the fuselage - prelatch (ready to close cowl). An audible click denotes the bayonet fittings, located forward and aft on the upper cowl, sliding into the latch safety catch. The cowl is locked by moving the latch handle to the full recessed position. The

security of the forward latches can be checked by pulling out on the check tab attached to the lower forward edge of the upper cowling. If the cowling can be moved after latching, open the cowling, check the latch alignment and re-latch.

### **INDUCTION SYSTEM ICING**

The possibility of induction system icing is reduced by the non-icing characteristics of the fuel injected engine and the automatic alternate air source. Under certain conditions, however, impact ice can form at several points in the induction system. If the air intake or filter becomes clogged with ice, a spring-loaded door in the air intake duct will open automatically and the induction system will operate on alternate air. If the alternate air source door becomes frozen in the closed position, a pull-and-release T-handle is provided to force the door open.

### **LUBRICATION SYSTEM**

The engine oil system is the full pressure, wet sump type and has a 10-quart capacity. Oil operating temperatures are controlled by an automatic thermostat bypass control. The bypass control will limit oil flow through the oil cooler when operating temperatures are below normal and will permit the oil to bypass the cooler if it should become blocked.

### **STARTER**

The starter is relay-controlled and is actuated by a rotary type, momentary-on switch incorporated in the magneto/start switch. To energize the starter circuit, rotate the magneto/start switch beyond the BOTH position to START. After starting, release the switch to the BOTH position.

## **PROPELLER**

McCaughey constant speed, two blade propeller

Hub: 2A36C23

Blades: 84B-0

Diameter: Maximum 84 in., Minimum 82 in.

Pitch settings at 30 in. sta.:

Low 12°, High - not under 29.2°

or

(Optional on C33 only)

Hartzell constant speed, three blade propeller

Hub: Hartzell PHC-A3VF-4

Blades: V8433-4R

Diameter: Maximum 80 in., Minimum 78-1/4 in.

Pitch settings at 30 in. sta.:

Low - 10.8° ± 0.2°

High - not under 32°

Propeller rpm is controlled by a governor which regulates hydraulic oil pressure to the blades. A push-pull knob on the control console allows the pilot to select the governor's rpm range.

If governor oil pressure is lost, the propeller will go to the full high rpm position. This is because propeller low rpm is obtained by governor boosted engine oil pressure working against the centrifugal twisting moment of the blades.

## **FUEL SYSTEM**

The airplane is designed for operation on 80/87 grade (red) aviation gasoline. In the event this grade is not available only a higher rated fuel shall be used.

### *CAUTION*

Before refueling, make certain the airplane and fuel dispensing unit are properly grounded. Failure to do so creates a fire hazard.

## **FUEL CELLS**

Either the 44-gallon usable (50-gallon capacity) standard fuel system or the 74-gallon usable (80-gallon capacity) optional fuel system is available. The fuel system consists of a rubber fuel cell in each wing leading edge with a flush type filler cap. A visual measuring tab is attached to the filler neck of the optional system. The bottom of the tab indicates 27 gallons of usable fuel and the detent on the tab indicates 32 gallons of usable fuel in the tank provided the wings are level.

The engine driven fuel injector pump delivers approximately 10 gallons of excess fuel per hour, which bypasses the fuel control and returns to the tank being used. Three fuel drains are provided, one in each fuel sump on the underside of each wing and one in the fuel selector valve inboard of the left wing root. These points should be drained daily before the first flight.

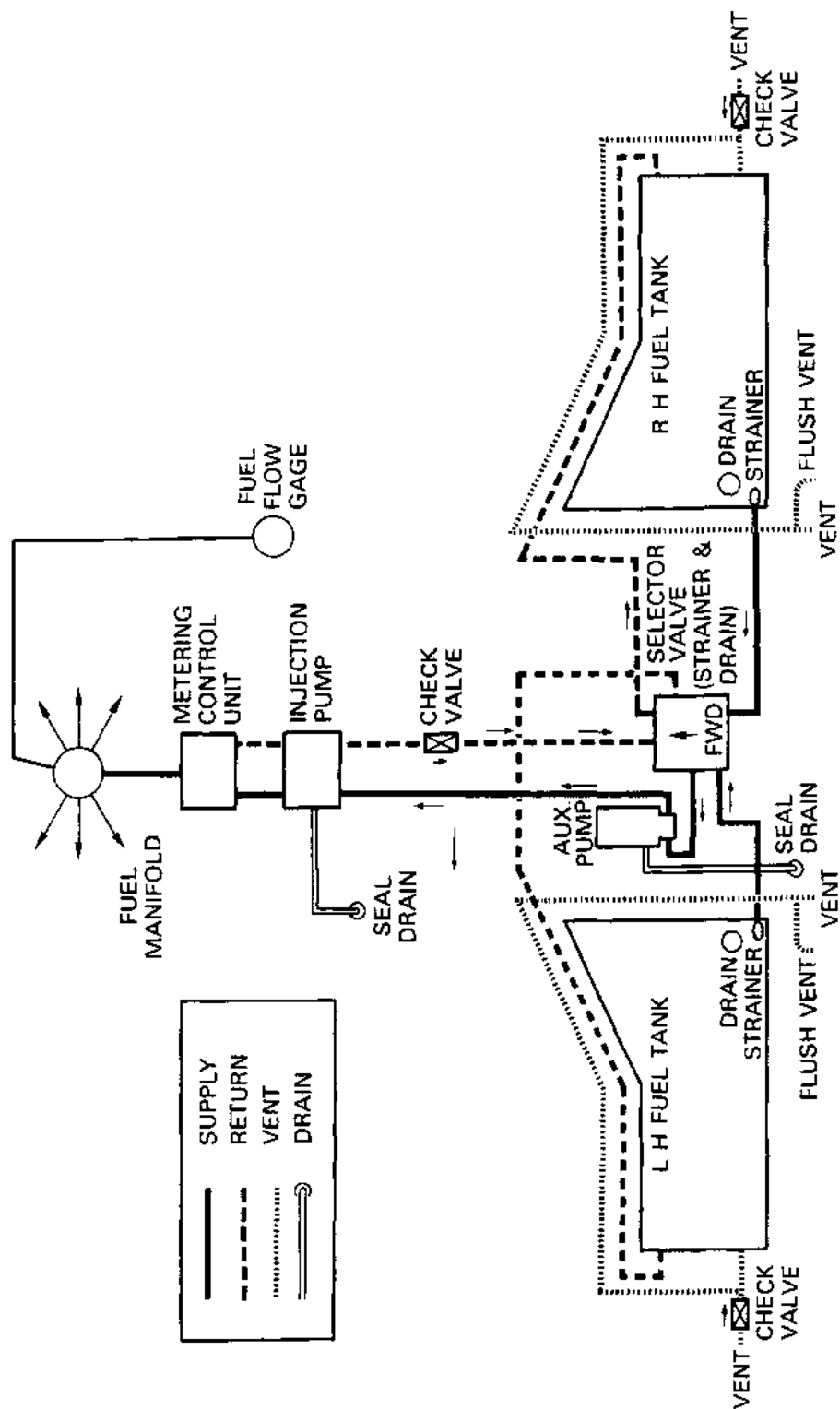

**FUEL SYSTEM SCHEMATIC**

## **FUEL QUANTITY INDICATION SYSTEM**

Fuel quantity is measured by float operated sensors, located in each wing tank system. These transmit electrical signals to the individual indicators that indicate fuel remaining in the tank. There are sensors in each wing tank system connected to the individual wing tank indicator.

## **AUXILIARY FUEL PUMP**

The electric auxiliary fuel pump is controlled by an ON-OFF toggle switch on the control console. It provides pressure for starting and emergency operation. Immediately after starting, the auxiliary fuel pump can be used to purge the system of vapor caused by an extremely high ambient temperature or a start with the engine hot. The auxiliary fuel pump provides for near maximum engine performance should the engine driven pump fail.

## **FUEL TANK SELECTION**

The fuel selector valve handle is located forward and to the left of the pilot's seat. Take-offs and landings should be made using the tank that is more nearly full.

If the engine stops because of insufficient fuel, refer to the EMERGENCY PROCEDURES Section for the Air Start procedures.

## **FUEL REQUIRED FOR FLIGHT**

It is the pilot's responsibility to ascertain that the fuel quantity indicators are functioning and maintaining a reasonable degree of accuracy, and be certain of ample fuel for a flight. Takeoff is prohibited if the fuel quantity

indicators do not indicate above the yellow arc. An inaccurate indicator could give an erroneous indication of fuel quantity. A minimum of 13 gallons of fuel is required in each tank before takeoff.

The filler caps should be removed and fuel quantity checked to give the pilot an indication of fuel on board. The airplane must be approximately level for visual inspection of the tank. If the pilot is not sure that at least 13 gallons are in each tank, add necessary fuel so that the amount of fuel will be not less than 13 gallons per tank at takeoff. Plan for an ample margin of fuel for any flight.

## **ELECTRICAL SYSTEM**

The system circuitry is the single-wire, ground-return type, in which the airplane structure itself is used as the ground return.

### **C33, E33**

The battery ON-OFF switch, the generator/alternator ON-OFF switch, and the magneto/start switch are located on an escutcheon at the left of the instrument panel. The circuit breaker panel extends across the base of the instrument panel and contains the protective circuit breakers for the various electrical systems.

### **F33**

The battery ON-OFF switch, the generator/alternator ON-OFF switch, and the magneto/start switch are located on the left subpanel. The circuit breaker panel is located on the right subpanel and contains circuit breakers for the various electrical systems. Some switch-type circuit breakers are located on the left subpanel.

## **BATTERY**

A 35 ampere-hour, 12-volt battery is located on the right forward side of the firewall. Battery servicing procedures are described in the **HANDLING, SERVICING AND MAINTENANCE** section.

## **GENERATOR**

Direct-current electric power is supplied by a 12-volt engine-driven generator of 35 ampere capacity, controlled by a voltage-current regulator which automatically adjusts generator output to its load, including recharging the battery. The generator circuit breaker is installed on the left side of the nose wheel well bulkhead.

The ammeter is of the conventional charge-discharge type, showing the rate of charge or discharge of the battery. A zero reading, which should be the normal condition in cruising flight, indicates that the battery is fully charged and the generator output has been adjusted by the regulator to balance the load of electrical equipment then in use.

## **ALTERNATOR**

A 60-ampere, 12-volt, gear-driven alternator is optional equipment. The alternator is designed to maintain its full rated 60-ampere output at 900 rpm.

A transistorized voltage regulator adjusts alternator output to the required electrical load, including battery recharging. Charge or discharge of the battery is indicated by the ammeter. A zero reading, which is normal for cruising flight, indicates that the battery is fully charged and that alternator output has been adjusted by the voltage regulator to balance the load of the electrical equipment in use.

The alternator field circuit breaker is located on the right sub-panel and the alternator output circuit breaker is installed on the left side of the nose wheel well cover.

Refer to the HANDLING, SERVICING AND MAINTENANCE Section for minor maintenance of the alternator.

## **EXTERNAL POWER RECEPTACLE**

The external power receptacle accepts a standard AN type plug. Before connecting an external power unit turn generator/alternator switch and avionic equipment OFF.

### ***CAUTION***

A negative ground external power source is required. Check polarity before using external power.

If the external power unit does not have a standard AN type plug, connect the positive lead from the external power source to the positive battery terminal and the negative lead to the negative battery terminal.

## **LIGHTING SYSTEM**

### **INTERIOR LIGHTING**

#### ***C33, E33***

Lighting for the instrument panel is furnished by a light in the cabin ceiling. It is controlled by the FLOOD LIGHTS rheostat control located below and to the right of the control column.

A RADIO and POST LIGHTS control rheostat is located to the left of the flood light rheostat. It controls the internal lights in the radio installation and individual instrument post lights.

**Section VII  
Systems Description**

**BEECHCRAFT  
Debonair C33  
Bonanza E33 and F33**

The cabin dome light is operated by an ON-OFF switch next to the light.

***F33***

Lighting for the instrument panel is controlled by thumb-rotated, disc-type rheostats, located on the pilot's sub-panel to the left of the control column. The first rheostat is labeled RADIO and ENG and controls the lighting of the avionics panel and the multiple readout engine instrument. The second rheostat labeled INST is optional and controls the lighting for the flight instruments, the omni indicators, and the instrument pressure gage.

On the lower subpanel are two more lighting rheostats, the first labeled SUB which controls the intensity of the complete subpanel lighting. The second rheostat is labeled FLOOD and controls the glareshield lighting which illuminates the full upper panel.

The cabin dome light is operated by an ON-OFF switch adjacent to the light. The optional reading lights above the rear seats have individual switches at the light. The optional map light has a press type switch on the wheel. The OAT and compass lights are controlled by a PUSH-ON, PUSH-OFF switch located adjacent to the OAT.

**EXTERIOR LIGHTING**

***C33, E33***

The switches for all of the exterior lights are located on the pilot's right subpanel.

The exterior lights consist of navigation lights on the wing tips and tail cone, rotating beacon (optional), and a landing light. For longer battery and lamp life, use the landing light sparingly; avoid prolonged operation which could cause overheating during ground maneuvering.

*F33*

The switches for all of the exterior lights are located on the pilot's left subpanel. Each switch is the circuit breaker type which will open the switch if it becomes overloaded or shorted.

The exterior lights consist of navigation lights on the wing tips and tail cone and a landing light. The landing light can be used for both approach and taxiing. For longer battery and lamp life, use the landing lights sparingly; avoid prolonged operation which could cause overheating during ground maneuvering.

**NOTE**

Particularly at night, reflections from anti-collision lights on clouds, dense haze or dust can produce optical illusions and intense vertigo. Such lights, when installed, should be turned off before entering an overcast; their use may not be advisable under instrument or limited VFR conditions.

**ENVIRONMENTAL SYSTEMS**

**CABIN HEATING**

A heater muffler on the right engine exhaust stack provides for heated air to five outlets in forward and aft areas of the cabin. Two forward outlets are located above and forward of each set of rudder pedals. One aft outlet is installed behind the right front seat and a second one under the right rear seat. The fifth outlet provides heated air for windshield defrosting.

**Section VII  
Systems Description**

**BEECHCRAFT  
Debonair C33  
Bonanza E33 and F33**

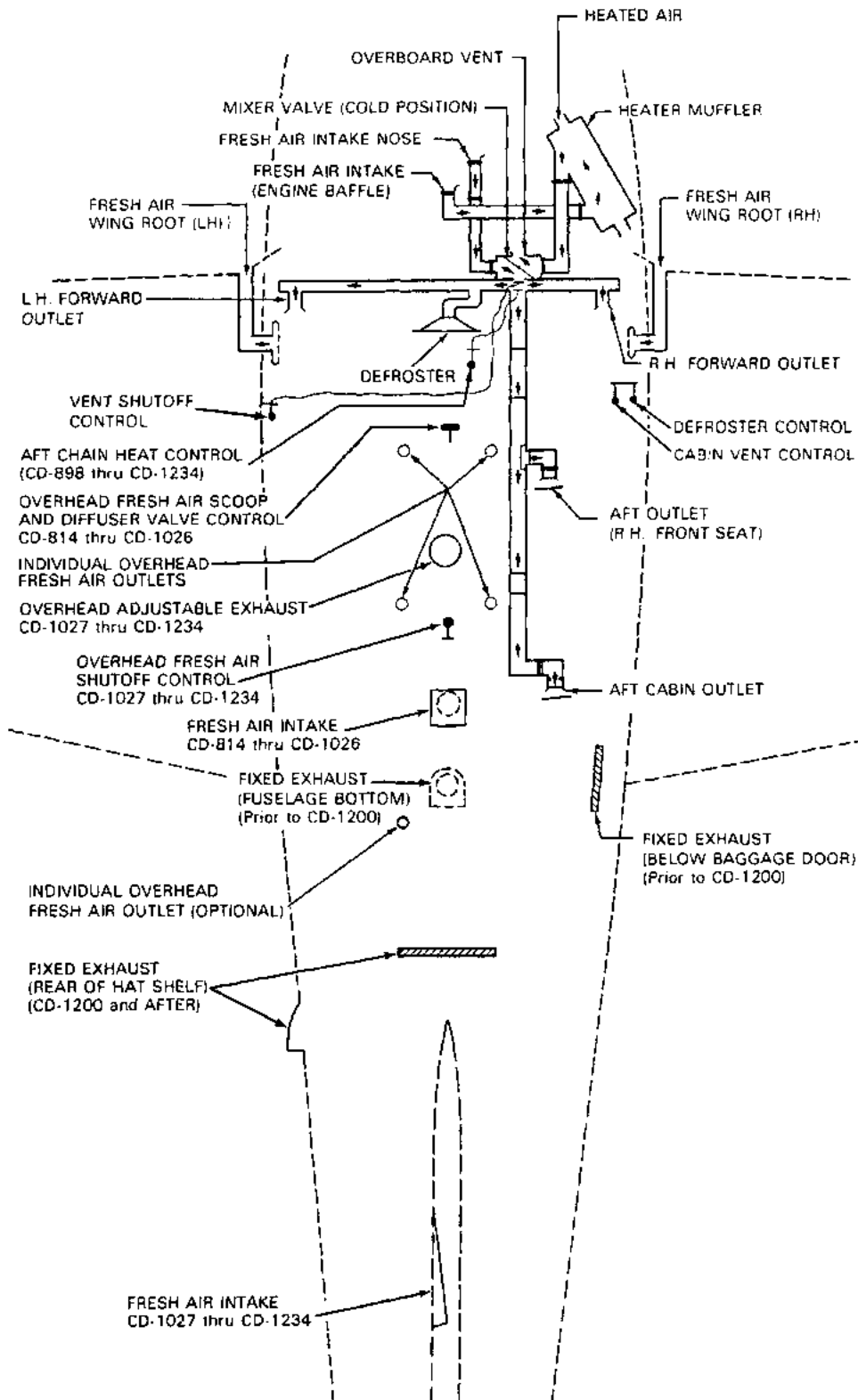

**HEATING AND VENTILATION SYSTEM SCHEMATIC  
C33, E33**

**BEECHCRAFT  
Debonair C33  
Bonanza E33 and F33**

**Section VII  
Systems Description**

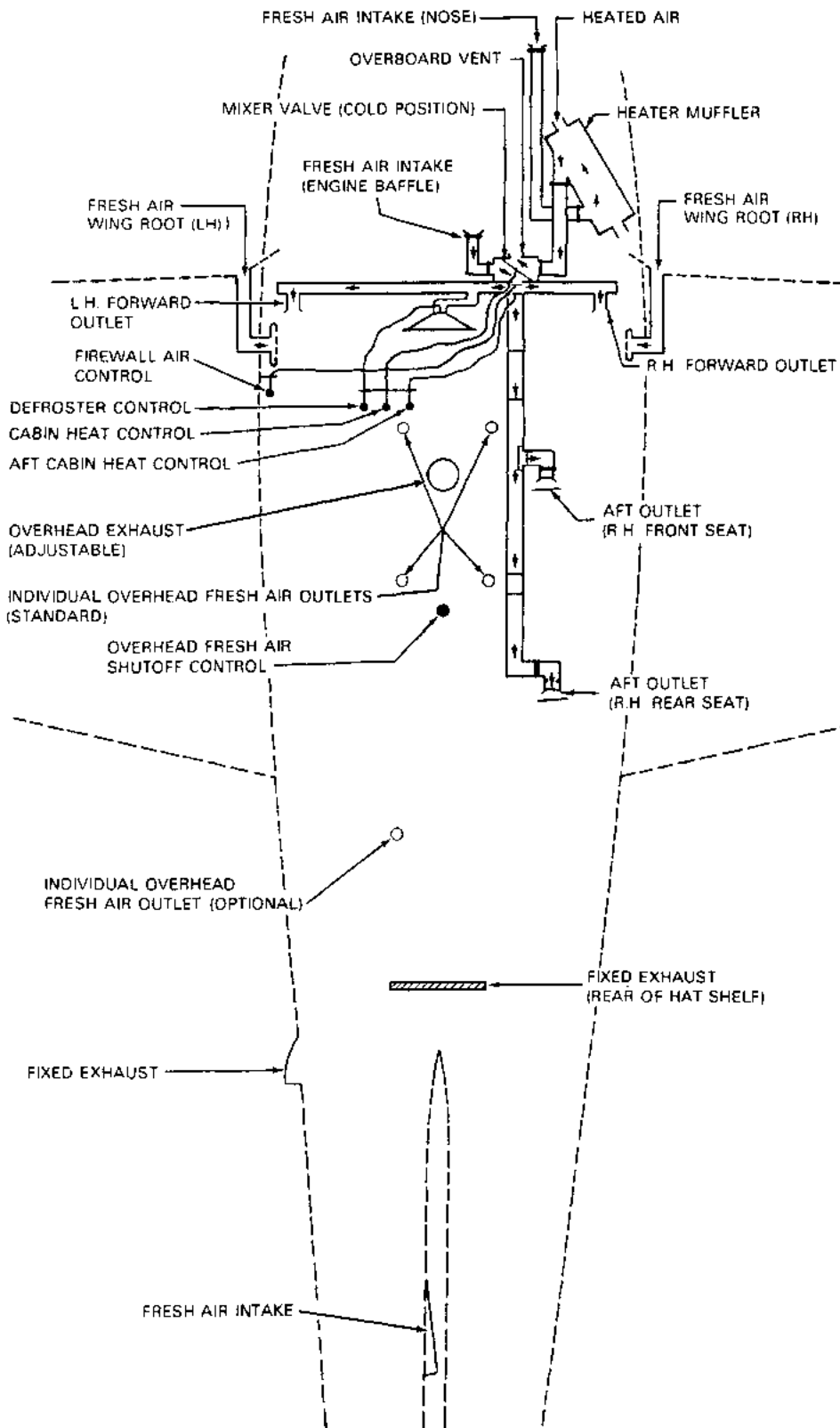

**HEATING AND VENTILATION SYSTEM SCHEMATIC  
F33**

On the C33 and E33, fresh ram air is picked up through an intake on the rear engine baffle, passes through the heater muffler, then into a mixer valve on the forward side of the firewall. In the mixer valve, the heated air is combined with a controlled quantity of unheated ram air which enters an intake on the right side of the nose. Air of the desired temperature is then ducted from the mixer valve to the outlets in the cabin.

On the F33, fresh ram air enters an intake on the right side of the nose, passes through the heater muffler, then into a mixer valve on the forward side of the firewall. In the mixer valve, the heated air is combined with a controlled quantity of unheated ram air picked up at an intake at the rear engine baffle. Air of the desired temperature is then ducted from the mixer valve to the outlets in the cabin.

#### **HEATER AND DEFROSTER OPERATION**

The cabin heat control is located on the upper right sub-panel in the C33 and E33 models and on the lower left subpanel in the F33. To provide heated air to the cabin outlets, pull the CABIN HEAT control. The control regulates the amount of cold air that is mixed with the air from the heater muff. When the control is pulled fully out, the cold air is shut off and only heated air enters the cabin.

To deliver heated air to the aft seat outlets, either push (C33, E33) or pull (F33) the AFT CABIN HEAT control. For maximum heat, the control is moved to full open position. To obtain heated air for defrosting the windshield pull the DEFROST control out. It may be necessary to vary or close the AFT CABIN HEAT control to obtain maximum air flow for defrosting. To close off all air from the heater system, pull the red control located at the extreme left of the pilots' lower subpanel. It is placarded either VENT SHUTOFF (C33, E33) or FIREWALL AIR (F33).

## **CABIN VENTILATION**

In moderate temperatures, ventilation air can be obtained from the same outlets used for heating, by pushing the CABIN HEAT control full forward. However, in extremely high temperatures, it may be desirable to pull the VENT SHUTOFF (FIREWALL AIR) control and use only the fresh air outlets described in the following paragraphs.

### *CABIN FRESH AIR OUTLETS*

A duct in each wing root is connected directly to an adjustable outlet in the upholstery panel forward of each front seat. Airflow from the right outlet is controlled by a center knob. The volume of air from the left outlet is regulated, and the direction of airflow is controlled by rotating the louvered cover with the small knob on the rim. The large knob in the center of this outlet is a friction lock which may be tightened to hold the valve position selected.

#### *Individual Overhead Fresh Air Outlets*

*(CD-814 thru CD-1026)*

A manually retractable air scoop on top of the cabin conducts outside air to individual fresh-air outlets in the overhead upholstery panel above each seat. The outlets can be manually adjusted to control both the quantity and direction of air flow. The air scoop may be closed by operating a push-pull control located on the overhead panel. Adjacent to the fresh air outlets in the overhead upholstery panel, a manually controlled diffuser valve admits fresh air to the cabin and distributes it in all directions.

*(CD-1027 thru CD-1254)*

Fresh ram air from the air intake on the upper side of the aft fuselage is ducted to individual outlets above each seat, including the optional seat. Each outlet can be positioned to direct the flow of air as desired. The volume of incoming air can be regulated by rotating the outlet. A system shutoff valve is installed in the duct between the overhead fresh air scoop and the individual fresh air outlets. The valve is operated by a push-pull control in the overhead panel.

#### **EXHAUST VENTS**

*(CD-814 thru CD-1199)*

Air is exhausted from the cabin through a fixed vent below the baggage compartment door which flows to an exhaust vent in the belly.

*(CD-1027 thru CD-1254)*

A manually controlled cabin air exhaust vent is located aft of the radio speaker in the overhead panel.

*(CD-1200 thru CD-1254)*

A fixed exhaust vent is provided through the rear of the hat shelf.

#### **OXYGEN SYSTEM**

The oxygen cylinder is located beneath the cover under the front seats. The system is available with either four or five outlets and with either a 38, 49 or 114 cu ft oxygen cylinder. Supply of oxygen to the system is controlled by a shut-off valve on the oxygen console. The pressure gage indicates the supply of oxygen available (1850 psig is nominal pressure for a full supply in the cylinder).

The system regulator is altitude compensated to provide a varying flow of oxygen with altitude. Flow is varied automatically from 0.5 liters per minute at 5,000 feet to 3.5 liters per minute at 30,000 feet. The use oxygen is recommended to be in accordance with current FAR operating rules.

## **PITOT AND STATIC SYSTEMS**

### **PITOT SYSTEM**

The pitot system provides a source of impact air for operation of the airspeed indicator. The pitot mast is located on the leading edge of the left wing.

#### *PITOT HEAT (Optional)*

The pitot mast is provided with an electric heating element which is turned on and off with a switch on the instrument panel. The switch should be ON when flying in visible moisture. It is not advisable to operate the pitot heating element on the ground except for testing or for short intervals of time to remove ice or snow.

### **NORMAL STATIC AIR SYSTEM**

The normal static system provides a source of static air to the flight instruments through a flush static fitting on each side of the airplane fuselage. Drain moisture accumulations from the system (CD-814 thru CD-1013) by opening the access door on the side panel in the rear baggage compartment and removing the section of rubber hose. On later models (CD-1014 thru CD-1254), the rear baggage compartment bulkhead must be removed to gain access to the drain plug, located at the low point of the normal static system. The closure bulkhead is held in place with Velcro and may be removed by pulling forward. The system should be drained every 100 hours and after exposure to visible moisture, either in the air or on the ground.

## **EMERGENCY STATIC AIR SYSTEM**

An emergency static air source, if installed, provides air for instrument operation should the static ports become blocked. Refer to the EMERGENCY PROCEDURES Section for procedures describing how and when to use this system.

## **VACUUM SYSTEM (C33)**

Vacuum for air driven gyroscopic flight instruments and other air driven equipment is supplied by an engine driven vacuum pump. An adjustable relief valve controls suction by bleeding outside air into the vacuum pump. The relief valve and an oil separator, which removes oil from the air, are located on the forward side of the firewall.

A suction gage indicates system vacuum in inches Hg. This instrument is located on the instrument panel; exact location may vary according to panel configuration. The vacuum should be maintained within the green arc for proper operation of the air driven instruments.

## **INSTRUMENT PRESSURE SYSTEM (E33, F33)**

Instrument pressure is supplied by an engine driven pressure pump. Pressure is controlled by an adjustable pressure regulator on the forward side of the firewall.

A pressure gage indicates system pressure in inches Hg. This instrument is located on the instrument panel; exact location may vary according to panel configuration. The pressure should be maintained within the green arc for proper operation of the pressure operated instruments.

## **STALL WARNING**

A stall warning horn on the forward side of the instrument panel sounds a warning signal as the airplane approaches a stall condition. The horn is triggered by a sensing vane on the leading edge of the left wing and is effective at all flight attitudes. Irregular and intermittent at first, the warning signal will become steady as the airplane approaches a complete stall.

## **ENGINE BREAK-IN INFORMATION**

Use a straight mineral oil as recommended by the engine manufacturer throughout the break-in period. Drain the initial oil at 20 to 30 hours, replace with new mineral oil which is to be used until oil consumption stabilizes, usually a total of about 50 hours.

Drain and replace the engine oil as recommended in **HANDLING, SERVICING AND MAINTENANCE**. If operating conditions are unusually dusty or dirty, more frequent oil changes may be necessary. Oil changes are more critical during the break-in period than at any other time.

Use full throttle at recommended rpm for every take-off and maintain until at least 400 feet AGL, then reduce as necessary for cruise climb or cruise. Maintain the highest power recommended for cruise operations during the break-in period, avoiding altitudes above 8000 feet. Interrupt cruise power every 30 minutes or so by smoothly advancing to take-off power settings for about 30 seconds, then returning to cruise power settings.

Avoid long power-off descents especially during the break-in period. Maintain sufficient power during descent to permit cylinder head temperatures to remain in the green arc.

**Section VII**  
**Systems Description**

**BEECHCRAFT**  
**Debonair C33**  
**Bonanza E33 and F33**

Minimize ground operation time, especially during warm weather. During the break-in period, avoid engine idling in excess of 15 minutes, especially in high ambient temperatures.

## **SECTION VIII**

# **HANDLING, SERVICING AND MAINTENANCE**

### **TABLE OF CONTENTS**

<i>SUBJECT</i>	<i>PAGE</i>
Introduction .....	8-5
Publications .....	8-6
Airplane Inspection Periods .....	8-7
Preventative Maintenance That May Be Accomplished By A Certificated Pilot .....	8-9
Alterations or Repairs to Airplane .....	8-9
Ground Handling .....	8-10
Towing .....	8-10
Parking .....	8-11
Tie-Down .....	8-11
Main Wheel Jacking .....	8-12
Prolonged Out of Service Care .....	8-12
Flyable Storage - 7 to 30 Days .....	8-12
Mooring .....	8-12
Engine Preparation For Storage .....	8-13
Fuel Cells .....	8-13
Flight Control Surfaces .....	8-13
Grounding .....	8-13
Pitot Tube .....	8-13
Windshield and Windows .....	8-13
During Flyable Storage .....	8-14
Preparation For Service .....	8-14

**TABLE OF CONTENTS (Continued)**

<i>SUBJECT</i>	<i>PAGE</i>
External Power .....	8-15
Checking Electrical Equipment .....	8-15
Servicing .....	8-16
Fuel System .....	8-16
Fuel Cells .....	8-16
Fuel Drains .....	8-16
Fuel Strainers .....	8-17
Oil System .....	8-17
Oil Change Procedure .....	8-18
Battery .....	8-18
Tires .....	8-20
Shock Struts .....	8-20
To Inflate Struts .....	8-20
To Replenish Strut Hydraulic Fluid .....	8-21
Shock Strut Shimmy Damper .....	8-22
Brakes .....	8-23
Induction Air Filter .....	8-23
To Remove and Clean the Filter .....	8-23
Vacuum System .....	8-23
Instrument Pressure System .....	8-24
Propeller Blades .....	8-24
Oxygen System .....	8-25
Oxygen Cylinder Retesting .....	8-26
Minor Maintenance .....	8-27
Rubber Seals .....	8-27
Generator .....	8-27
Alternator .....	8-28
Magnetos .....	8-28
Cleaning .....	8-29
Exterior Painted Surfaces .....	8-29
Windshield and Windows .....	8-32
Interior .....	8-32

**TABLE OF CONTENTS (Continued)**

<i>SUBJECT</i>	<i>PAGE</i>
Engine .....	8-33
Recommended Servicing Schedule .....	8-34
Lubrication Points .....	8-40
Consumable Materials .....	8-46
Approved Engine Oils .....	8-50
Bulb Replacement Guide .....	8-52
Overhaul or Replacement Schedule .....	8-53
Special Conditions Cautionary Notice .....	8-53
Landing Gear .....	8-54
Power Plant .....	8-54
Fuel System .....	8-55
Instruments .....	8-56
Electrical System .....	8-56
Flaps and Flight Controls .....	8-57
Miscellaneous .....	8-57

**INTENTIONALLY LEFT BLANK**

## **INTRODUCTION**

The purpose of this section is to outline the requirements for maintaining the airplane in a condition equal to that of its original manufacture. This information sets the time frequency intervals at which the airplane should be taken to a BEECHCRAFT Aero or Aviation Center or International Distributor or Dealer for periodic servicing or preventive maintenance.

The Federal Aviation Regulations place the responsibility for the maintenance of this airplane on the owner and operator of the airplane who must ensure that all maintenance is done by qualified mechanics in conformity with all airworthiness requirements established for this airplane.

All limits, procedures, safety practices, time limits, servicing and maintenance requirements contained in this handbook are considered mandatory.

Authorized BEECHCRAFT Aero or Aviation Centers or International Distributors or Dealers will have recommended modification, service, and operating procedures issued by both FAA and Beech Aircraft Corporation, designed to get maximum utility and safety from the airplane.

If there is a question concerning the care of the airplane, it is important to include the airplane serial number in any correspondence. The C33 (CD-814 thru CD-1103) serial number appears on the model designation placard attached to the underside of the fuselage just forward of the tiedown. The designation placard on C33 (CD-1104 thru CD-1118), E33 and F33 models is attached to the side of the fuselage under the baggage door.

## **PUBLICATIONS**

The following publications are available through BEECHCRAFT Aero or Aviation Centers and International Distributors or Dealers:

- |                  |                             |
|------------------|-----------------------------|
| 1. Shop Manual   | 3. Service Instructions     |
| 2. Parts Catalog | 4. Various Inspection Forms |

## **NOTICE**

The following information may be provided to the holder of this manual automatically:

1. Original issues and revisions of Class I and Class II Service Instructions
2. Original issues and revisions of FAA Approved Airplane Flight Manual Supplements
3. Reissues and revisions of FAA Approved Airplane Flight Manuals, Flight Handbooks, Owner's Manuals, Pilot's Operating Manuals, and Pilot's Operating Handbooks

This service is free and will be provided only to holders of this handbook who are listed on the FAA Aircraft Registration Branch List or the BEECHCRAFT International Owners Notification Service List, and then only if listed by airplane serial number for the model for which this handbook is applicable. For detailed information on how to obtain "Revision Service" applicable to this handbook or other BEECH-

CRAFT Service Publications, consult a BEEHCRAFT Aero or Aviation Center, International Distributor or Dealer, or refer to the latest revision of BEEHCRAFT Service Instructions No. 0250-010.

### **AIRPLANE INSPECTION PERIODS**

1. FAA Required Annual Inspections.
2. BEEHCRAFT Recommended Inspection Guide.
3. Continuing Care Inspection Guide.
4. See "Recommended Servicing Schedule" and "Overhaul or Replacement Schedule" for further inspection schedules.

#### **NOTE**

In event of emergency gear or flap extension at speeds above the respective normal extension speeds, inspect gear retract rods, gear doors and flaps for damage or distortion before the next flight.

**INTENTIONALLY LEFT BLANK**

**PREVENTATIVE MAINTENANCE THAT MAY  
BE ACCOMPLISHED BY A CERTIFICATED PILOT**

1. A certificated pilot may perform limited maintenance. Refer to FAR Part 43 for the items which may be accomplished.

To ensure proper procedures are followed, obtain a BEECHCRAFT Shop Manual for performing preventative maintenance.

2. All other maintenance must be performed by licensed personnel.

**NOTE**

Pilots operating airplanes of other than U.S. registry should refer to the regulations of the registering authority for information concerning preventative maintenance that may be performed by pilots.

**ALTERATIONS OR REPAIRS TO AIRPLANE**

The FAA should be contacted prior to any alterations on the airplane to ensure the airworthiness of the airplane is not violated.

**NOTE**

Alterations and repairs to the airplane must be made by properly licensed personnel.

## **GROUND HANDLING**

The three-view drawing in Section 1 shows the minimum hangar clearances for a standard airplane. Allowances must be made for any special radio antennas.

### *CAUTION*

To ensure adequate propeller clearance, always observe recommended shock strut servicing procedures and tire inflation pressures.

## **TOWING**

One man can move the airplane on a smooth and level surface using a hand tow bar. Attach the tow bar to the tow lugs on the nose gear lower torque knee.

Where movement is restricted, two men can pivot the airplane on the main wheels. One man should push on the wing leading edge or hold the wing tip, while the other operates the tow bar.

### *CAUTION*

Do not exert force on the propeller or control surfaces. Do not place weight on the stabilizers to raise the nose wheel. When towing with a tug, limit turns to prevent damage to the nose gear. Do not attempt to tow airplane backward by the tail tie down ring.

Care should be used when removing the tow bar to prevent damage to the lubrication fittings on the landing gear.

## **PARKING**

The parking brake push-pull control is located on the sub-panel. To set the parking brakes, pull control out and depress both toe pedals until firm. Push the control in to release the brakes.

### ***CAUTION***

The parking brake should be left off and wheel chocks installed if the airplane is to be left unattended. Changes in ambient temperature can cause the brakes to release or to exert excessive pressures.

## **TIE-DOWN**

It is advisable to nose the airplane into the wind. Three tie-down lugs are provided: one on the lower side of each wing and a third at the rear of the fuselage.

1. Install the control column lock pin.
2. Chock the main wheels, fore and aft.
3. Using nylon line or chain of sufficient strength, secure the airplane at the three points provided. **DO NOT OVER TIGHTEN**; if the line at the rear of the fuselage is excessively tight, the nose may rise and produce lift due to the angle of attack of the wings.
4. Release the parking brake.

If high winds are anticipated, a vertical tail post should be installed at the rear tie-down lug, and a tie-down line attached to the nose gear.

## **MAIN WHEEL JACKING**

1. Check the shock strut for proper inflation to prevent damage to the landing gear door by the jack adapter and to facilitate installation of the adapter.

### ***CAUTION***

Persons should not be in or on the airplane while it is on a main wheel jack.

2. Insert the main wheel jack adapter into the main wheel axle.
3. A scissors-type jack is recommended for raising and lowering the wheel.

## **PROLONGED OUT OF SERVICE CARE**

Storage procedures are intended to protect the airplane from deterioration while it is not in use. The primary objectives of these measures are to prevent corrosion and damage from exposure to the elements.

Flyable Storage (7-30 days) has been considered here. For more extended storage periods, consult the Beech Airplane Shop Manual and Continental Service Bulletin M 74-9 or later issue.

### **FLYABLE STORAGE - 7 TO 30 DAYS**

#### ***MOORING***

If airplane cannot be placed in a hangar, tie down securely at the three points provided. Do not use hemp or manila rope. It is recommended a tail support be used to compress the nose strut and reduce the angle of attack of the wings. Attach a line to the nose gear.

### *ENGINE PREPARATION FOR STORAGE*

Engines in airplanes that are flown only occasionally tend to exhibit cylinder wall corrosion much more than engines that are flown frequently.

Run engine at least five minutes at 1200 to 1500 rpm with oil and cylinder head temperatures in the normal operating range.

Check for correct oil level and add oil if necessary to bring level to full mark.

### *FUEL CELLS*

Fill to capacity to minimize fuel vapor and protect cell inner liners.

### *FLIGHT CONTROL SURFACES*

Lock with internal and external locks.

### *GROUNDING*

Static ground airplane securely and effectively.

### *PITOT TUBE*

Install cover.

### *WINDSHIELD AND WINDOWS*

Close all windows and window vents. It is recommended that covers be installed over windshield and windows.

*DURING FLYABLE STORAGE*

Each seven days during flyable storage, the propeller shall be rotated by hand. After rotating the engine six revolutions, stop the propeller 60° or 120° from the position it was in.

**WARNING**

Before rotation of propeller blades, ascertain magneto/start switch is OFF, throttle in CLOSED position, and mixture control is in the IDLE CUT-OFF position. Always stand in the clear while turning propeller.

If at the end of 30 days airplane will not be removed from storage, the engine shall be started and run. The preferred method will be to fly the airplane for 30 minutes, and up to, but not exceeding normal oil and cylinder temperatures.

**PREPARATION FOR SERVICE**

Remove all covers and tape, clean the airplane and give it a thorough inspection, particularly wheel wells, flaps, control surfaces and all openings.

Preflight the airplane.

## **EXTERNAL POWER**

When using external power, it is very important that the following precautions be observed:

1. The airplane has a negative ground system. Exercise care to avoid reversed polarity. Be sure to connect the positive lead of the external power unit to the positive terminal of the airplane's external power receptacle and the negative lead to the negative terminal of the external power receptacle. A positive voltage must also be applied to the small guide pin.
2. To prevent arcing, make certain no power is being supplied when the connection is made.
3. Make certain that the battery switch is ON, all avionics and electrical switches OFF, and a battery is in the system before connecting an external power unit. This protects the voltage regulators and associated electrical equipment from voltage transients (power fluctuations).

## **CHECKING ELECTRICAL EQUIPMENT**

Connect an auxiliary power unit as outlined above. Ensure that the current is stabilized prior to making any electrical equipment or avionics check.

### ***CAUTION***

If the auxiliary power unit has poor voltage regulation or produces voltage transients the equipment connected to the unit may be damaged.

## **SERVICING**

### **FUEL SYSTEM**

#### *FUEL CELLS*

See Consumable Materials for recommended fuel grades.

#### *CAUTION*

Never leave the fuel cells completely empty for more than a few days, as the cell inner liners may dry out and crack, permitting fuel to diffuse through the walls of the cell after refueling. If the cells are to be left empty for a week or more, a thin coating of light engine oil should be sprayed or flushed onto the inner liner of the cells.

The standard fuel cell installation consists of a 25-gallon capacity fuel cell (22-gallon usable) and filler cap in each wing leading edge. In the optional installation a 40-gallon capacity fuel cell (37-gallon usable) replaces the smaller capacity cell. The filler neck in this installation contains a visual measuring tab to permit partial filling of the tank. Filling the tank until the fuel touches the bottom of the tab indicates 27 gallons of usable fuel, and filling to the slot in the tab indicates 32 gallons of usable fuel. The airplane must be level for the tabs to indicate accurately.

#### *FUEL DRAINS*

Open the three snap-type fuel drains daily to purge any water from the system. Each fuel cell drain is located on the bottom of the wing just outboard of the fuselage. The system low spot drain is at the bottom of the fuel selector valve. The drain is accessible through a door in the fuselage adjacent to the left wing.

### *FUEL STRAINERS*

At each 50 hour inspection the strainer plug should be removed from the fuel injection control valve and the fuel injection control valve screen washed in fresh cleaning solvent. After the strainer plug has been reinstalled and safetied, the installation should be checked for leakage. The strainer at the bottom of the fuel selector valve should also be removed and cleaned with solvent every 100 hours. To reduce the possibility of contaminated fuel, always cap any disconnected fuel lines or fittings.

Ordinarily the finger strainers in the fuel cell outlets should not require cleaning unless there is a definite indication of solid foreign material in the cells or the airplane has been stored for an extended period.

### **OIL SYSTEM**

#### *CAUTION*

During break-in periods on new engines, oil consumption tends to be higher, therefore, maximum range flights should be avoided and oil level brought to full after each flight during this period.

On the C33 and E33 the engine oil filler cap and the dipstick are accessible by opening the access door on the left upper engine cowl. The left engine cowl must be raised to check or fill the oil tank on the F33. The sump capacity is 10 quarts. Normal operating level should be 8 to 10 quarts.

The oil should be changed and the oil screen should be cleaned every 50 hours under normal operating conditions. To assure complete drainage, the engine should be at operating temperature.

*OIL CHANGE PROCEDURE*

1. Remove the access plate from the engine cowl on the lower right side.
2. Locate the oil sump drain plug at the low point of the engine sump.
3. Remove the plug button below the sump drain and insert the oil drain duct.
4. Remove the oil sump drain plug.
5. Remove the oil screen and flush thoroughly. Replace the screen.
6. Replace the oil sump drain plug and fill the engine with oil.

See Consumable Materials and Approved Engine Oils for specified oils.

The engine manufacturer recommends ashless dispersant oils. In order to promote faster ring seating and oil control, a straight mineral oil should be used for the first oil change period or until oil consumption stabilizes. Oils must meet Teledyne Continental Motors Specification MHS-24B. Refer to APPROVED ENGINE OILS.

**BATTERY**

The battery is accessible by opening the right engine cowling. Check the electrolyte level after each 25 hours of operation and add distilled water as necessary. Do not overfill the battery.

Excessive water consumption may be an indication that the voltage regulator requires resetting. The specific gravity of the electrolyte should be checked periodically and maintained within the limits placarded on the battery.

The battery box is vented overboard to dispose of electrolyte and hydrogen gas fumes discharged during the normal charging operation. To ensure disposal of these fumes the vent tube should be checked frequently for obstructions and should be kept open.

## **TIRES**

An inflation pressure of 30 psi should be maintained on the 6.00 x 6 main wheel tires. The 5.00 x 5 nose wheel tire should be inflated to 40 psi. Maintaining proper tire inflation will minimize tread wear and aid in preventing tire failure caused from running over sharp stones. When inflating tires, visually inspect them for cracks and breaks.

### *CAUTION*

Beech Aircraft Corporation cannot recommend the use of recapped tires. Recapped tires have a tendency to swell as a result of the increased temperature generated during takeoff. Increased tire size can jeopardize proper function of the landing gear retract system, with the possibility of damage to the landing gear doors and retract mechanism.

## **SHOCK STRUTS**

The following procedures may be used for servicing both the main and the nose gear shock struts.

### *TO INFLATE STRUTS:*

1. Check to see that the airplane is empty except for full fuel and oil.
2. While rocking the airplane gently to prevent possible binding of the piston in the barrel, inflate the main gear shock strut until the piston is extended 3 inches. Inflate the nose gear shock strut until the piston is extended 3-1/2 or 5 inches as indicated on the nose gear shock strut servicing placard.

*CAUTION*

If a compressed air bottle containing air under extremely high pressure is used, exercise care to avoid over-inflating the shock strut.

**WARNING**

**NEVER FILL SHOCK STRUTS WITH OXYGEN.**

3. Remove all foreign material from the exposed piston with a soft cloth moistened with hydraulic fluid.

*TO REPLENISH STRUT HYDRAULIC FLUID:*

1. Support the airplane on jacks at the wing jack points.
2. Remove the air valve cap, depress the valve core, and allow the strut to fully deflate.
3. Raise and block the strut 1/4 inch from the compressed position.

**WARNING**

Do not remove the valve body assembly until all air pressure has been released or it may blow off, causing injury to personnel or damage to equipment.

4. Carefully remove the valve body assembly.
5. Fill the strut to the level of the valve body assembly with hydraulic fluid (see Consumable Materials).
6. Slowly extend the strut from the blocked position and replace the valve body assembly.

7. Depress the valve core and completely compress the strut to release excess air and oil.
8. Inflate the strut as described in the preceding inflation procedure.

### **SHOCK STRUT SHIMMY DAMPER**

The shimmy damper has a reservoir of fluid carried in the piston rod. Two coil springs installed in the piston rod keep fluid in the shimmy damper under pressure. As fluid is lost through leakage it is automatically replenished from the reservoir until the reservoir supply is exhausted.

To check the fluid level in the shimmy damper, insert a wire, approximately 1/32 inch in diameter, through the hole in the disc at the aft end of the piston rod until it touches the bottom of the hole in the floating piston. Mark the wire, remove it, and measure the depth of the insertion. When the shimmy damper is full, insertion depth is 2-3/16 inches, when empty, 3-1/16 inches.

### **NOTE**

The measuring wire should be inserted in the hole in the floating piston rather than against the piston face to give a more accurate reading. To determine if the wire is inserted in the hole in the floating piston, insert the wire several times, noting insertion depth each time. When the wire is inserted in the hole, the depth will be about 1/4 inch greater than when it rests against the piston face.

When the shimmy damper is found empty or nearly empty, it should be refilled. See Shop Manual.

## **BRAKES**

The brake hydraulic fluid reservoir is located on the firewall in the engine compartment. A dipstick is attached to the reservoir cap. Refer to Consumable Materials for hydraulic fluid specification.

The brakes require no adjustments since the pistons move to compensate for lining wear.

## **INDUCTION AIR FILTER**

This filter should be inspected for foreign matter at least once during each 50-hour operating period. In adverse climatic conditions, or if the airplane is stored, preflight inspection is recommended.

### ***TO REMOVE AND CLEAN THE FILTER:***

1. Remove the fuselage nose section grill.
2. Remove the wing nuts securing the filter and remove the filter.
3. Clean as described in the manufacturer's instructions on the filter.

## **VACUUM SYSTEM**

The vacuum system incorporates two screens; a relief valve screen and an oil separator screen. These screens should be cleaned every 100 hours. If the airplane is operated in dusty conditions, the screens should be cleaned more frequently.

Clean the suction relief valve screen by removing and washing in cleaning solvent. Remove and clean the oil separator screen by backflushing or submerging the unit in cleaning fluid. Blow dry with air pressure.

The filter assemblies on the air driven instruments should be replaced every 100 hours under normal operating conditions, and more often if operated under dusty conditions.

### **INSTRUMENT PRESSURE SYSTEM**

The pressure system incorporates two filters; a pump intake filter and an in-line filter. The pump intake filter is mounted on the rear engine baffle. The foam rubber suction screen should be washed with soap and water every 100 hours of normal operation. If the aircraft is operated in dusty conditions the filter should be cleaned more frequently. The in-line filter is located between the pressure regulator and the instruments. This filter should be changed every 300 hours of operation.

### **PROPELLER BLADES**

The daily preflight inspection should include a careful examination of the propeller blades for nicks and scratches.

Each blade leading edge should receive particular attention. It is very important that all nicks and scratches be smoothed out and polished. The BEECHCRAFT Aero or Aviation Center and International Distributors or Dealers will be glad to answer any questions concerning propeller blade repair.

### **WARNING**

When servicing a propeller, always make certain the ignition switch is off and that the engine has cooled completely. **WHEN MOVING A PROPELLER, STAND IN THE CLEAR;** there is always some danger of a cylinder firing when a propeller is moved.

### **OXYGEN SYSTEM**

*To service the oxygen system, use the following procedures:*

### **WARNING**

Keep hands, tools, clothing, and oxygen equipment clean and free from grease and oil. **KEEP FIRE AND SPARKS AWAY FROM OXYGEN.** Use only recommended leak testing soaps.

1. On earlier model Debonairs (prior to CD-932), check cylinder pressure by slowly opening the shut-off valve on the oxygen console forward and to the left of the pilot seat. On later model Debonairs (serial CD-932 and after), the cylinder pressure is connected directly to the pressure gage on the console.
2. The gage will not indicate pressure unless the shut-off valve on the oxygen cylinder is open. When the 38 or 49 cu. ft. cylinder is installed, the shut-off valve is located under the pilot's seat. When the 114 cu. ft. cylinder is installed, it is located under the copilot's seat.

*CAUTION*

Open the cylinder shutoff valve slowly to prevent damage to the system.

3. Close the cylinder shutoff valve and the console panel shutoff valve.
4. Slide the pilot's or copilot's seat aft until the filler valve is clear, then remove the cap from the filler valve and attach the recharging outlet. Open valve on supply bottle slowly.
5. Open the cylinder shutoff valve and slowly fill the cylinder to  $1850 \pm 50$  psi at a temperature of  $70^{\circ}\text{F}$ . This pressure may be increased an additional 3.5 psi for each degree of increase in temperature. Similarly, for each degree of drop in temperature, reduce the cylinder pressure 3.5 psi.
6. Close the cylinder shutoff valve, close the supply bottle valve, remove the recharging outlet, and replace the filler valve cap.
7. Slowly open the cylinder shutoff valve to prepare the system for use.
8. Reinstall the access panel and slide the pilot's seat forward to its original position.
9. The console panel shutoff valve should remain closed until the system is used.

*OXYGEN CYLINDER RETESTING*

The oxygen cylinders, (light weight cylinders, stamped "3HT" on the plate on the side) must be hydrostatically tested every three years and the test date stamped on the

cylinder. This cylinder has a service life of 4380 pressurizations or twenty-four years, whichever occurs first, and then must be discarded. The oxygen cylinders stamped 3A or 3AA must be hydrostatically tested every five years. The cylinder life is not limited on these cylinders.

## **MINOR MAINTENANCE**

### **RUBBER SEALS**

To prevent sticking of the rubber seals around the windows, doors, and engine cowling, the seals should be coated with Oakite 6 compound. The compound is noninjurious to paint and can be removed by employing normal cleaning methods.

### **GENERATOR**

Since the generator and voltage regulator are designed for use on only one polarity system, the following precautionary measures must be observed when working on the charging circuit, or serious damage to the electrical equipment will result:

1. When installing a battery, make certain that the ground polarity of the battery and the ground polarity of the generator are the same.
2. When connecting a booster battery, be sure to connect the negative battery terminals together and the positive battery terminals together.
3. When using a battery charger, connect the positive lead of the charger to the positive battery terminal and the negative lead of the charger to the negative battery terminal.

## **ALTERNATOR**

Since the alternator and voltage regulator are designed for use on only one polarity system, the following precautionary measures must be observed when working on the charging circuit, or serious damage to the electrical equipment will result:

1. When installing a battery, make certain that the ground polarity of the battery and the ground polarity of the alternator are the same.
2. When connecting a booster battery, be sure to connect the negative battery terminals together and the positive battery terminals together.
3. When using a battery charger, connect the positive lead of the charger to the positive battery terminal and the negative lead of the charger to the negative battery terminal.
4. Do not operate an alternator on open circuit. Be sure all circuit connections are secure.
5. Do not short across or ground any of the terminals on the alternator or voltage regulator.
6. Do not attempt to polarize an alternator.

## **MAGNETOS**

Ordinarily, the magnetos will require only occasional adjustment, lubrication, and breaker point replacement. This work should be done by a BEECHCRAFT Aero or Aviation Center or International Distributor or Dealer.

### **WARNING**

To be safe, treat the magnetos as hot whenever a switch lead is disconnected at any point; they do not have an internal automatic grounding device. The magnetos can be grounded by replacing the switch lead at the noise filter capacitor with a wire which is grounded to the engine case. Otherwise, all spark plug leads should be disconnected or the cable outlet plate on the rear of the magneto should be removed.

### **CLEANING**

#### **EXTERIOR PAINTED SURFACES**

### **WARNING**

Do not expose control surface trim tab hinge lines and their pushrod systems to the direct stream or spray of high-pressure, soap-and-water washing equipment. Fluid dispensed at high pressure could remove the protective lubricant, allowing moisture from heavy or prolonged rain to collect at hinge lines, and then to freeze at low temperatures. After high-pressure or hand washing, and at each periodic inspection, lubricate trim tab hinge lines and trim tab pushrod end fittings (Brayco 300 per Federal Specification VV-L-800 preferred). See Consumable Materials.

*CAUTION*

When cleaning landing gear areas with solvent, especially if high-pressure equipment is used, exercise care to avoid washing away grease from landing gear components. After washing the landing gear areas with solvent, lubricate all lubrication points, or premature wear may result.

Do not apply wax, polish, rubbing compound, or abrasive cleaner to any uncured painted surface. Use of such items can permanently damage the surface finish. Also, waxes and polishes seal the paint from the air and prevent curing.

*CAUTION*

Alkyd enamel (sometimes called "automotive enamel"), acrylic enamel, lacquer, and dope finishes require a curing period of approximately 90 days; Acrylic urethane, polyester urethane, and epoxy finishes undergo a curing process for a period of 30 days after application. Wash uncured painted surfaces with a mild non-detergent soap (MILD detergents can be used on urethane finishes) and cold or lukewarm water only. Use soft cloths, keeping them free of dirt and grime. Any rubbing of the surface should be done gently and held to a minimum to avoid damaging the paint film. Rinse thoroughly with clear water. Stubborn oil or soot deposits may be removed with automotive tar removers.

Prior to cleaning, cover the wheels, making certain the brake discs are covered. Attach the pitot cover securely, and plug or mask off all other openings. Be particularly careful to mask off all static air buttons before washing or waxing. Use special care to avoid removing lubricant from lubricated areas.

When using high-pressure washing equipment, keep the spray or stream clear of wheel bearings, propeller hub bearings, etc., and openings such as pitot tubes, static air buttons, and battery and avionics equipment cooling ducts, which should be securely covered or masked off. Avoid directing high-pressure sprays toward the fuselage, wings, and empennage from the rear, where moisture and chemicals might more easily enter the structure, causing corrosion damage to structural members and moving parts.

Hand washing may be accomplished by flushing away loose dirt with clean water, then washing with a mild soap and water, using soft cleaning cloths or a chamois. Avoid harsh, abrasive, or alkaline soaps or detergents which could cause corrosion or scratches. Thorough clear-water rinsing prevents buildup of cleaning agent residue, which can dull the paint's appearance. To remove oily residue or exhaust soot, use a cloth dampened with an automotive tar remover. Wax or polish the affected area, if necessary.

There is some variation in the procedures required for proper care of the several types of exterior paint. During the curing period, do not make prolonged flights in heavy rain or sleet, and avoid all operating conditions which might cause abrasion or premature finish deterioration. Alkyd enamel, lacquer, and dope finishes must be polished and waxed periodically to maintain luster, and to assure protection from the weather. Acrylic enamel should be waxed, and may be polished, if desired. Acrylic urethane may be waxed

**INTENTIONALLY LEFT BLANK**

for protection from the elements, but should not be polished unless polishing or buffing is required to restore a damaged area. Waxing of polyester urethane finishes, although not required, is permitted; however, never use abrasive cleaner type waxes, polishes, or rubbing compounds, as these products cause eventual deterioration of the characteristic urethane gloss. Epoxy finishes should be waxed on a regular basis, and may be polished and buffed to restore appearance should "chalking" occur. For waxing, select a high quality automotive or aircraft waxing product. Do not use a wax containing silicones, as silicone polishes are difficult to remove from surfaces. A buildup of wax on any exterior paint finish will yellow with age; therefore, wax should be removed periodically. Generally, aliphatic naphtha (see Consumable Materials) is adequate and safe for this purpose.

**NOTE**

Before returning the airplane to service, remove all maskings and coverings, and re-lubricate as necessary.

## **WINDSHIELD AND WINDOWS**

The windshield and plastic windows should be kept clean and waxed at all times. To prevent scratches wash the windows carefully with plenty of soap and water, using the palm of the hand to feel and dislodge dirt and mud. A soft cloth, chamois or sponge may be used, but only to carry water to the surface. Rinse thoroughly, then dry with a clean, moist chamois. Rubbing the surface of the plastic with a dry cloth builds up an electrostatic charge which attracts dust particles in the air.

Remove oil and grease with a cloth moistened with isopropyl alcohol. Never use gasoline, benzine, alcohol, acetone, carbon tetrachloride, fire extinguisher fluid, anti-ice fluid, lacquer thinner or glass cleaner. These materials will soften plastic and may cause it to craze.

After thoroughly cleaning, the surface should be waxed with a good grade of commercial wax. The wax will fill in the minor scratches and help prevent further scratching. Apply a thin, even coat of wax and bring it to a high polish by rubbing lightly with a clean, dry, soft flannel cloth. Do not use a power buffer; the heat generated by the buffing pad may soften the plastic.

## **INTERIOR**

To remove dust and loose dirt from the upholstery, headliner, and carpet, clean the interior regularly with a vacuum cleaner.

Blot up any spilled liquid promptly with cleansing tissue or rags. Do not pat the spot; press the blotting material firmly and hold it for several seconds. Continue blotting until no more liquid is taken up. Scrape off sticky materials with a dull knife; then spot-clean the area.

Oily spots may be cleaned with household spot removers, used sparingly. Before using any solvent, read the instructions on the container and test it on an obscure place on the fabric to be cleaned. Never saturate the fabric with a volatile solvent; it may damage the padding and backing materials.

Soiled upholstery and carpet may be cleaned with foam-type detergent used according to the manufacturer's instructions. To minimize wetting the fabric, keep the foam as dry as possible and remove it with a vacuum cleaner.

The plastic trim, instrument panel, and control knobs need only be wiped with a damp cloth. Oil and grease on the control wheel and control knobs can be removed with a cloth moistened with isopropyl alcohol. Volatile solvents, such as mentioned in the article on care of plastic windows should never be used since they soften and craze the plastic.

## **ENGINE**

Clean the engine with neutral solvent. Spray or brush the fluid over the engine, then wash off with water and allow to dry.

### ***CAUTION***

Do not use solutions which may attack rubber or plastic. Protect engine switches, controls, and seals; fluid applied at high pressure can unseat seals, resulting in contamination of the sealed systems.

**RECOMMENDED SERVICING SCHEDULE**

INTERVAL	ITEM	LOCATION (Letters refer to Lubrication Points Diagram)	LUBRICANT (Number refers to item on Consumable Materials)
Pre-flight	Check engine oil level Drain fuel cell drains  Drain fuel system low spot drain Service fuel cells	Upper left side of engine Bottom of wing near wing root  Bottom of fuselage, left side  Top of wings, leading edge	5 - - 6
25 Hrs.	Check battery electrolyte	Under right cowling door	See Shop Manual
50 Hrs.	Change engine oil Clean fuel injection control valve screen Clean induction air filter Drain static air lines (C33 thru CD-1013)	Lower side of engine Lower engine compartment  Behind nose section grill Behind aft cabin side panel access door	5 7 - -

Section VIII  
Handling, Serv - Maint

BEECHCRAFT  
Debonair C33  
Bonanza E33 and F33

8-34

August 1982

August 1982

50 Hrs. (Cont.)	Drain static air lines (CD-1014 thru CD-1254)	Behind aft cabin bulkhead	-
	Lubricate landing gear retract mechanism and *uplock rollers	Wheel wells (K)	4
100 Hrs.	Clean fuel selector valve strainer	Left side belly	7
	Clean vacuum pump reg- ulator screen**	Engine compartment	7
	Inspect, replace the pressure pump intake filter as necessary**	Engine compartment	
	† Lubricate aileron control linkage	Each wing (J)	4, 10
	Lubricate cabin door mechanism	Aft edge of cabin door (E)	4
	Lubricate control column linkage	Forward of instrument panel (C)	4

BEECHCRAFT  
Debonair C33  
Bonanza E33 and F33

Section VIII  
Handling, Serv - Maint

8-35

\*Unless BEECHCRAFT S.I. 0448-211 has been complied with.

\*\*If Applicable

## RECOMMENDED SERVICING SCHEDULE

INTERVAL	ITEM	LOCATION (Letters refer to Lubrication Points Diagram)	LUBRICANT (Number refers to item on Consumable Materials)
100 Hrs. (Cont.)	Lubricate elevator and rudder control mechanism	Forward of tail bulk- head (H)	4
	Lubricate elevator tab chain	In each horizontal stabilizer (I)	4
	Lubricate landing gear door hinges	Edge of wheel well (L) (N)	4
	Lubricate landing gear retract mechanism and *uplock rollers	Wheel wells (A) (K)	3, 10
	Lubricate nose wheel steering mechanism	Nose wheel well (B)	3
	Lubricate rudder pedals	Cockpit (M)	4
	Lubricate trim tab control	Control pedestal (D)	4
	†† Lubricate wheel bearings and felt seals	Nose and main wheels (A, K)	1, 4

\*After BEECHCRAFT S.I. 0448-211 has been complied with.

**BEECHCRAFT**  
**Debonair C33**  
**Bonanza E33 and F33**

**Section VIII**  
**Handling, Serv - Maint**

300 Hrs.	Flap motor (brushes) Service landing gear actuator gear box Change pressure system in-line filter	Under front seats in cabin (G) Under front seats in cabin (F)  Forward of instrument panel	- 8  Airborne Mfg. 1J4-7
600 Hrs.	Service landing gear motor-reduction gears Service flap motor gear box	Under front seats in cabin (F)  Under front seats in cabin (G)	3  10
900 Hrs.	Lubricate flap actuators  Lubricate flap flex driveshafts	Inside wing aft of wheel well (G) Under floor in cabin	9  10
900 Hrs. or 5 years whichever comes first	Lubricate elevator tab actuators	Inside each horizontal stabilizer (I)	10

August 1982

8-37

**RECOMMENDED SERVICING SCHEDULE**

<b>INTERVAL</b>	<b>ITEM</b>	<b>LOCATION (Letters refer to Lubrication Points Diagram)</b>	<b>LUBRICANT (Number refers to item on Consumable Materials)</b>
As Req.	Clean spark plugs Service main and nose shock struts Service shimmy damper Drain static air lines (C33 thru CD-1013)	Engine compartment Landing gear  Nose gear Behind aft cabin side panel access door	- 2  2 .
	Remove one end of the hose which forms the static line drain and permit the system to drain.		
	Drain static air lines (CD-1014 thru CD-1254)	Behind aft cabin bulkhead	-
<p align="center"><b>NOTE</b></p> <p>The static air line should be drained frequently during periods of high humidity. Also drain the line each time the airplane is flown through heavy rain or is washed down.</p>			

8-38

August 1982

Section VIII  
Handling, Serv - Maint

BEECHCRAFT  
Debonair C33  
Bonanza E33 and F33

Note 3	Replace emergency locator transmitter battery	At emergency locator	-
--------	---	----------------------	---

- NOTES:
1. Anytime the control surfaces are altered, repaired, or repainted, they must be re-balanced per the Shop Manual.
  2. Check the wing bolts for proper torque at the first 100-hour inspection and at the first 100-hour inspection after each reinstallation of the wing attach bolts.
  3. Rechargeable Batteries: Recharge after one cumulative hour of use or after 50% of the useful charge life.

Non-rechargeable Batteries: Replace after one cumulative hour of use or after 50% of the useful charge life.

† Lubricate aileron control rod ends in place using SAE 20 or SAE 10W30 or remove aileron control rod assembly, clean and relubricate control rod ends using MIL-G-23827 grease. Rotate rod end bearings to assure adequate lubricant coverage. Check aileron rigging after reinstallation of rod end assembly.

†† Lightly saturate felt seals with 10W30 oil (remove excess by pressing slightly) also coat the sides and outer diameter with the same type of grease used on the bearings.

LUBRICATION POINTS

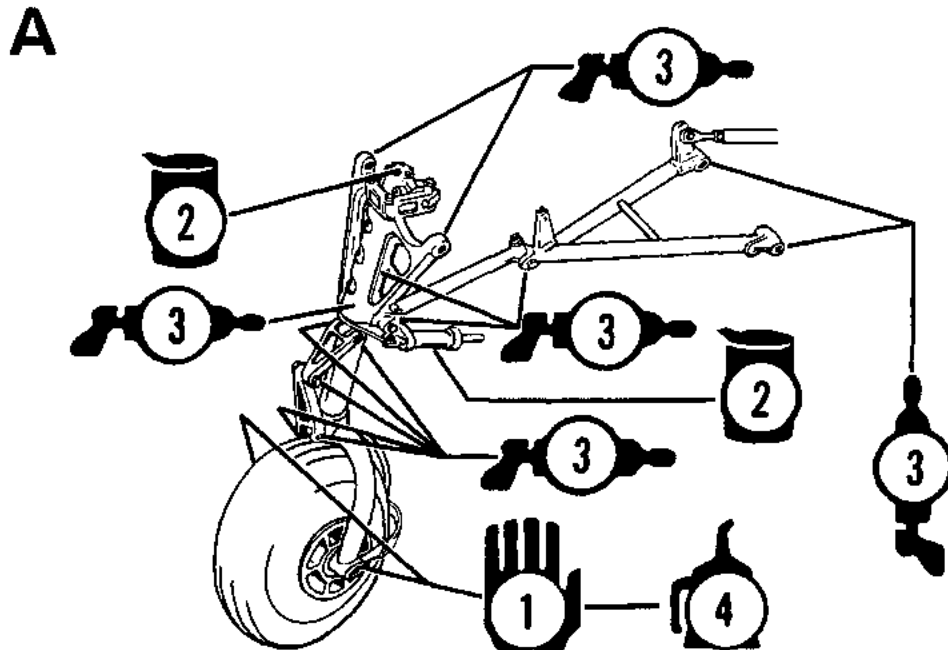
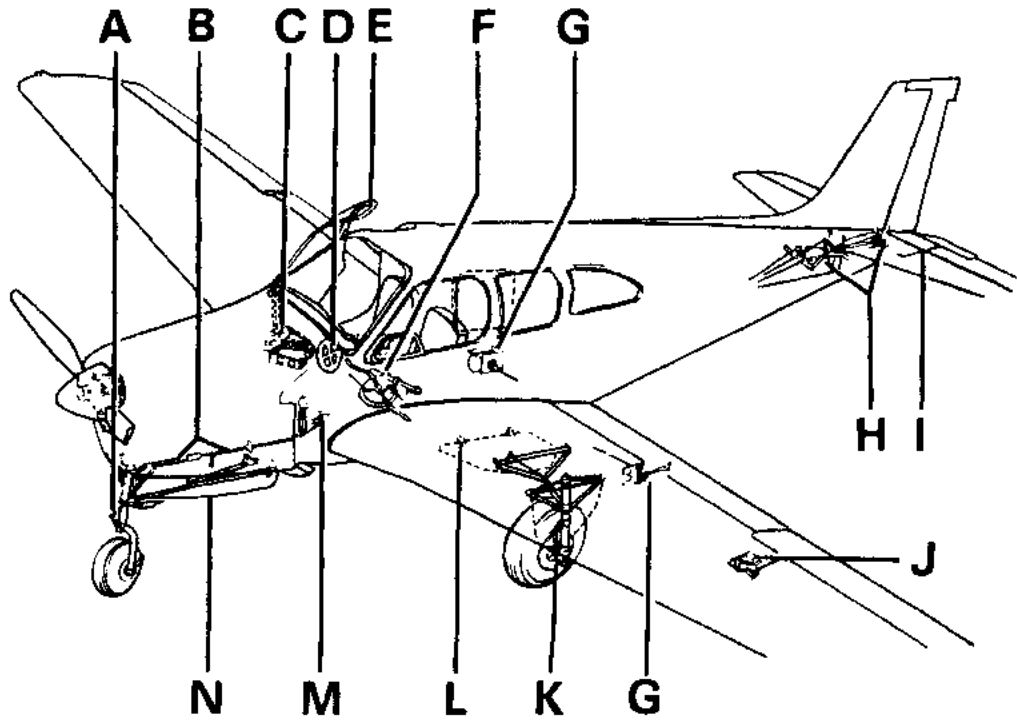

NOSE GEAR RETRACT

**B**

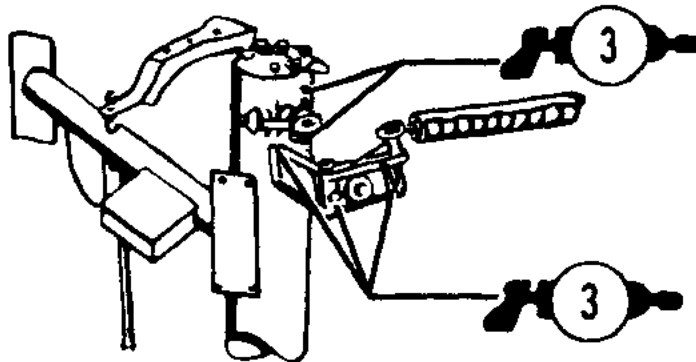

NOSE WHEEL STEERING

---

**C**

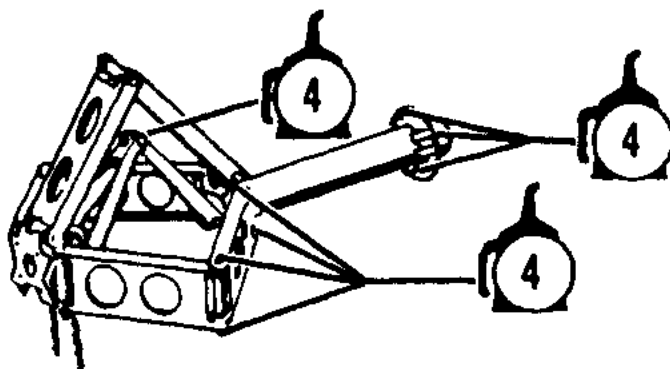

CONTROL COLUMN LINKAGE

---

**D**

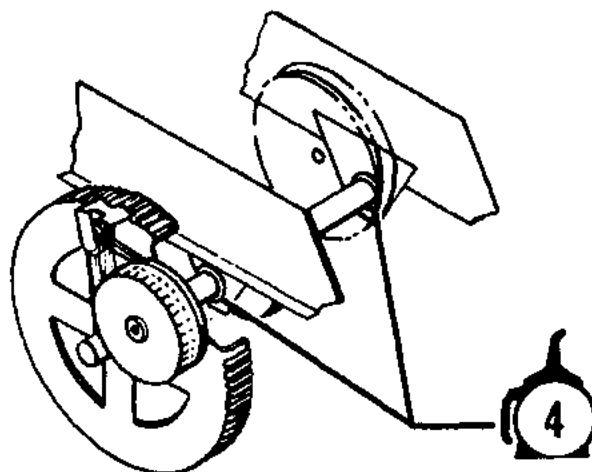

ELEVATOR TRIM CONTROL

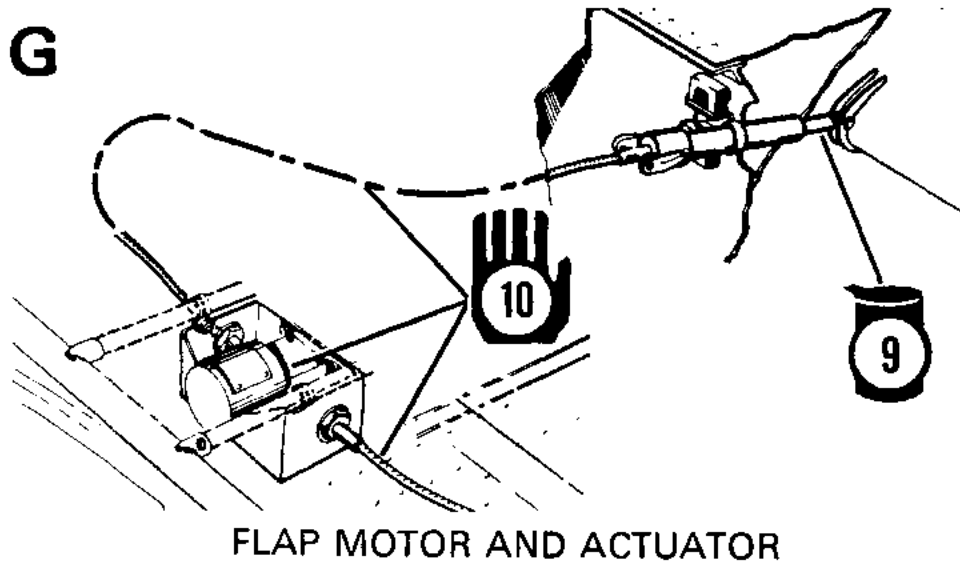
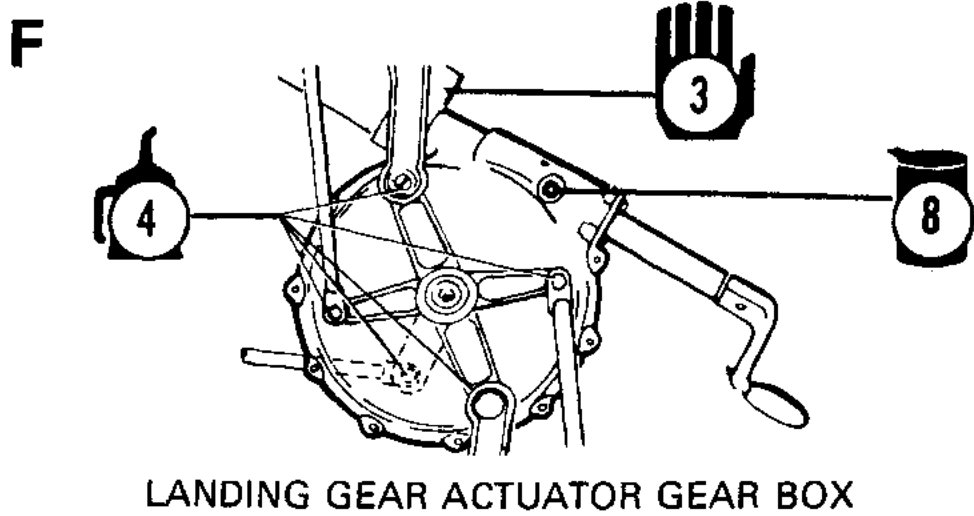
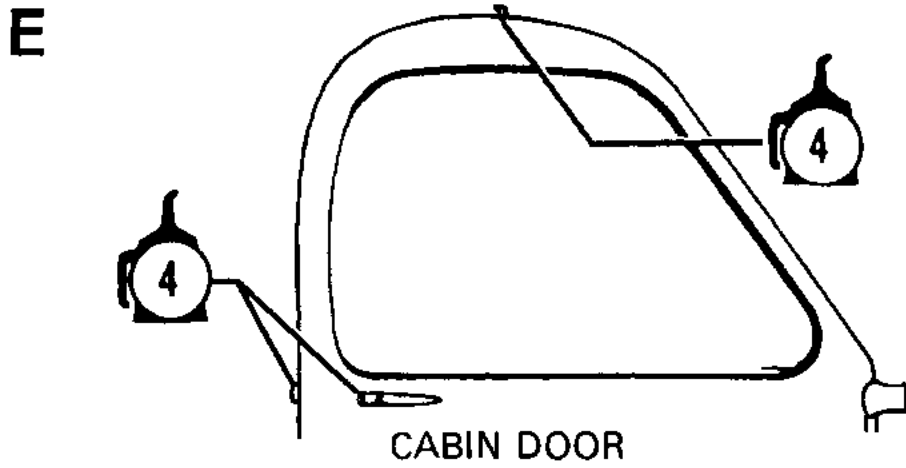

**H**

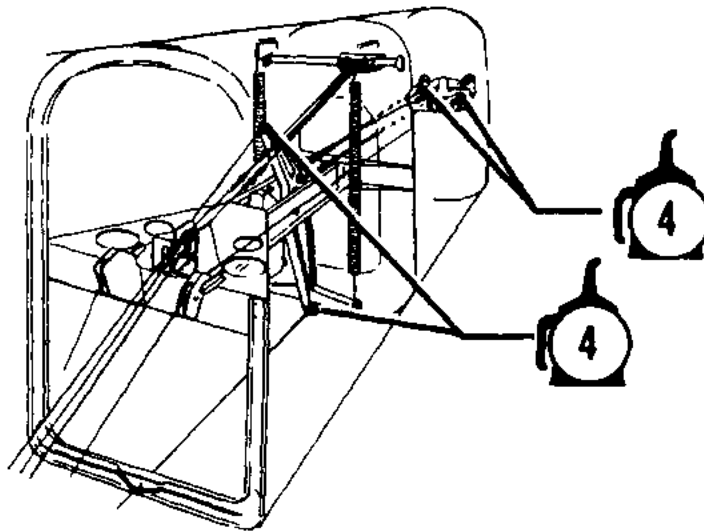

**ELEVATORS AND RUDDER CONTROL MECHANISM**

---

**I**

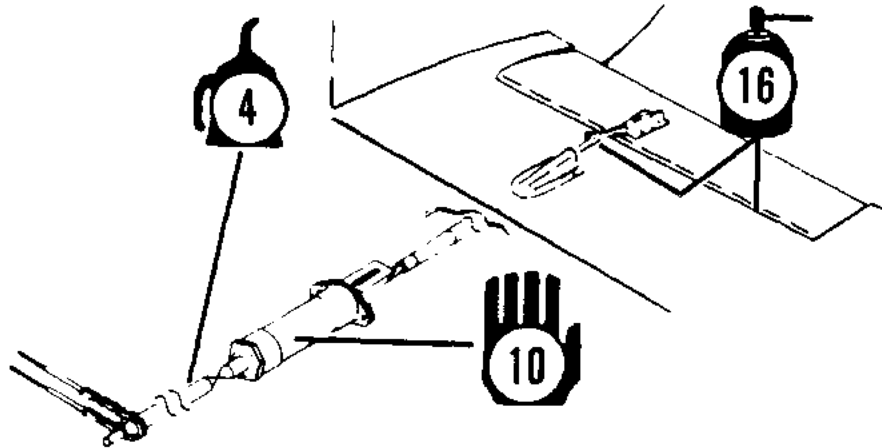

**ELEVATOR TAB MECHANISM**

---

**J**

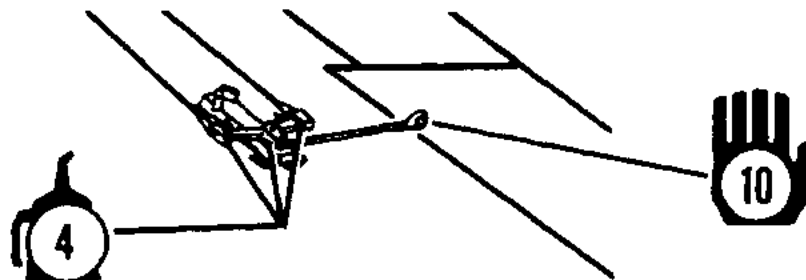

**AILERON BELL CRANKS**

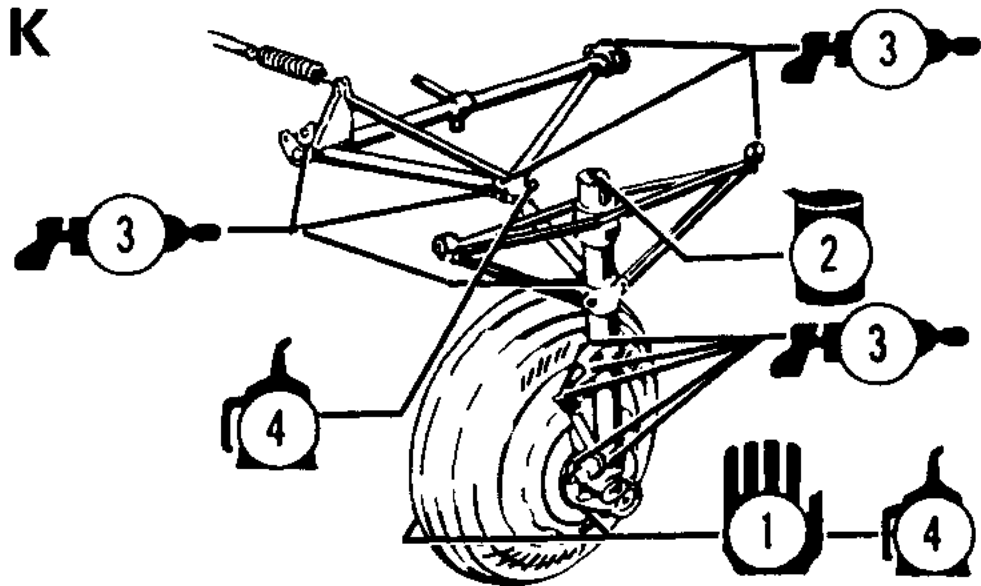

MAIN GEAR RETRACT

---

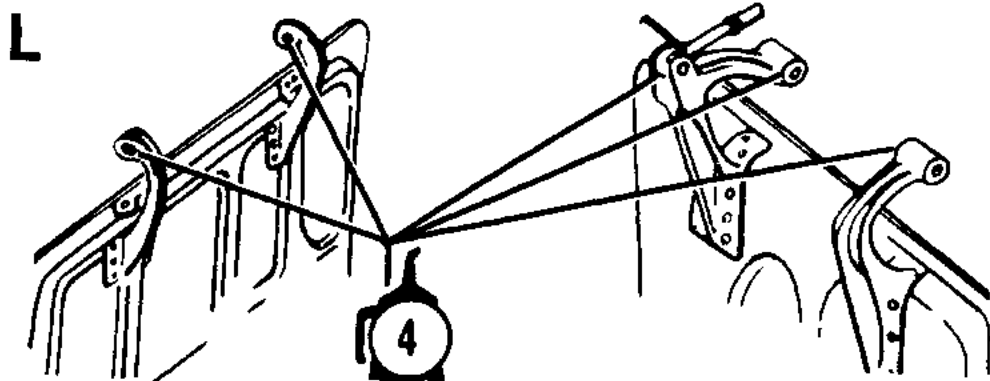

MAIN GEAR DOOR HINGES

---

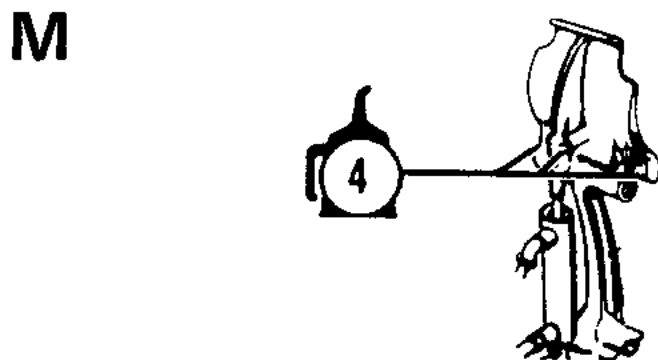

RUDDER PEDALS

**N**

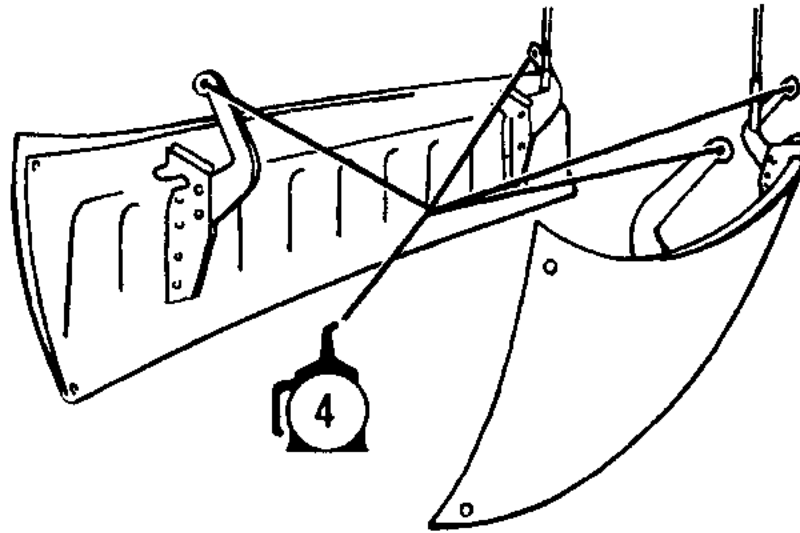

NOSE GEAR DOOR HINGES



HAND OR PACK



ZERK FITTING



FLUID CONTAINER



SQUIRT CAN



AEROSOL CAN

*NOTE: Letters are keyed to the Service Schedule; Numbers refer to items in the Consumable Materials Chart.*

## **CONSUMABLE MATERIALS**

Only the basic number of each Military Specification is included in the Consumable Materials Chart. No attempt has been made to update the basic number with the letter suffix that designates the current issues of the various specifications.

Vendors listed as meeting Federal and Military Specifications are provided as reference only and are not specifically recommended by Beech Aircraft Corporation; consequently, any product conforming to the specification listed may be used. The products listed below have been tested and approved for aviation usage by Beech Aircraft Corporation, by the vendor, or by compliance with the applicable specifications. Other products that are locally procurable which conform to the requirements of the applicable Military Specification may be used even though not specifically included herein.

It is the responsibility of the operator/user to determine the current revision of the applicable Military Specification prior to usage of that item. This determination may be made by contacting the vendor of a specific item.

**CONSUMABLE MATERIALS**

ITEM	MATERIAL	SPECIFICATION
1.	Lubricating Grease Wheel Bearing	Aeroshell No. 5 or MIL-G-81322
<i>CAUTION</i>		
Do not mix Aeroshell No. 5 with MIL-G-81322. Thoroughly clean grease from bearings and bearing area before changing grease.		
2.	Hydraulic Fluid	MIL-H-5606
*3.	Lubricating Grease, General Purpose, Wide Temperature	MIL-G-81322
4.	Lubricating Oil	SAE No. 20 or SAE10W-30
**5.	Engine Oil	SAE No. 30 (Below 40°F) SAE No. 50 (Above 40°F) Approved Multiviscosity Oils
***6.	Engine Fuel	Grade 80/87 (Red)
7.	Solvent	Federal Specification, PD680
8.	Lubricant	Mobil Compound GG or Mobil 636

**Section VIII  
Handling, Serv - Maint**

**BEEHCRAFT  
Debonair C33  
Bonanza E33 and F33**

ITEM	MATERIAL	SPECIFICATION
9.	Lubricating Oil, Gear	MIL-L-10324 or MIL-L-2105C, Grade 75W
10.	Grease, Aircraft and Instrument	MIL-G-23827
†11.	Lubricant, Rubber Seal	Oakite 6 Compound
12.	Naptha, Aliphatic	Federal Specification, TT-N-95
††13.	Tape, Anti-Seize, Tetrafluorethylene	MIL-T-27730
14.	Leak Test Compound, Oxygen Systems	MIL-L-25567
15.	Oxygen, Aviators Breathing	MIL-O-27210
16.	Lubricant	●BRAYCO 300 ●●CRC 3-36 ●●●LPS No. 1 ●●●●WD 40

**BEECHCRAFT  
Debonair C33  
Bonanza E33 and F33**

**Section VIII  
Handling, Serv - Maint**

- \* In extremely cold climates use MIL-G-23827 grease in place of MIL-G-81322. (These greases harmful to paint.)
- \*\* Ashless dispersant oil (Teledyne Continental Motors Corp. Spec. MHS-24B) recommended; straight mineral oils recommended during break-in period. See servicing data.
- \*\*\* If 80/87 (RED) grade fuel not available, use 100LL (BLUE) or 100 (GREEN) grade fuel.
- † Product of Oakite Products, Inc., 50 Valley Road, Berkley Heights, NJ 07922.
- †† For sealing tapered threads on high pressure oxygen lines.
  - Product of Bray Oil Co.,  
Los Angeles, Calif.
  - Product of CRC Chemicals, Inc.,  
Warminster, Pa. 18974
  - Product of LPS Research Laboratories, Inc.,  
2050 Cotner Ave,  
W. Los Angeles, Calif. 90025
  - Product of the WD-40 Company,  
1061 Cudahy Place,  
San Diego, Calif. 92110

**APPROVED ENGINE OILS**

<b>COMPANY</b>	<b>BRAND AND WEIGHT</b>
BP Oil Corporation	BP Aero Oil
Castrol Limited (Australia)	Castrolaero AD Oil
Continental Oil Co.	Conoco Aero S
Delta Petroleum Co.	Delta Avoil Oil
Exxon Company, U.S.A.	Exxon Aviation Oil EE
Gulf Oil Corporation	Gulfpride Aviation AD
Mobil Oil Company	Mobil Aero Oil
Pennzoil Company	Pennzoil Aircraft Engine Oil
Phillips Petroleum Co.	Phillips 66 Aviation Oil Type A  Phillips X/C Aviation Multiviscosity Oil SAE 20W-50  Phillips X/C Aviation Multiviscosity Oil SAE 25W-60
Quaker State Oil & Refining Corp.	Quaker State AD Aviation Engine Oil
Red Ram Limited (Canada)	Red Ram X/C Aviation Oil 20W-50

**BEECHCRAFT  
Debonair C33  
Bonanza E33 and F33**

**Section VIII  
Handling, Serv - Maint**

COMPANY	BRAND AND WEIGHT
Shell Canada, Ltd.	Aeroshell Oil W
Shell Oil Company	Aeroshell Oil W SAE 15W/50 Aeroshell Oil W
Sinclair Refining Co.	Sinclair Avoil
Texaco, Inc.	Texaco Aircraft Engine Oil - Premium AD
Union Oil Co. of California	Union Aircraft Engine Oil

**NOTE**

This chart lists all oils which were certified as meeting the requirements of Teledyne Continental Motors Specification MHS-24B at the time this handbook was published. Any other oil which conforms to this specification may be used.

**BULB REPLACEMENT GUIDE**

<b>LOCATION</b>	<b>NUMBER</b>
Compass light	330
Dome light, cabin	89
Elevator tab position indicator light (C33, E33)	53
(F33)	1813
Fuel selector placard light	53
Flap indicator lights (C33)	330
Engine instrument lights (C33)	1891R
Instrument light, overhead (C33, E33)	89
(F33)	1816
Instrument light, post (Optional)	330
Landing gear position light	330
Landing gear visual position light	53
Landing light	4313
Navigation light, tail cone	93
Navigation light, wing	1512
Rotating beacon (Grimes)	A-7079-12
Rotating beacon (Whelen)	WRM-44
Overvoltage warning light	330
Strobe lights	R4316

## **OVERHAUL OR REPLACEMENT SCHEDULE**

The first overhaul or replacement should be performed not later than the required period. The condition of the item at the end of the first period can be used as a criterion for determining subsequent periods applicable to the individual airplane or fleet operation, providing the operator has an approved monitoring system.

The time periods for inspection noted in this handbook are based on average usage and average environmental conditions.

## **SPECIAL CONDITIONS CAUTIONARY NOTICE**

Airplanes operated for Air Taxi or other than normal operation and airplanes operated in humid tropics or cold and damp climates, etc., may need more frequent inspections for wear, corrosion and/or lack of lubrication. In these areas periodic inspections should be performed until the operator can set his own inspection periods based on experience.

## **NOTE**

The required periods do not constitute a guarantee that the item will reach the period without malfunction, as the aforementioned factors cannot be controlled by the manufacturer.



**COMPONENT**

**OVERHAUL OR REPLACE**

Exhaust system	On condition
Starter	Inspect at engine overhaul, overhaul or replace on con- dition
Generator/Alternator	On condition
Oil cooler	On condition (replace when contaminated)
Propeller (Hartzell)	**1500 hours or 4 years.
Propeller (McCauley)	***1500 hours or 5 years.
Propeller controls	On condition
Propeller governor	At engine overhaul but not to exceed 1500 hours or 3 years
Fuel pressure pump	Every 1500 hours
Cabin heat muff	Inspect every 100 hours

**FUEL SYSTEM**

Fuel cells	On condition
Wing fuel quantity transmitters	On condition
Fuel cell drain valve	On condition
Fuel system check valves	On condition
Fuel selector valve	Inspect every 600 hours Overhaul every 1200 hours
Auxiliary fuel pump	Every 1200 hours
All hose	Hose carrying flammable liquids at engine overhaul or every 5 years. All other hose on condition.





**Section VIII  
Handling, Serv - Maint**

**BEECHCRAFT  
Debonair C33  
Bonanza E33 and F33**

\*Reference Teledyne Continental Motors Corporation Service Bulletin M81-22, dated November 2, 1981 or later issue.

With particular attention to throttle response, smooth power and oil consumption, a qualified certificated mechanic must determine that the engine is operating normally at the time of each periodic inspection.

\*\* Refer to Hartzell Propeller, Inc. Service Letter No. 61F, dated August 31, 1979, or later issue.

\*\*\* Applies only to propellers with hub serial number 71XXXX and higher; all other propellers; 1200 hours or 5 years.

# **SECTION IX**

## **SUPPLEMENTS**

### **NOTE**

The supplemental data contained in this section is for equipment that was delivered on the airplane including standard optional equipment that was available, whether it was installed or not. Supplements for equipment for which the vendor obtained a Supplemental Type Certificate were included as loose equipment with the airplane at the time of delivery. These and other Supplements for other equipment that was installed after the airplane was delivered new from the factory should be placed in this SUPPLEMENTS Section of this Pilot's Operating Handbook and FAA Approved Airplane Flight Manual.

**NOTE**

Supplements applicable to equipment other than that installed may, at the discretion of the owner/operator, be removed from the manual.

**PILOT'S OPERATING HANDBOOK  
and  
FAA APPROVED AIRPLANE FLIGHT MANUAL  
P/N 33-590002-9B  
LOG OF SUPPLEMENTS**

<i>FAA Supplements must be in the airplane for flight operation when subject equipment is installed</i>			
<b>Part Number</b>	<b>Subject</b>	<b>Rev No.</b>	<b>Date</b>
33-590013-3	Tactair T-3 Autopilot	3	9/77
33-500002-1	Tactair T-3AL and T-3ALL Autopilot	1	9/77
35-590110-13	Landing Gear Safety System	5	4/81
33-534033-9	Fifth Seat (Side Facing)	1	9/77
130694	Electrothermal Prop Deice	1	10/77
36-590002-39	Fuel Selector Valve Stop Installation		3/83
58-590000-49	Inside Cabin Door Handle With Open/Closed Placard		12/90

Supplements applicable to equipment other than that installed may, at the discretion of the owner/operator, be removed from the manual.

**BEECHCRAFT LANDPLANES  
35-33, 35-A33, 35-B33 and 35-C33**

**PILOT'S OPERATING HANDBOOK AND  
FAA APPROVED AIRPLANE FLIGHT MANUAL  
SUPPLEMENT**

for the

**TACTAIR T-3 AUTOPILOT**

**GENERAL**

This document is to be attached to the Pilot's Operating Handbook and FAA Approved Airplane Flight Manual when the airplane is equipped with a Tactair T-3 Autopilot, which has been installed in accordance with BEECHCRAFT FAA approved data.

The information in this document supersedes the Pilot's Operating Handbook only where covered in the items contained herein.

**LIMITATIONS**

1. Autopilot operation not certificated above 20,000 feet.
2. Do not use autopilot during take-off or landing.

**EMERGENCY PROCEDURES**

1. Maximum altitude lost during malfunctioning tests in cruise configuration, 100 feet.
2. Maximum altitude lost during malfunctioning test in approach configuration, 100 feet.
3. If a drop in suction below 3.5 is noted on the Instrument Suction Gage, push Master Pilot "OFF" to return instruments to normal flight operation. Check for leaks in Autopilot system at earliest convenience.

**FAA Approved  
Revised: September 1977  
P/N 33-590013-3**

4. The Autopilot can be disengaged by pushing the Master "ON-OFF" to the "OFF" position, in the event of malfunction. It can also be overpowered manually by exerting enough force on the controls to override the Autopilot.
5. Altitude Hold (if installed). If altitude deviates excessively from set altitude, disengage Altitude Hold by pushing knob in. Then reengage Altitude Hold as indicated above. If it still deviates, a malfunction exists, and the Altitude Hold should be disengaged. Check for leakage at the earliest convenience.

#### **NOTE**

- The Altitude Hold may be overpowered manually, however, upon release of the controls, the airplane will attempt to return to the set altitude, unless Altitude Hold is disengaged before changing altitude.

#### **NORMAL PROCEDURES**

##### **1. To Engage Autopilot:**

Trim airplane for cruising flight. Have Course Selector Card coincide with Directional Gyro heading.

Set Pitch Control Knob for level flight (raised pointer near center of Knob range).

Center the Turn Knob.

Pull Master "ON-OFF" to "ON" position to engage Autopilot.

If necessary, readjust Pitch Knob.

##### **2. Operation of Autopilot:**

**FAA Approved**  
**Revised: September 1977**  
**P/N 33-590013-3**

Pitch angle (climb or dive) can be controlled within limits by rotation of Pitch Control Knob. (Command limits are approximately 10° down, 15° up).

Controlled turns left or right, up to 26° bank angles, can be made by rotating Turn Control Knob off center. Operation of the Turn Knob off center disconnects the "Heading Lock".

When the Turn Knob is set at center for level flight, the "Heading Lock" button can be pushed in to provide heading reference to the Directional Gyro. Heading can be selected by setting the upper card of the Directional Gyro with the "Course" Selector Knob. Auto-pilot will bring airplane to desired heading if within 80° of either side of desired heading. Past 80°, the Heading Lock will turn the airplane to the reciprocal of the heading requested. All corrections using the Course Selector Knob have a turn rate of approximately 1° per second. The tab beneath the Turn Knob can be moved left or right to shift the roll zero point up to two degrees in the corresponding direction. When desired altitude is attained, engage Altitude Hold (if installed) by pulling out Altitude Hold Knob on right side of Command Control Unit.

Disengage Altitude Hold by pushing in Altitude Hold Knob whenever a change to another altitude is desired.

**PERFORMANCE - No change**

Approved:



Chester A. Rembleske  
Beech Aircraft Corporation  
DOA CE-2

**FAA Approved**  
**Revised: September 1977**  
**P/N 33-590013-3**

**3 of 3**

**BEECHCRAFT LANDPLANES  
35-C33, 35-C33A and E33A**

**PILOT'S OPERATING HANDBOOK AND  
FAA APPROVED AIRPLANE FLIGHT MANUAL  
SUPPLEMENT**

for the

**TACTAIR T-3AL and T-3ALL AUTOPILOT**

**GENERAL**

This document is to be attached to the Pilot's Operating Handbook and FAA Approved Airplane Flight Manual when the airplane is equipped with the Tactair T-3AL or T-3ALL Autopilot which has been installed in accordance with BEECHCRAFT FAA approved data.

The information in this document supersedes the Pilot's Operating Handbook and FAA Approved Airplane Flight Manual only where covered in the items contained herein.

**LIMITATIONS**

1. Autopilot operation not certificated above 20,000 feet.
2. Do not use autopilot during take-off or landing.

**EMERGENCY PROCEDURES**

1. Basic Autopilot

Maximum altitude lost during malfunctioning tests in cruise configuration, 100 feet.

Maximum altitude lost during malfunctioning test in approach configuration, 100 feet.

If a drop in suction below 3.5 is noted on the Instrument Suction Gage, push Master pilot "OFF" to return instruments to normal flight operation. Check for leaks in Autopilot system at earliest convenience.

The Autopilot can be disengaged by pushing the Master "ON-OFF" to the "OFF" position, in the event of malfunction. It can also be overpowered manually by exerting enough force on the controls to override the Autopilot.

## 2. Altitude Hold

If altitude deviates excessively from set altitude, disengage Altitude Hold by pushing knob in. Then re-engage Altitude Hold as indicated above. If it still deviates, a malfunction exists, and the Altitude Hold should be disengaged. Check for leakage at the earliest convenience.

### NOTE

The Altitude Hold may be overpowered manually, however, upon release of the controls, the airplane will attempt to return to the set altitude, unless Altitude Hold is disengaged before changing altitude.

## 3. Omni Lock

In the event of VOR or LOC mode malfunction, disengage Autopilot NAV Switch. It can also be manually overpowered by exerting enough force on the controls to override the Autopilot.

## **NORMAL PROCEDURES**

### **1. Basic Autopilot**

#### **a. To Engage Autopilot:**

- (1) Trim airplane for cruising flight.**
- (2) Have Altitude Hold knob "OFF".**
- (3) Have Omni Lock knob "OFF".**
- (4) Set Course Selector Card to coincide with Directional Gyro Heading.**
- (5) Set Pitch Control knob for level flight (red index mark near center of knob range).**
- (6) Center the Turn knob.**
- (7) Pull Master ON-OFF knob to "ON" position to engage autopilot.**
- (8) If necessary, readjust Pitch Control knob.**

#### **b. Operation of Basic Autopilot:**

**Pitch angle (climb or dive) can be controlled within limits by rotation of Pitch Control knob. (Command limits are approximately 10° down, 15° up.)**

**Controlled turns left or right, up to 26° bank angles, can be made by rotating Turn Control Knob off center. Operation of the Turn Knob off center disconnects the "Heading Lock".**

**When the Turn Knob is set at center of level flight, the "Heading Lock" button can be pulled out to provide heading reference to the Directional Gyro. Heading can be selected by setting the upper card of the Directional Gyro with the "Course" Selector Knob. Autopilot will bring airplane to desired heading if within 180° of either side of desired heading. All corrections using the Course Selector Knob have a turn rate of approximately two degrees per second. The tab beneath the Turn knob can be moved left or right to shift the roll zero point up to two degrees in the corresponding direction.**

**FAA Approved**

**Revised: September 1977**

**P/N 33-50002-1**

**3 of 7**

## 2. Altitude Hold

- a. When desired altitude is attained, engage Altitude Hold by pulling out Altitude Hold knob on face of Command Control unit.
- b. Disengage Altitude Hold by pushing in Altitude Hold knob whenever a change to another altitude is desired.

### NOTE

The Altitude Hold may be overpowered manually, however, upon release of the controls, the airplane will attempt to return to the set altitude, unless Altitude Hold is disengaged before changing altitude.

## 3. Omni Lock

- a. To Engage Omni Lock  
After takeoff and at a safe altitude, engage the Basic Autopilot as above.

Tune in Omni Station and set Omni Bearing Selector to the desired course.

Set the Directional Gyro Course Card to match the Omni Bearing Selector and select the HDG Switch to ON.

Engage the Omni Lock Switch (If Localizer Adapter is installed, select VOR-LOC Switch to VOR and Autopilot NAV Switch to ON.

- b. Operation of Omni Lock  
If the Omni needle indicates  $5^\circ$  or more from the selected bearing, the airplane will turn until the Directional Gyro heading is within  $30^\circ$  to  $45^\circ$  of the selected bearing. This heading will be maintained until the needle indicates approximately  $5^\circ$ .

At this point the intercept angle will gradually decrease until the needle is centered and the airplane heading is the same as the selected Omni Bearing.

If the intercept angle should exceed  $45^{\circ}$ , this can be reduced and performance improved by use of the Roll Trim Lever located below the TURN knob.

The Directional Gyro that is used in conjunction with Omni Lock will permit any heading change desired up to a full  $180^{\circ}$ .

To compensate for crosswind the airplane will fly at a crab angle with respect to the Directional Gyro Course Card setting and the Omni needle will remain to one side of center up to several degrees, depending on wind velocity and direction.

If it is desired to fly with the Omni needle centered, the D. G. Course Card should be turned to align with the D. G. Heading Card.

When the Autopilot is coupled to COMM-NAV equipment (in lieu of only NAV equipment), the Omni Lock is automatically neutralized whenever the microphone button is depressed. When this occurs, the airplane will maintain the heading set on the D. G. Course Card.

#### NOTE

This Omni Lock is to be used only as an aid in flying the Omni-Directional Navigation Range. It is not to be used without normal pilot cross-reference to the basic navigational instrumentation.

#### 4. LOC mode

##### a. To Engage LOC mode

Tune in Localizer Station

Set Directional Gyro Course Card to published ILS runway heading and select HDG Switch to ON. Engage LOC mode by selecting VOR-LOC Switch to LOC and Autopilot NAV Switch to ON.

##### b. Operation of LOC mode

If LOC needle is off-scale, the airplane will turn until the Directional Gyro heading is within 30° to 45° of Course Card setting. This heading will be maintained until LOC needle begins to move off of its stop. Intercept angle will gradually decrease until LOC needle is centered and aircraft heading is the same as Course Card setting.

To track exact center of localizer beam, D.G. Course Card should be turned to align it with D.G. Heading Card to eliminate effects of crosswind and gyro precession.

When the Autopilot is coupled to COM-NAV equipment (in lieu of only NAV equipment), LOC mode is automatically neutralized whenever microphone button is depressed. Autopilot then reverts to HDG mode (maintains setting of D.G. Course Card) until the microphone button is released.

#### NOTE

Localizer mode of the Autopilot is to be used only as an aid in flying the localizer beam of an ILS. It is not to be used without normal pilot cross-reference to basic navigational instrumentation.

**PERFORMANCE - No change**

Approved:

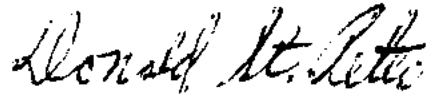

for Chester A. Rembleske  
Beech Aircraft Corporation  
DOA CE-2

**BEECHCRAFT 35-C33, 35-C33A, E33, E33A, E33C,  
F33, F33A, F33C, G33, S35, V35, V35A, V35B, 36,  
A36, AND A36TC LANDPLANES**

**PILOT'S OPERATING HANDBOOK AND  
FAA APPROVED AIRPLANE FLIGHT MANUAL  
SUPPLEMENT  
for the  
LANDING GEAR SAFETY SYSTEM**

**GENERAL**

This document is to be attached to the Pilot's Operating Handbook and FAA Approved Airplane Flight Manual when the airplane is equipped with the Landing Gear Safety System which has been installed in accordance with BEECHCRAFT FAA approved data.

This document supersedes or adds to the Pilot's Operating Handbook and FAA Approved Airplane Flight Manual only where covered in the items contained herein.

**LIMITATIONS**

The landing gear safety system is designed to help prevent "gear-up" landings and premature or inadvertent operation of the landing gear mechanism. The system is to be used as safety backup device only; normal usage of the landing gear position switch is mandatory.

**EMERGENCY PROCEDURES**

In the event of an emergency, automatic extension of the landing gear may be prevented by placing the landing gear safety system switch in the OFF position, thus inactivating the safety system.

**FAA Approved  
Revised: April 1981  
P/N 35-590110-13**

## **NORMAL PROCEDURES**

### **PREFLIGHT CHECK:**

1. Throttle - CLOSED OR RETARDED.
2. Battery master switch - ON
3. Landing gear circuit breaker - either IN or OUT.
4. (Airplanes incorporating the on-off and test function in one switch.)  
Place the ON-OFF-TEST switch in the TEST position. Proper functioning of the automatic landing gear extension portion of the system is indicated by the noise or movement of the solenoid in the landing gear position switch. The ON-OFF-TEST switch returns normally to the ON position unless the pilot places the switch in the OFF position.
5. (Airplanes equipped with on-off and press-to-test switches.)  
Place the ON-OFF switch in the "ON" position and push the PRESS-TO-TEST. Proper functioning of the automatic landing gear extension portion of the system is indicated by the noise or movement of the solenoid in the landing gear position switch. The PRESS-TO-TEST switch will not operate the solenoid unless the on-off switch is in the "ON" position.
6. Landing gear circuit breaker - IN before takeoff.

### **OPERATION**

1. Landing Gear Extension - With the landing gear safety system switch in the ON position the landing gear will be automatically extended when: (1) the airspeed is below approximately 104 kts/120 mph IAS and (2) the engine is

operating at a throttle position corresponding to approximately 18 to 20 inches or less of manifold pressure depending on setting.

2. Landing Gear Retraction - With the landing gear safety system switch in the ON position, the landing gear will not retract unless: (1) the landing gear position switch is in the UP position (2) the airspeed is above approximately 78 kts/90 mph IAS and (3) the engine is operating at a throttle position corresponding to approximately 18 to 20 inches or more of manifold pressure depending on setting.

#### NOTE

If landing gear retraction is desired before the indicated airspeed reaches approximately 78 kts/90 mph, the landing gear safety system must be inactivated by placing the switch in the OFF position, preferably before placing the landing gear position switch in the UP position.

#### PERFORMANCE

No change

Approved:



W. H. Schultz  
Beech Aircraft Corporation  
DOA CE-2

**FAA Approved**  
**Revised: April 1981**  
**P/N 35-590110-13**

**3 of 3**

# BEECHCRAFT LANDPLANES

**35-C33, E33, F33, 35-C33A, E33A, AND F33A  
(SERIALS CE-290 THRU CE-315)**

**PILOT'S OPERATING HANDBOOK AND  
FAA APPROVED AIRPLANE FLIGHT MANUAL  
SUPPLEMENT**

for the

## **FIFTH SEAT INSTALLATION**

### **GENERAL**

This document is to be attached to the Pilot's Operating Handbook and FAA Approved Airplane Flight Manual when the airplane is equipped with a fifth seat installation in accordance with Beech FAA Approved Data.

This document supersedes or adds to the Pilot's Operating Handbook and FAA Approved Airplane Flight Manual only where covered in the items contained herein.

### **LIMITATIONS**

#### **PLACARDS**

*On Baggage Door:*

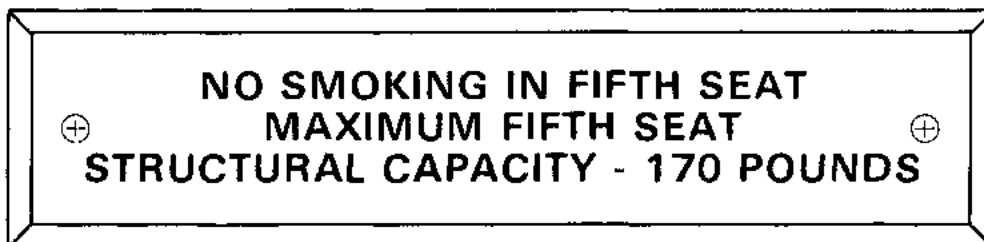

**FAA Approved  
Revised: September 1977  
P/N 33-534033-9**

**EMERGENCY PROCEDURES - No change**

**NORMAL PROCEDURES - No change**

**PERFORMANCE - No change**

Approved:

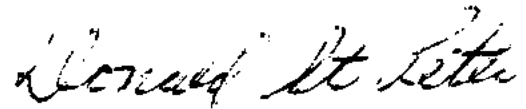

*for* Chester A. Rembleske  
Beech Aircraft Corporation  
DOA CE-2

**BEECHCRAFT LANDPLANE**  
**E33, F33, 35-C33A, E33A,**  
**E33C, F33A, F33C, 36 and A36**

**PILOT'S OPERATING HANDBOOK AND**  
**FAA APPROVED AIRPLANE FLIGHT MANUAL**  
**SUPPLEMENT**

for the

**ELECTROTHERMAL PROPELLER DEICE**  
**(2 and 3 Bladed Propeller)**

**GENERAL**

The information in this supplement is FAA approved material and must be attached to the Pilot's Operating Handbook and FAA Approved Airplane Flight Manual when the airplane is equipped with an Electrothermal Propeller Deice System that has been installed in accordance with BEECHCRAFT FAA approved data, or if the system is installed by kit, in accordance with Beech Kit 35-9001, 35-9003, or 35-9005.

This document supersedes or adds to the Pilot's Operating Handbook and FAA Approved Airplane Flight Manual only where covered in the items contained herein.

**LIMITATIONS**

Do not operate the system unless engine is operating.

**EMERGENCY PROCEDURES**

1. Loss of Alternator
  - a. Propeller Deice Switch - Off

**FAA Approved**  
**Revised: October 1977**  
**P/N 130694**

## 2. Abnormal Reading on Propeller Deice Ammeter

### a. Zero Amps

Check propeller deice switch. If the circuit breaker in the switch has tripped, a wait of approximately 30 seconds is necessary before resetting the switch to the ON position. If ammeter reads 0 and switch has not tripped or if ammeter still reads 0 after the switch has been reset, turn the switch off and consider the propeller deice system inoperative.

### b. Zero to 20 Amps (2 Blade) Zero to 30 Amps (3 Blade)

If propeller deice system ammeter occasionally or regularly indicates less than 20 amps (2 blade), 30 amps (3 blade), operation of the propeller deice system can continue unless serious propeller imbalance results from irregular ice throw-offs.

### c. More than 24 Amps (2 Blade) More than 34 Amps (3 Blade)

If the propeller deice system ammeter occasionally or regularly indicates more than 24 amps (2 blade), 34 amps (3 blade), the system should not be operated unless the need for propeller deice is urgent.

## **NORMAL PROCEDURES**

### **PREFLIGHT**

1. With engine operating, place propeller deice switch in the ON position.

2. Check propeller deice system ammeter for reading of 20 to 24 amperes (2 blade) 30 to 34 amperes (3 blade).
3. Watch ammeter closely for at least two minutes. A small momentary deflection of the needle may be noticed approximately every 30 seconds: This is due to the switching action of the timer and is an indication of normal operation of the system.

#### IN FLIGHT

1. To place the system in operation, move propeller deice switch to the ON position. The system will function automatically until the switch is turned off.

#### CAUTION

The system is not to be operated continuously due to its electrical load.

2. Propeller imbalance may be relieved by varying rpm. Increase rpm briefly and return to desired setting, repeating if necessary.
3. The use of propeller deice is acceptable only if the electrical load is monitored so that the ammeter does not show a discharge.

#### PERFORMANCE - No change

Approved:

*for*   
for Chester A. Rembleske  
Beech Aircraft Corporation  
DOA CE-2

FAA Approved  
Revised: October 1977  
P/N 130694

**BEEHCRAFT Debonair/Bonanza  
35-B33, 35-C33, E33, F33, and G33  
(Serials CD-388 thru CD-1304);  
35-C33A, E33A, and F33A  
(Serials CE-1 thru CE-1013);  
Bonanza E33C and F33C  
(Serials CJ-1 thru CJ-155);  
P35, S35, V35, V35TC, V35A, V35A-TC, V35B, and  
V35B-TC  
(Serials D-6874 thru D-10403);  
36 and A36  
(Serials E-1 thru E-2061);  
and A36TC  
(Serials EA-1 thru EA-272 except EA-242)  
LANDPLANES**

**PILOT'S OPERATING HANDBOOK AND  
FAA APPROVED AIRPLANE FLIGHT MANUAL  
SUPPLEMENT  
for the  
FUEL SELECTOR VALVE  
STOP INSTALLATION  
(BEEHCRAFT SERVICE INSTRUCTIONS NO. 1248)**

**GENERAL**

This document is to be attached to the Pilot's Operating Handbook and FAA Approved Airplane Flight Manual when the airplane is equipped with the Fuel Selector Valve Stop Installation which has been installed in accordance with BEEHCRAFT Service Instructions No. 1248.

This document supersedes or adds to the Pilot's Operating Handbook and FAA Approved Airplane Flight Manual only where covered in the items contained herein.

**FAA Approved  
Issued: March, 1983  
P/N 36-590002-39**

**1 of 4**

## NOTE

This installation is not applicable to airplanes equipped with the Britain wing tip fuel system.

## LIMITATIONS

## PLACARDS

On Fuel Selector Panel:

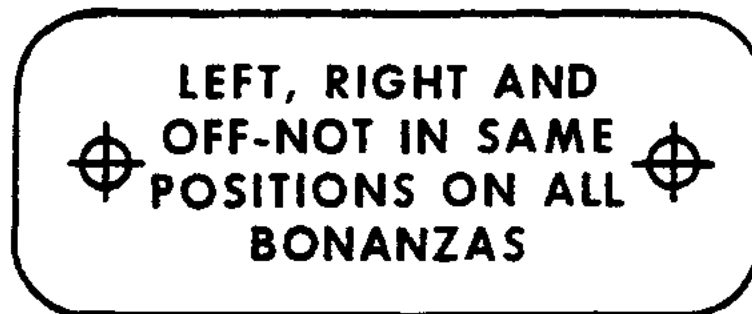

and;



## EMERGENCY PROCEDURES

No Change

## **NORMAL PROCEDURES**

No Change

## **PERFORMANCE**

No Change

## **WEIGHT AND BALANCE**

No Change

## **SYSTEMS DESCRIPTION**

### **FUEL SYSTEM**

#### ***FUEL TANK SELECTION***

The fuel selector valve handle is located forward and to the left of the pilot's seat. Takeoffs and landings should be made using the tank that is more nearly full.

On airplanes equipped with the fuel selector valve stop installation (BEECHCRAFT Service Instructions No. 1248), the pilot is cautioned to observe that the short, pointed end of the handle aligns with the fuel tank position being selected. The tank positions are located on the aft side of the valve. The OFF position is forward and to the left. An OFF position lock-out feature has been added to prevent

inadvertant selection of the OFF position. To select OFF, depress the lock-out stop and rotate the handle to the full clockwise position. Depression of the lock-out stop is not required when moving the handle counterclockwise from OFF to LEFT MAIN or RIGHT MAIN. When selecting the LEFT MAIN or RIGHT MAIN fuel tanks, position handle by sight and by feeling for detent.

If the engine stops because of insufficient fuel, refer to the EMERGENCY PROCEDURES Section for the Air Start procedures.

Approved: *Donald St. Peter*

*for*

W. H. Schultz  
Beech Aircraft Corporation  
DOA CE-2

**BEECHCRAFT SERIES 33,35,36,55,58**

**PILOT'S OPERATING HANDBOOK AND FAA  
APPROVED AIRPLANE FLIGHT MANUAL  
SUPPLEMENT**

**FOR**

**INSIDE CABIN DOOR HANDLE WITH OPEN/  
CLOSED PLACARD**

**THIS SUPPLEMENT IS APPLICABLE TO PILOT'S  
OPERATING HANDBOOKS AND FAA APPROVED  
AIRPLANE FLIGHT MANUALS:**

**(SEE NEXT PAGE FOR APPLICABILITY)**

Airplane Serial Number: \_\_\_\_\_

Airplane Registration Number: \_\_\_\_\_

FAA Approved:



W. H. Schultz  
Beech Aircraft Corporation  
DOA CE-2

**COPYRIGHT © BEECH 1990**

This supplement applies to the following Pilot's Operating Handbooks and FAA Approved Airplane Flight Manuals:

MODEL	PART NUMBER	A/C SERIALS
35-B33	33-590000-17B	All
35-C33, E33, F33	33-590002-9B	All
35-C33A, E33A, E33C	33-590003-7B	All
F33A, F33C	33-590009-13	CE-674 & after, CJ-129 & after
F33A, F33C	33-590009-15	CE-290 thru CE- 673, CJ-26 thru CJ-128
G33	33-590027-3	All
F35	35-590071-13	All
G35	35-590072-9	All
H35	35-590073-15	All
N35, P35	35-590094-7	All
S35-TC	35-590110-3	All
S35	35-590110-11B	All
V35-TC	35-590113-3	All
V35A-TC	35-590116-3	All
V35B-TC	35-590118-23	D-9069 thru D- 9947
V35B	35-590118-29	D-9948 & after
V35, V35A, V35B	35-590118-31B	D-7977 thru D- 9947
A36	36-590002-17	E-927 thru E-2110 except E-1946 & E-2104
36, A36	36-590002-19C	E-1 thru E-926
A36	36-590002-37	E-1946, E-2104, E- 2111 & after
A36-TC	36-590003-3	EA-1 thru EA-272 except EA-242

FAA Approved  
P/N 58-590000-49  
Issued: December, 1990

MODEL	PART NUMBER	A/C SERIALS
B36-TC	36-590006-3	EA-242, EA-273 thru EA-388 except EA-326
B36-TC	36-590006-19	EA-326, EA-389 & after
95-B55B 95-55, 95-A55	55-590000-49 55-590000-65B	All TC-1 thru TC-501 except TC-350 & TC-371
58, 58A	58-590000-21	TH-773 thru TH- 1395 except TH- 1389
58, 58A 58, 58A	58-590000-31B 58-590000-35	TH-1 thru TH-772 TH-1389, TH-1396 thru TH-1471, TH- 1476, TH-1487, TH- 1489, TH-1498
58, 58A	58-590000-39	TH-1472 & after, except TH-1476, TH-1487, TH-1489, TH-1498
E55, E55A 95-C55, 95-C55A, D55, D55A, E55, E55A	96-590010-17 96-590010-29B	TE-1084 & after TC-350, TE-1 thru TE-942, except TE-938
E55, E55A	96-590010-31	TE-938, TE-943 thru TE-1083
E55, E55A	96-590010-37	TE-1197 only
95-B55, 95-B55A	96-590011-17	TC-2003 & after
95-B55, 95-B55A	96-590011-23	TC-1608 thru TC- 2002
95-B55, 95-B55A	96-590011-25	TC-371, TC-502 thru TC-1607
58TC	106-590000-5	TK-1 thru TK-84
58TC, 58TCA	106-590000-19	TK-85 thru TK-150, except TK-147

<b>MODEL</b>	<b>PART NUMBER</b>	<b>A/C SERIALS</b>
58TC, 58TCA	106-590000-21	TK-147, TK-151 & after

# CONTENTS

GENERAL .....	Page 5
LIMITATIONS .....	Page 5
EMERGENCY PROCEDURES .....	Page 6
NORMAL PROCEDURES .....	Page 6
PERFORMANCE .....	Page 6
WEIGHT & BALANCE .....	Page 6
SYSTEMS DESCRIPTION .....	Page 6
HANDLING, SERVICING & MAINTENANCE .....	Page 7

## GENERAL

The information in this supplement is FAA-approved material and must be attached to the Pilot's Operating Handbook and FAA Approved Airplane Flight Manual when the airplane has been modified by installation of the Inside Cabin Door Handle With Open/Closed Placard in accordance with Beech Kit 35-5050.

The information in this supplement supersedes or adds to the basic Pilot's Operating Handbook and FAA Approved Airplane Flight Manual only as set forth below. Users of the manual are advised to always refer to the supplement for possibly superseding information and placarding applicable to operation of the airplane.

## LIMITATIONS

## PLACARDS

*On inside of Cabin Door Adjacent to Door Handle:*

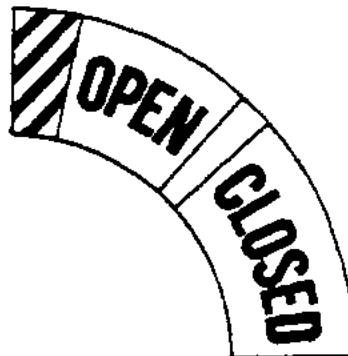

## **EMERGENCY PROCEDURES**

No change.

## **NORMAL PROCEDURES**

### **BEFORE TAKEOFF**

All procedures specified in the Pilot's Operating Handbook and FAA Approved Airplane Flight Manual for the particular airplane shall be completed. In addition, accomplish the following:

- Doors and Windows - SECURE (Check cabin door lock indicator - CLOSED)

### **PERFORMANCE**

No change.

### **WEIGHT AND BALANCE**

No change.

## **SYSTEMS DESCRIPTION**

### **DOORS, WINDOWS AND EXITS**

#### *CABIN DOOR*

The airplane has a conventional cabin door on the forward right side of the fuselage and when closed, the outside cabin door handle is spring loaded to fit into a recess in the door to create a flat aerodynamically clean surface. The door may be locked with a key. To open the door from the outside, lift the handle from its recess and pull until the door opens.

To close the cabin door from the inside, observe that the door handle is in the open position. In this position, the latch handle is free to move approximately one inch in either direction before engagement of the locking mechanism. Then grasp the door and firmly pull the door closed. Rotate the door handle fully counterclockwise into the locked position. Observe that the door handle indicator is in the CLOSED position. When the door is properly locked, the door latch handle is free to move approximately one inch in either direction.

### **NOTE**

When checking the door latch handle, do not move it far enough to engage the door latch release mechanism.

Press firmly outward at the top rear corner of the door. If any movement of the door is detected, completely open the door and close again following the above instructions.

To open the door from the inside, depress the lock button and rotate the handle clockwise.

### **HANDLING, SERVICING, AND MAINTENANCE**

No change.

**SECTION X**  
**SAFETY INFORMATION**  
**TABLE OF CONTENTS**

<i>SUBJECT</i>	<i>PAGE</i>
<b>Introduction</b> .....	10-3
<b>General</b> .....	10-5
Do's .....	10-5
Don'ts .....	10-6
<b>Sources of Information</b> .....	10-7
<b>Pilot's Operating Handbook and FAA Approved</b>	
<b>Airplane Flight Manual</b> .....	10-7
<b>BEECHCRAFT Service Publications</b> .....	10-8
<b>Federal Aviation Regulations</b> .....	10-10
Airworthiness Directives .....	10-10
Airman's Information Manual .....	10-10
Advisory Information .....	10-11
FAA Advisory Circulars .....	10-12
FAA General Aviation News .....	10-15
FAA Accident Prevention Program .....	10-15
Additional Information .....	10-16
<b>General Information on Specific Topics</b> .....	10-17
Maintenance .....	10-17
Hazards of Unapproved Modifications .....	10-19
Flight Planning .....	10-20
Passenger Information Cards .....	10-20
Stowage of Articles .....	10-21
Flight Operations .....	10-21
General .....	10-21
Preflight Inspection .....	10-21
Weight and Balance .....	10-22
Autopilots and Electric Trim Systems .....	10-23
Flutter .....	10-26
Turbulent Weather .....	10-27
Wind Shear .....	10-30
Weather Radar .....	10-30
Mountain Flying .....	10-32
VFR - Low Ceilings .....	10-33
VFR at Night .....	10-33
Vertigo - Disorientation .....	10-34
<b>May, 1994</b>	<b>10-1</b>

**SECTION X**  
**SAFETY INFORMATION**  
**TABLE OF CONTENTS (Continued)**

<i>SUBJECT</i>	<i>PAGE</i>
Stalls, Slow Flight and Training .....	10-36
Spins .....	10-36
Descent .....	10-38
Vortices - Wake Turbulence .....	10-39
Takeoff and Landing Conditions .....	10-40
Medical Facts for Pilots .....	10-40
General .....	10-40
Fatigue .....	10-41
Hypoxia .....	10-41
Hyperventilation .....	10-43
Alcohol .....	10-43
Drugs .....	10-45
Scuba Diving .....	10-45
Carbon Monoxide and Night Vision .....	10-45
Decompression Sickness .....	10-46
<b>A Final Word .....</b>	<b>10-47</b>

## **INTRODUCTION**

Beech Aircraft Corporation has developed this special summary publication of safety information to refresh pilots' and owners' knowledge of safety related subjects. Topics in this publication are dealt with in more detail in FAA Advisory Circulars and other publications pertaining to the subject of safe flying.

The skilled pilot recognizes that safety consciousness is an integral - and never-ending - part of his or her job. Be thoroughly familiar with your airplane. Know its limitations and your own. Maintain your currency, or fly with a qualified instructor until you are current and proficient. Practice emergency procedures at safe altitudes and airspeeds, preferably with a qualified instructor pilot, until the required action can be accomplished without reference to the manual. Periodically review this safety information as part of your recurring training regimen.

BEECHCRAFT airplanes are designed and built to provide you with many years of safe and efficient transportation. By maintaining your BEECHCRAFT properly and flying it prudently you will realize its full potential.

..... Beech Aircraft Corporation

**WARNING**

Because your airplane is a high performance, high speed transportation vehicle, designed for operation in a three-dimensional environment, special safety precautions must be observed to reduce the risk of fatal or serious injuries to the pilot(s) and occupant(s).

It is mandatory that you fully understand the contents of this publication and the other operating and maintenance manuals which accompany the airplane; that FAA requirements for ratings, certifications and review be scrupulously complied with; and that you allow only persons who are properly licensed and rated, and thoroughly familiar with the contents of the Pilot's Operating Handbook and FAA Approved Airplane Flight Manual to operate the airplane.

**IMPROPER OPERATION OR MAINTENANCE OF AN AIRPLANE, NO MATTER HOW WELL BUILT INITIALLY, CAN RESULT IN CONSIDERABLE DAMAGE OR TOTAL DESTRUCTION OF THE AIRPLANE, ALONG WITH SERIOUS OR FATAL INJURIES TO ALL OCCUPANTS.**

## **GENERAL**

As a pilot, you are responsible to yourself and to those who fly with you, to other pilots and their passengers and to people on the ground, to fly wisely and safely.

The following material in this Safety Information publication covers several subjects in limited detail. Here are some condensed Do's and Don'ts.

### **DO'S**

Be thoroughly familiar with your airplane, know its limitations and your own.

Be current in your airplane, or fly with a qualified instructor until you are current. Practice until you are proficient.

Preplan all aspects of your flight - including a proper weather briefing and adequate fuel reserves.

Use services available - weather briefing, inflight weather and Flight Service Station.

Carefully preflight your airplane.

Use the approved checklist.

Have more than enough fuel for takeoff, plus the trip, and an adequate reserve.

Be sure your weight and C.G. are within limits.

Use seatbelts and shoulder harnesses at all times.

Be sure all loose articles and baggage are secured.

Check freedom and proper direction of operation of all controls during preflight inspection.

Maintain the prescribed airspeeds in takeoff, climb, descent, and landing.

Avoid wake turbulence (Vortices).

Preplan fuel and fuel tank management before the actual flight. Utilize auxiliary tanks only in level cruise flight. Take off and land on the fullest main tank, NEVER use auxiliary tanks for takeoff or landing.

Practice emergency procedures at safe altitudes and air-speeds, preferably with a qualified instructor pilot, until the required action can be accomplished without reference to the manual.

Keep your airplane in good mechanical condition.

Stay informed and alert; fly in a sensible manner.

### **DON'TS**

Don't take off with frost, ice or snow on the airplane.

Don't take off with less than minimum recommended fuel, plus adequate reserves, and don't run the tank dry before switching.

Don't fly in a reckless, show-off, or careless manner.

Don't fly into thunderstorms or severe weather.

Don't fly in possible icing conditions.

Don't fly close to mountainous terrain.

Don't apply controls abruptly or with high forces that could exceed design loads of the airplane.

Don't fly into weather conditions that are beyond your ratings or current proficiency.

Don't fly when physically or mentally exhausted or below par.

Don't trust to luck.

## **SOURCES OF INFORMATION**

There is a wealth of information available to the pilot created for the sole purpose of making your flying safer, easier and more efficient. Take advantage of this knowledge and be prepared for an emergency in the event that one should occur.

## **PILOT'S OPERATING HANDBOOK AND FAA APPROVED AIRPLANE FLIGHT MANUAL**

You must be thoroughly familiar with the contents of your operating manuals, placards, and check lists to ensure safe utilization of your airplane. When the airplane was manufactured, it was equipped with one or more of the following: placards, Owner's Manual, FAA Approved Airplane Flight Manual, FAA Approved Airplane Flight Manual Supplements, Pilot's Operating Handbook and FAA Approved Airplane Flight Manual. Beech has revised and reissued many of the early manuals for certain models of airplanes in GAMA Standard Format as Pilot's Operating Handbooks and FAA Approved Airplane Flight Manuals. For simplicity and convenience, all official manuals in various models are referred to as the Pilot's Operating Handbook and FAA Approved Airplane Flight Manual. If the airplane has changed ownership, the Pilot's Operating Handbook and FAA Approved Airplane Flight Manual may have been misplaced or may not be current. Replacement handbooks may be obtained from any BEECHCRAFT Authorized Outlet.

## **BEECHCRAFT SERVICE PUBLICATIONS**

Beech Aircraft Corporation publishes a wide variety of manuals, service letters, service instructions, service bulletins, safety communiques and other publications for the various models of BEECHCRAFT airplanes. Information on how to obtain publications relating to your airplane is contained in BEECHCRAFT Service Bulletin number 2001, entitled "General - BEECHCRAFT Service Publications - What is Available and How to Obtain It."

Beech Aircraft Corporation automatically mails original issues and revisions of BEECHCRAFT Service Bulletins (Mandatory, Recommended and Optional), FAA Approved Airplane Flight Manual Supplements, reissues and revisions of FAA Approved Airplane Flight Manuals, Flight Handbooks, Owners Manuals, Pilot's Operating Manuals and Pilot's Operating Handbooks, and original issues and revisions of BEECHCRAFT Safety Communiques to BEECHCRAFT Owner addresses as listed by the FAA Aircraft Registration Branch List and the BEECHCRAFT International Owner Notification Service List. While this information is distributed by Beech Aircraft Corporation, Beech can not make changes in the name or address furnished by the FAA. The owner must contact the FAA regarding any changes to name or address. Their address is: FAA Aircraft Registration Branch (AAC250) P.O. Box 25082, Oklahoma City, OK 73125, Phone (405) 680-2131.

It is the responsibility of the FAA owner of record to ensure that any mailings from Beech are forwarded to the proper persons. Often the FAA registered owner is a bank or financing company or an individual not in possession of the airplane. Also, when an airplane is sold, there is a lag in processing the change in registration with the FAA. If you are a new owner, contact your BEECHCRAFT Authorized Outlet and ensure your manuals are up to date.

Beech Aircraft Corporation provides a subscription service which provides for direct factory mailing of BEECHCRAFT

publications applicable to a specific serial number airplane. Details concerning the fees and ordering information for this owner subscription service are contained in Service Bulletin number 2001.

For owners who choose not to apply for a Publications Revision Subscription Service, Beech provides a free Owner Notification Service by which owners are notified by post card of BEEHCRAFT manual reissues, revisions and supplements which are being issued applicable to the airplane owned. On receipt of such notification, the owner may obtain the publication through a BEEHCRAFT Authorized Outlet. This notification service is available when requested by the owner. This request may be made by using the owner notification request card furnished with the loose equipment of each airplane at the time of delivery, or by a letter requesting this service, referencing the specific airplane serial number owned. Write to:

Supervisor, Special Services  
Dept. 52  
Beech Aircraft Corporation  
P.O. Box 85  
Wichita, Kansas 67201-0085

From time to time Beech Aircraft Corporation issues BEEHCRAFT Safety Communiques dealing with the safe operation of a specific series of airplanes, or airplanes in general. It is recommended that each owner/operator maintain a current file of these publications. Back issues of BEEHCRAFT Safety Communiques may be obtained without charge by sending a request, including airplane model and serial number, to the Supervisor, Special Services, at the address listed above.

Airworthiness Directives (AD's) are not issued by the manufacturer. They are issued and available from the FAA.

## **FEDERAL AVIATION REGULATIONS**

FAR Part 91, General Operating and Flight Rules, is a document of law governing operation of airplanes and the owner's and pilot's responsibilities. Some of the subjects covered are:

Responsibilities and authority of the pilot-in-command

Certificates required

Liquor and drugs

Flight plans

Preflight action

Fuel requirements

Flight rules

Maintenance, preventive maintenance, alterations, inspection and maintenance records

You, as a pilot, have responsibilities under government regulations. The regulations are designed for your protection and the protection of your passengers and the public. Compliance is mandatory.

## **AIRWORTHINESS DIRECTIVES**

FAR Part 39 specifies that no person may operate a product to which an Airworthiness Directive issued by the FAA applies, except in accordance with the requirements of that Airworthiness Directive.

## **AIRMAN'S INFORMATION MANUAL**

The Airman's Information Manual (AIM) is designed to provide airmen with basic flight information and ATC procedures for use in the national airspace system of the United States. It also contains items of interest to pilots concerning health and medical facts, factors affecting flight safety, a pilot/controller glossary of terms in the Air Traffic Control

system, information on safety, and accident/hazard reporting. It is revised at six-month intervals and can be purchased from the Superintendent of Documents, U.S. Government Printing Office, Washington, D.C. 20402.

This document contains a wealth of pilot information. Among the subjects are:

- Controlled Airspace
- Emergency Procedures
- Services Available to Pilots
- Weather and Icing
- Radio Phraseology and Technique
- Mountain Flying
- Airport Operations
- Wake Turbulence - Vortices
- Clearances and Separations
- Medical Facts for Pilots
- Preflight
- Bird Hazards
- Departures - IFR
- Good Operating Practices
- En route - IFR
- Airport Location Directory
- Arrival - IFR

All pilots must be thoroughly familiar with and use the information in the AIM.

## **ADVISORY INFORMATION**

NOTAMS (Notices to Airmen) are documents that have information of a time-critical nature that would affect a pilot's decision to make a flight; for example, an airport closed, terminal radar out of service, or enroute navigational aids out of service.

## **FAA ADVISORY CIRCULARS**

The FAA issues Advisory Circulars to inform the aviation public in a systematic way of nonregulatory material of interest. Advisory Circulars contain a wealth of information with which the prudent pilot should be familiar. A complete list of current FAA Advisory Circulars is published in AC 00-2, which lists Advisory Circulars that are for sale, as well as those distributed free of charge by the FAA, and provides ordering information. Many Advisory Circulars which are for sale can be purchased locally in aviation bookstores or at FBO's. These documents are subject to periodic revision. Be certain the Advisory Circular you are using is the latest revision available. Some of the Advisory Circulars of interest to pilots are:

- |               |   |
|---------------|---|
| <b>*00-6</b>  | <b>Aviation Weather</b>   |
| <b>00-24</b>  | <b>Thunderstorms</b>  |
| <b>00-30</b>  | <b>Rules of Thumb for Avoiding or Minimizing Encounters with Clear Air Turbulence</b>   |
| <b>*00-45</b> | <b>Aviation Weather Services</b>  |
| <b>00-46</b>  | <b>Aviation Safety Reporting Program</b>  |
| <b>20-5</b>   | <b>Plane Sense</b>  |
| <b>20-32</b>  | <b>Carbon Monoxide (CO) Contamination in Aircraft - Detection and Prevention</b>  |
| <b>20-35</b>  | <b>Tie-Down Sense</b>   |
| <b>20-43</b>  | <b>Aircraft Fuel Control</b>  |
| <b>20-105</b> | <b>Engine Power-Loss Accident Prevention</b>  |
| <b>20-113</b> | <b>Pilot Precautions and Procedures to be Taken in Preventing Aircraft Reciprocating Engine Induction System &amp; Fuel System Icing Problems</b> |
| <b>20-125</b> | <b>Water in Aviation Fuel</b>   |

- 21-4** Special Flight Permits for Operation of Overweight Aircraft
- 43-9** Maintenance Records: General Aviation Aircraft
- 43-12** Preventive Maintenance
- 60-4** Pilot's Spatial Disorientation
- 60-6** Airplane Flight Manuals (AFM), Approved Manual Materials, Markings and Placards - Airplanes
- 60-12** Availability of Industry-Developed Guidelines for the Conduct of the Biennial Flight Review
- 60-13** The Accident Prevention Counselor Program
- \*61-9** Pilot Transition Courses for Complex Single-Engine and Light Twin-Engine Airplanes
- \*61-21** Flight Training Handbook
- \*61-23** Pilot's Handbook of Aeronautical Knowledge
- \*61-27** Instrument Flying Handbook
- 61-67** Hazards Associated with Spins in Airplanes Prohibited from Intentional Spinning.
- 61-84** Role of Preflight Preparation
- \*67-2** Medical Handbook for Pilots
- 90-23** Aircraft Wake Turbulence
- 90-42** Traffic Advisory Practices at Nontower Airports

**Section X  
Safety Information**

**Beechcraft  
Single Engine (Piston)**

- 90-48** Pilot's Role in Collision Avoidance
- 90-66** Recommended Standard Traffic Patterns for Airplane Operations at Uncontrolled Airports
- 90-85** Severe Weather Avoidance Plan (SWAP)
- 91-6** Water, Slush and Snow on the Runway
- 91-13** Cold Weather Operation of Aircraft
- \*91-23** Pilot's Weight and Balance Handbook
- 91-26** Maintenance and Handling of Air Driven Gyroscopic Instruments
- 91-33** Use of Alternate Grades of Aviation Gasoline for Grade 80/87 and Use of Automotive Gasoline
- 91-35** Noise, Hearing Damage, and Fatigue in General Aviation Pilots
- 91-43** Unreliable Airspeed Indications
- 91-44** Operational and Maintenance Practices for Emergency Locator Transmitters and Receivers
- 91-46** Gyroscopic Instruments - Good Operating Practices
- 91-50** Importance of Transponder Operations and Altitude Reporting
- 91-51** Airplane Deice and Anti-ice Systems
- 91-59** Inspection and Care of General Aviation Aircraft Exhaust Systems
- 91-65** Use of Shoulder Harness in Passenger Seats

**103-4** Hazards Associated with Sublimation of Solid Carbon Dioxide (Dry Ice) Aboard Aircraft

**210-5A** Military Flying Activities

**\* For Sale**

## **FAA GENERAL AVIATION NEWS**

FAA General Aviation News is published by the FAA in the interest of flight safety. The magazine is designed to promote safety in the air by calling the attention of general aviation airmen to current technical, regulatory and procedural matters affecting the safe operation of airplanes. FAA General Aviation News is sold on subscription by the Superintendent of Documents, Government Printing Office, Washington D.C., 20402.

## **FAA ACCIDENT PREVENTION PROGRAM**

The FAA assigns accident prevention specialists to each Flight Standards and General Aviation District Office to organize accident prevention program activities. In addition, there are over 3,000 volunteer airmen serving as accident prevention counselors, sharing their technical expertise and professional knowledge with the general aviation community. The FAA conducts seminars and workshops, and distributes invaluable safety information under this program.

Usually the airport manager, the FAA Flight Service Station (FSS), or Fixed Base Operator (FBO), will have a list of accident prevention counselors and their phone numbers available. All Flight Standards and General Aviation District Offices have a list of the counselors serving the District.

Before flying over unfamiliar territory, such as mountainous terrain or desert areas, it is advisable for transient pilots to consult with local counselors. They will be familiar with the

more desirable routes, the wind and weather conditions, and the service and emergency landing areas that are available along the way. They can also offer advice on the type of emergency equipment you should be carrying.

## **ADDITIONAL INFORMATION**

The National Transportation Safety Board and the Federal Aviation Administration periodically issue, in greater detail, general aviation pamphlets concerning aviation safety. FAA Regional Offices also publish material under the FAA General Aviation Accident Prevention Program. These can be obtained at FAA Offices, Weather Stations, Flight Service Stations or Airport Facilities. Some of these are titled:

12 Golden Rules for Pilots

Weather or Not

Disorientation

Plane Sense

Weather Info Guide for Pilots

Wake Turbulence

Don't Trust to Luck, Trust to Safety

Rain, Fog, Snow

Thunderstorm - TRW

Icing

Pilot's Weather Briefing Guide

Thunderstorms Don't Flirt ... Skirt 'em

IFR-VFR - Either Way Disorientation Can Be Fatal

IFR Pilot Exam-O-Grams

VFR Pilot Exam-O-Grams

Tips on Engine Operation in Small General Aviation Aircraft

Estimating Inflight Visibility

Is the Aircraft Ready for Flight

Tips on Mountain Flying

Tips on Desert Flying

Always Leave Yourself An Out

Safety Guide for Private Aircraft Owners  
Tips on How to Use the Flight Planner  
Tips on the Use of Ailerons and Rudder  
Some Hard Facts About Soft Landings  
Propeller Operation and Care  
Torque "What it Means to the Pilot"  
Weight and Balance. An Important Safety Consideration for Pilots

## **GENERAL INFORMATION ON SPECIFIC TOPICS**

### **MAINTENANCE**

Safety of flight begins with a well maintained airplane. Make it a habit to keep your airplane and all its equipment in air-worthy condition. Keep a "squawk list" on board, and see that all discrepancies, however minor, are noted and promptly corrected.

Schedule your maintenance regularly, and have your airplane serviced by a reputable organization. Be suspicious of bargain prices for maintenance, repair and inspections.

It is the responsibility of the owner and the operator to assure that the airplane is maintained in an airworthy condition and that proper maintenance records are kept.

Use only genuine BEEHCRAFT or BEEHCRAFT approved parts obtained from BEEHCRAFT approved sources, in connection with the maintenance and repair of Beech airplanes.

Genuine BEEHCRAFT parts are produced and inspected under rigorous procedures to insure airworthiness and suitability for use in Beech airplane applications. Parts purchased from sources other than BEEHCRAFT, even though outwardly identical in appearance, may not have had

the required tests and inspections performed, may be different in fabrication techniques and materials, and may be dangerous when installed in an airplane.

Salvaged airplane parts, reworked parts obtained from non-BEECHCRAFT approved sources or parts, components, or structural assemblies, the service history of which is unknown or cannot be authenticated, may have been subjected to unacceptable stresses or temperatures or have other hidden damage not discernible through routine visual or usual nondestructive testing techniques. This may render the part, component, or structural assembly, even though originally manufactured by BEECHCRAFT, unsuitable and unsafe for airplane use.

BEECHCRAFT expressly disclaims any responsibility for malfunctions, failures, damage or injury caused by use of non-BEECHCRAFT parts.

Airplanes operated for Air Taxi or other than normal operation, and airplanes operated in humid tropics, or cold and damp climates, etc., may need more frequent inspections for wear, corrosion and/or lack of lubrication. In these areas, periodic inspections should be performed until the operator can set his own inspection periods based on experience.

## **NOTE**

The required periods do not constitute a guarantee that the item will reach the period without malfunction, as the aforementioned factors cannot be controlled by the manufacturer.

Corrosion and its effects must be treated at the earliest possible opportunity. A clean, dry surface is virtually immune to corrosion. Make sure that all drain holes remain unobstructed. Protective films and sealants help to keep corrosive agents from contacting metallic surfaces. Corrosion

inspections should be made most frequently under high-corrosion-risk operating conditions, such as in areas of excessive airborne salt concentrations (e.g., near the sea) and in high-humidity areas (e.g., tropical regions).

If you have purchased a used airplane, have your mechanic inspect the airplane registration records, logbooks and maintenance records carefully. An unexplained period of time for which the airplane has been out of service, or unexplained significant repairs may well indicate the airplane has been seriously damaged in a prior accident. Have your mechanics inspect a used airplane carefully. Take the time to ensure that you really know what you are buying when you buy a used airplane.

## **HAZARDS OF UNAPPROVED MODIFICATIONS**

Many airplane modifications are approved under Supplemental Type Certificates (STC's). Before installing an STC on your airplane, check to make sure that the STC does not conflict with other STC's that have already been installed. Because approval of an STC is obtained by the individual STC holder based upon modification of the original type design, it is possible for STC's to interfere with each other when both are installed. Never install an unapproved modification of any type, however innocent the apparent modification may seem. Always obtain proper FAA approval.

Airplane owners and maintenance personnel are particularly cautioned not to make attachments to, or otherwise modify, seats from original certification without approval from the FAA Engineering and Manufacturing District Office having original certification responsibility for that make and model.

Any unapproved attachment or modification to seat structure may increase load factors and metal stress which could cause failure of seat structure at a lesser "G" force than exhibited for original certification.

Examples of unauthorized attachments found are drilling holes in seat tubing to attach fire extinguishers and drilling holes to attach approach plate book bins to seats.

## **FLIGHT PLANNING**

FAR Part 91 requires that each pilot in command, before beginning a flight, familiarize himself with all available information concerning that flight.

Obtain a current and complete preflight briefing. This should consist of local, enroute and destination weather and enroute navaid information. Enroute terrain and obstructions, alternate airports, airport runways active, length of runways, and takeoff and landing distances for the airplane for conditions expected should be known.

The prudent pilot will review his planned enroute track and stations and make a list for quick reference. It is strongly recommended a flight plan be filed with Flight Service Stations, even though the flight may be VFR. Also, advise Flight Service Stations of changes or delays of one hour or more and remember to close the flight plan at destination.

The pilot must be completely familiar with the performance of the airplane and performance data in the Pilot's Operating Handbook and FAA Approved Airplane Flight Manual. The resultant effect of temperature and pressure altitude must be taken into account in performance if not accounted for on the charts. An applicable FAA Approved Airplane Flight Manual must be aboard the airplane at all times and include the weight and balance forms and equipment list.

## **PASSENGER INFORMATION CARDS**

Beech has available, for most current production airplanes, passenger information cards which contain important information on the proper use of restraint systems, oxygen

masks, emergency exits and emergency bracing procedures. Passenger information cards may be obtained at any BEECHCRAFT Authorized Outlet. A pilot should not only be familiar with the information contained in the cards, but should always, prior to flight, inform the passengers of the information contained in the information cards. The pilot should orally brief the passengers on the proper use of restraint systems, doors and emergency exits, and other emergency procedures, as required by Part 91 of the FAR's.

## **STOWAGE OF ARTICLES**

The space between the seat pan and the floor is utilized to provide space for seat displacement. If hard, solid objects are stored beneath seats, the energy absorbing feature is lost and severe spinal injuries can occur to occupants.

Prior to flight, pilots should insure that articles are not stowed beneath seats that would restrict seat pan energy absorption or penetrate the seat in event of a high vertical velocity accident.

## **FLIGHT OPERATIONS**

### ***GENERAL***

The pilot **MUST** be thoroughly familiar with **ALL INFORMATION** published by the manufacturer concerning the airplane, and is required by law to operate the airplane in accordance with the FAA Approved Airplane Flight Manual and placards installed.

### ***PREFLIGHT INSPECTION***

In addition to maintenance inspections and preflight information required by FAR Part 91, a complete, careful preflight inspection is imperative.

Each airplane has a checklist for the preflight inspection which must be followed. **USE THE CHECKLIST.**

### ***WEIGHT AND BALANCE***

Maintaining center of gravity within the approved envelope throughout the planned flight is an important safety consideration.

The airplane must be loaded so as not to exceed the weight and center of gravity (C.G.) limitations. Airplanes that are loaded above the maximum takeoff or landing weight limitations will have an overall lower level of performance compared to that shown in the Performance section of the Pilot's Operating Handbook and FAA Approved Airplane Flight Manual. If loaded above maximum takeoff weight, takeoff distance and the landing distance will be longer than that shown in the Performance section; the stalling speed will be higher, rate of climb, the cruising speed, and the range of the airplane at any level of fuel will all be lower than shown in the Performance section.

If an airplane is loaded so that the C.G. is forward of the forward limit, it will require additional control movements for maneuvering the airplane with correspondingly higher control forces. The pilot may have difficulty during takeoff and landing because of the elevator control limits.

If an airplane is loaded aft of the aft C.G. limitation, the pilot will experience a lower level of stability. Airplane characteristics that indicate a lower stability level are; lower control forces, difficulty in trimming the airplane, lower control forces for maneuvering with attendant danger of structural overload, decayed stall characteristics, and a lower level of lateral-directional damping.

Ensure that all cargo and baggage is properly secured before takeoff. A sudden shift in balance at rotation can cause controllability problems.

## ***AUTOPILOTS AND ELECTRIC TRIM SYSTEMS***

Because there are several different models of autopilots and electric trim systems installed in Beech airplanes and different installations and switch positions are possible from airplane to airplane, it is essential that every owner/operator review his Airplane Flight Manual (AFM) Supplements and ensure that the supplements properly describe the autopilot and trim installations on his specific airplane. Each pilot, prior to flight, must be fully aware of the proper procedures for operation, and particularly disengagement, for the system as installed.

In addition to ensuring compliance with the autopilot manufacturer's maintenance requirements, all owners/operators should thoroughly familiarize themselves with the operation, function and procedures described in the Airplane Flight Manual Supplements. Ensure a full understanding of the methods of engagement and disengagement of the autopilot and trim systems.

Compare the descriptions and procedures contained in the Supplements to the actual installation in the airplane to ensure that the supplement accurately describes your installation. Test that all buttons, switches and circuit breakers function as described in the Supplements. If they do not function as described, have the system repaired by a qualified service agency. If field service advice or assistance is necessary, contact Beech Aircraft Corporation, Customer Support Department.

As stated in all AFM Supplements for autopilot systems and trim systems installed on Beech airplanes, the preflight check must be conducted before every flight. The preflight check assures not only that the systems and all of their features are operating properly, but also that the pilot, before flight, is familiar with the proper means of engagement and disengagement of the autopilot and trim system.

Autopilot Airplane Flight Manual Supplements caution against trying to override the autopilot system during flight without disengaging the autopilot because the autopilot will continue to trim the airplane and oppose the pilot's actions. This could result in a severely out of trim condition. This is a basic feature of all autopilots with electric trim follow-up.

Do not try to manually override the autopilot during flight.

**IN CASE OF EMERGENCY, YOU CAN OVERPOWER THE AUTOPILOT TO CORRECT THE ATTITUDE, BUT THE AUTOPILOT AND ELECTRIC TRIM MUST THEN IMMEDIATELY BE DISENGAGED.**

It is often difficult to distinguish an autopilot malfunction from an electric trim system malfunction. The safest course is to deactivate both. Do not re-engage either system until after you have safely landed. Then have the systems checked by a qualified service facility prior to further flight.

Depending upon the installation on your airplane, the following additional methods may be available to disengage the autopilot or electric trim in the event that the autopilot or electric trim does not disengage utilizing the disengage methods specified in the Supplements.

**CAUTION**

Transient control forces may occur when the autopilot is disengaged.

1. Turn off the autopilot master switch, if installed.
2. Pull the autopilot and trim circuit breaker(s) or turn off the autopilot switch breaker, if installed.
3. Turn off the RADIO MASTER SWITCH, if installed, and if the autopilot system and the trim system are wired through this switch.

**CAUTION**

Radios, including VHF COMM are also disconnected when the radio master switch is off.

4. Turn off the ELECTRIC MASTER SWITCH.

**WARNING**

Almost all electrically powered systems will be inoperative. Consult the AFM for further information.

5. Push the GA switch on throttle grip, if installed (depending upon the autopilot system).
6. Push TEST EACH FLT switch on the autopilot controller, if installed.

**NOTE**

After the autopilot is positively disengaged, it may be necessary to restore other electrical functions. Be sure when the master switches are turned on that the autopilot does not re-engage.

The above ways may or may not be available on your autopilot. It is essential that you read your airplane's AFM SUPPLEMENT for your autopilot system and check each function and operation on your system.

The engagement of the autopilot must be done in accordance with the instructions and procedures contained in the AFM SUPPLEMENT.

Particular attention must be paid to the autopilot settings prior to engagement. If you attempt to engage the autopilot when the airplane is out of trim, a large attitude change may occur.

**IT IS ESSENTIAL THAT THE PROCEDURES SET FORTH IN THE APPROVED AFM SUPPLEMENTS FOR YOUR SPECIFIC INSTALLATION BE FOLLOWED BEFORE ENGAGING THE AUTOPILOT.**

### ***FLUTTER***

Flutter is a phenomenon that can occur when an aerodynamic surface begins vibrating. The energy to sustain the vibration is derived from airflow over the surface. The amplitude of the vibration can (1) decrease, if airspeed is reduced; (2) remain constant, if airspeed is held constant and no failures occur; or (3) increase to the point of self-destruction, especially if airspeed is high and/or is allowed to increase. Flutter can lead to an in-flight break up of the airplane. Airplanes are designed so that flutter will not occur in the normal operating envelope of the airplane as long as the airplane is properly maintained. In the case of any airplane, decreasing the damping and stiffness of the structure or increasing the trailing edge weight of control surfaces will tend to cause flutter. If a combination of those factors is sufficient, flutter can occur within the normal operating envelope.

Owners and operators of airplanes have the primary responsibility for maintaining their airplanes. To fulfill that responsibility, it is imperative that all airplanes receive a thorough preflight inspection. Improper tension on the control cables or any other loose condition in the flight control system can also cause or contribute to flutter. Pilot's should pay particular attention to control surface attachment hardware including tab pushrod attachment during preflight inspection. Looseness of fixed surfaces or movement of control surfaces other than in the normal direction of travel should be

rectified before flight. Further, owners should take their airplanes to mechanics who have access to current technical publications and prior experience in properly maintaining that make and model of airplane. The owner should make certain that control cable tension inspections are performed as outlined in the applicable Beech Inspection Guide. Worn control surface attachment hardware must be replaced. Any repainting or repair of a moveable control surface will require a verification of the control surface balance before the airplane is returned to service. Control surface drain holes must be open to prevent freezing of accumulated moisture, which could create an increased trailing-edge-heavy control surface and flutter.

If an excessive vibration, particularly in the control column and rudder pedals, is encountered in flight, this may be the onset of flutter and the procedure to follow is:

1. IMMEDIATELY REDUCE AIRSPEED (lower the landing gear if necessary).
2. RESTRAIN THE CONTROLS OF THE AIRPLANE UNTIL THE VIBRATION CEASES.
3. FLY AT THE REDUCED AIRSPEED AND LAND AT THE NEAREST SUITABLE AIRPORT.
4. HAVE THE AIRPLANE INSPECTED FOR AIRFRAME DAMAGE, CONTROL SURFACE ATTACHING HARDWARE CONDITION/SECURITY, TRIM TAB FREE PLAY, PROPER CONTROL CABLE TENSION, AND CONTROL SURFACE BALANCE BY ANOTHER MECHANIC WHO IS FULLY QUALIFIED.

### ***TURBULENT WEATHER***

A complete and current weather briefing is a requirement for a safe trip.

Updating of weather information enroute is also essential. The wise pilot knows that weather conditions can change

quickly, and treats weather forecasting as professional advice, rather than an absolute fact. He obtains all the advice he can, but stays alert to any sign or report of changing conditions.

Plan the flight to avoid areas of reported severe turbulence. It is not always possible to detect individual storm areas or find the in-between clear areas.

The National Weather Service classifies turbulence as follows:

<b>Class of Turbulence</b>	<b>Effect</b>
<b>Extreme</b>	Airplane is violently tossed about and is practically impossible to control. May cause structural damage.
<b>Severe</b>	Airplane may be momentarily out of control. Occupants are thrown violently against the belts and back into the seat. Unsecured objects are tossed about.
<b>Moderate</b>	Occupants require seat belts and occasionally are thrown against the belt. Unsecured objects move about.
<b>Light</b>	Occupants may be required to use seat belts, but objects in the airplane remain at rest.

Thunderstorms, squall lines and violent turbulence should be regarded as extremely dangerous and must be avoided. Hail and tornadic wind velocities can be encountered in thunderstorms that can destroy any airplane, just as tornadoes destroy nearly everything in their path on the ground.

Thunderstorms also pose the possibility of a lightning strike on an airplane. Any structure or equipment which shows evidence of a lightning strike, or of being subjected to a high

current flow due to a strike, or is a suspected part of a lightning strike path through the airplane should be thoroughly inspected and any damage repaired prior to additional flight.

A roll cloud ahead of a squall line or thunderstorm is visible evidence of extreme turbulence; however, the absence of a roll cloud should not be interpreted as denoting that severe turbulence is not present.

Even though flight in severe turbulence must be avoided, flight in turbulent air may be encountered unexpectedly under certain conditions.

The following recommendations should be observed for airplane operation in turbulent air:

Flying through turbulent air presents two basic problems, the answer to both of which is proper airspeed. On one hand, if you maintain an excessive airspeed, you run the risk of structural damage or failure; on the other hand, if your airspeed is too low, you may stall.

If turbulence is encountered, reduce speed to the turbulent air penetration speed, if given, or to the maneuvering speed, which is listed in the Limitations section of the Pilot's Operating Handbook and FAA Approved Airplane Flight Manual. These speeds give the best assurance of avoiding excessive stress loads, and at the same time provide the proper margin against inadvertent stalls due to gusts.

Beware of overcontrolling in an attempt to correct for changes in attitude; applying control pressure abruptly will build up G-forces rapidly and could cause structural damage or even failure. You should watch particularly your angle of bank, making turns as wide and shallow as possible. Be equally cautious in applying forward or back pressure to keep the airplane level. Maintain straight and level attitude in either up or down drafts. Use trim sparingly to avoid being

grossly out of trim as the vertical air columns change velocity and direction. If necessary to avoid excessive airspeeds, lower the landing gear.

### ***WIND SHEAR***

Wind shears are rapid, localized changes in wind direction, which can occur vertically as well as horizontally. Wind shear can be very dangerous to all airplanes, large and small, particularly on approach to landing when airspeeds are slow.

A horizontal wind shear is a sudden change in wind direction or speed that can, for example, transform a headwind into a tailwind, producing a sudden decrease in indicated airspeed because of the inertia of the airplane. A vertical wind shear, is a sudden updraft or downdraft. Microbursts are intense, highly localized severe downdrafts.

The prediction of wind shears is far from an exact science. Monitor your airspeed carefully when flying near storms, particularly on approach. Be mentally prepared to add power and go around at the first indication that a wind shear is being encountered.

### ***WEATHER RADAR***

Airborne weather avoidance radar is, as its name implies, for avoiding severe weather--not for penetrating it. Whether to fly into an area of radar echoes depends on echo intensity, spacing between the echoes, and the capabilities of you and your airplane. Remember that weather radar detects only precipitation drops; it does not detect turbulence. Therefore, the radar scope provides no assurance of avoiding turbulence. The radar scope also does not provide assurance of avoiding instrument weather due to clouds and fog. Your scope may be clear between intense echoes; this clear area does not necessarily mean you can fly between the storms and maintain visual sighting of them.

Thunderstorms build and dissipate rapidly. Therefore, do not attempt to plan a course between echoes using ground based radar. The best use of ground radar information is to isolate general areas and coverage of echoes. You must avoid individual storms from in-flight observations either by visual sighting or by airborne radar. It is better to avoid the whole thunderstorm area than to detour around individual storms unless they are scattered.

Remember that while hail always gives a radar echo, it may fall several miles from the nearest visible cloud and hazardous turbulence may extend to as much as 20 miles from the echo edge. Avoid intense or extreme level echoes by at least 20 miles; that is, such echoes should be separated by at least 40 miles before you fly between them. With weaker echoes you can reduce the distance by which you avoid them.

Above all, remember this: never regard any thunderstorm lightly. Even when radar observers report the echoes are of light intensity, avoiding thunderstorms is the best policy. The following are some do's and don'ts of thunderstorm avoidance:

1. Don't land or take off in the face of an approaching thunderstorm. A sudden gust front of low level turbulence could cause loss of control.
2. Don't attempt to fly under a thunderstorm even if you can see through to the other side. Turbulence and wind shear under the storm could be disastrous.
3. Don't fly without airborne radar into a cloud mass containing scattered embedded thunderstorms. Embedded thunderstorms usually can not be visually circumnavigated.
4. Don't trust visual appearance to be a reliable indicator of the turbulence inside a thunderstorm.

5. Do avoid by at least 20 miles any thunderstorm identified as severe or giving an intense radar echo. This is especially true under the anvil of a large cumulonimbus.
6. Do circumnavigate the entire area if the area has 6/10 or greater thunderstorm coverage.
7. Do remember that vivid and frequent lightning indicates the probability of a severe thunderstorm.
8. Do regard as extremely hazardous any thunderstorm with tops 35,000 feet or higher, whether the top is visually sighted or determined by radar.

If you cannot avoid penetrating a thunderstorm, the following are some do's BEFORE entering the storm:

9. Tighten your safety belt, put on your shoulder harness, and secure all loose objects.
10. Plan and hold your course to take you through the storm in minimum time.
11. To avoid the most critical icing, establish a penetration altitude below the freezing level or above the level of  $-15^{\circ}\text{C}$ .
12. Verify that pitot heat is on and turn on carburetor heat or engine anti-ice. Icing can be rapid at any altitude and cause almost instantaneous power failure and/or loss of airspeed indication.

### ***MOUNTAIN FLYING***

Pilots flying in mountainous areas should inform themselves of all aspects of mountain flying, including the effects of topographic features on weather conditions. Many good articles have been published, and a synopsis of mountain flying operations is included in the FAA Airman's Information Manual, Part 1.

Avoid flight at low altitudes over mountainous terrain, particularly near the lee slopes. If the wind velocity near the

level of the ridge is in excess of 25 knots and approximately perpendicular to the ridge, mountain wave conditions are likely over and near the lee slopes. If the wind velocity at the level of the ridge exceeds 50 knots, a strong mountain wave is probable with extreme up and down drafts and severe turbulence. The worst turbulence will be encountered in and below the rotor zone, which is usually 8 to 10 miles downwind from the ridge. This zone is sometimes characterized by the presence of "roll clouds" if sufficient moisture is present; altocumulus standing lenticular clouds are also visible signs that a mountain wave exists, but their presence is likewise dependent on moisture. Mountain wave turbulence can, of course, occur in dry air and the absence of such clouds should not be taken as assurance that mountain wave turbulence will not be encountered. A mountain wave downdraft may exceed the climb capability of your airplane. Avoid mountain wave downdrafts.

### ***VFR - LOW CEILINGS***

If you are not instrument rated, do not attempt "VFR on Top" or "Special VFR" flight or clearances. Being caught above a solid cloud layer when an emergency descent is required (or at destination) is an extremely hazardous position for the VFR pilot. Accepting a clearance out of airport control zones with no minimum ceiling and one-mile visibility as permitted with "Special VFR" is a foolish practice for the VFR pilot.

Avoid areas of low ceilings and restricted visibility unless you are instrument rated and proficient and have an instrument equipped airplane. Then proceed with caution and with planned alternates.

### ***VFR AT NIGHT***

When flying VFR at night, in addition to the altitude appropriate for the direction of flight, pilots should maintain a safe minimum altitude as dictated by terrain, obstacles such as

TV towers, or communities in the area flown. This is especially true in mountainous terrain, where there is usually very little ground reference. Minimum clearance is 2,000 feet above the highest obstacle enroute. Do not depend on your ability to see obstacles in time to miss them. Flight on dark nights over sparsely populated country can be the same as IFR, and must be avoided by inexperienced or non-IFR rated pilots.

### ***VERTIGO - DISORIENTATION***

Disorientation can occur in a variety of ways. During flight, inner ear balancing mechanisms are subjected to varied forces not normally experienced on the ground. This, combined with loss of outside visual reference, can cause vertigo. False interpretations (illusions) result, and may confuse the pilot's conception of the attitude and position of his airplane.

Under VFR conditions, the visual sense, using the horizon as a reference, can override the illusions. Under low visibility conditions (night, fog, clouds, haze, etc.) the illusions predominate. Only through awareness of these illusions, and proficiency in instrument flight procedures, can an airplane be operated safely in a low visibility environment.

Flying in fog, dense haze or dust, cloud banks, or very low visibility, with strobe lights or rotating beacons turned on can contribute to vertigo. They should be turned off in these conditions, particularly at night.

All pilots should check the weather and use good judgment in planning flights. The VFR pilot should use extra caution in avoiding low visibility conditions.

Motion sickness often precedes or accompanies disorientation and may further jeopardize the flight.

Disorientation in low visibility conditions is not limited to VFR pilots. Although IFR pilots are trained to look at their instruments to gain an artificial visual reference as a replacement for the loss of a visual horizon, they do not always do so. This can happen when the pilot's physical condition will not permit him to concentrate on his instruments; when the pilot is not proficient in flying instrument conditions in the airplane he is flying; or, when the pilot's work load of flying by reference to his instruments is augmented by such factors as turbulence. Even an instrument rated pilot encountering instrument conditions, intentional or unintentional, should ask himself whether or not he is sufficiently alert and proficient in the airplane he is flying, to fly under low visibility conditions and in the turbulence anticipated or encountered.

If any doubt exists, the flight should not be made or it should be discontinued as soon as possible.

The result of vertigo is loss of control of the airplane. If the loss of control is sustained, it will result in an excessive speed accident. Excessive speed accidents occur in one of two manners, either as an inflight airframe separation or as a high speed ground impact; and they are fatal accidents in either case. All airplanes are subject to this form of accident.

For years, Beech Pilot's Operating Handbooks and FAA Approved Airplane Flight Manuals have contained instructions that the landing gear should be extended in any circumstance in which the pilot encounters IFR conditions which approach the limits of his capability or his ratings. Lowering the gear in IFR conditions or flight into heavy or severe turbulence, tends to stabilize the airplane, assists in maintaining proper airspeed, and will substantially reduce the possibility of reaching excessive airspeeds with catastrophic consequences, even where loss of control is experienced.

Excessive speed accidents occur at airspeeds greatly in excess of two operating limitations which are specified in the

manuals: Maximum maneuvering speed and the "red line" or "never exceed" speed. Such speed limits are set to protect the structure of an airplane. For example, flight controls are designed to be used to their fullest extent only below the airplane's maximum maneuvering speed. As a result, the control surfaces should never be suddenly or fully deflected above maximum maneuvering speed. Turbulence penetration should not be performed above that speed. The accidents we are discussing here occur at airspeeds greatly in excess of these limitations. No airplane should ever be flown beyond its FAA approved operating limitations.

### ***STALLS, SLOW FLIGHT AND TRAINING***

The stall warning system must be kept operational at all times and must not be deactivated by interruption of circuits, circuit breakers, or fuses. Compliance with this requirement is especially important in all high performance single engine airplanes during simulated engine-out practice or stall demonstrations, because the stall speed is critical in all low-speed operation of airplanes.

Training should be accomplished under the supervision of a qualified instructor-pilot, with careful reference to the applicable sections of the FAA Practical Test Standards and FAA Pilot Transition Courses for Complex Single Engine and Light Twin Engine Airplanes (AC 61-9). In particular, observe carefully the warnings in the Practical Test Standards.

### ***SPINS***

A major cause of fatal accidents in general aviation airplanes is a spin. Stall demonstrations and practice are a means for a pilot to acquire the skills to recognize when a stall is about to occur and to recover as soon as the first signs of a stall are evident.

**If a stall does not occur - A spin cannot occur.**

It is important to remember, however, that a stall can occur in any flight attitude, at any airspeed, if controls are misused.

Unless your airplane has been specifically certificated in the aerobatic category and specifically tested for spin recovery characteristics, it is placarded against intentional spins.

The pilot of an airplane placarded against intentional spins should assume that the airplane may become uncontrollable in a spin, since its performance characteristics beyond certain limits specified in the FAA regulations may not have been tested and are unknown. This is why airplanes are placarded against intentional spins, and this is why stall avoidance is your protection against an inadvertent spin.

Pilots are taught that intentional spins are entered by deliberately inducing a yawing moment with the controls as the airplane is stalled. Inadvertent spins result from the same combination - stall plus yaw. That is why it is important to use coordinated controls and to recover at the first indication of a stall when practicing stalls.

Always remember that extra alertness and pilot techniques are required for slow flight maneuvers, including the practice or demonstration of stalls. In addition to the foregoing mandatory procedure, always:

- Be certain that the center of gravity of the airplane is as far forward as possible. Forward C.G. aids stall recovery, spin avoidance and spin recovery. An aft C.G. can create a tendency for a spin to stabilize, which delays recovery.
- Whenever a student pilot will be required to practice slow flight, be certain that the qualified instructor pilot has a full set of operable controls available. FAA regulations prohibit flight instruction without full dual controls.

- Conduct any maneuvers which could possibly result in a spin at altitudes in excess of five thousand (5,000) feet above ground level in clear air only.
- Remember that an airplane, at or near traffic pattern and approach altitudes, cannot recover from a spin, or perhaps even a stall, before impact with the ground. On final approach maintain at least the airspeed shown in the flight manual.
- Remember that if an airplane flown under instrument conditions is permitted to stall or enter a spin, the pilot, without reference to the horizon, is certain to become disoriented. He may be unable to recognize a stall, spin entry, or the spin condition and he may be unable to determine even the direction of the rotation.
- Finally, never forget that stall avoidance is your best protection against an inadvertent spin. **MAINTAIN YOUR AIRSPEED.**

In airplanes not certificated for aerobatics, spins are prohibited. If a spin is entered inadvertently:

Immediately move the control column full forward and simultaneously apply full rudder opposite to the direction of the spin; continue to hold this position until rotation stops and then neutralize all controls and execute a smooth pullout. Ailerons should be neutral and the throttle in idle position at all times during recovery.

### ***DESCENT***

In single engine piston-powered airplanes, supercharged or normally aspirated, it is necessary to avoid prolonged descents with low power, as this produces two problems: (1) excessively cool cylinder head temperatures which cause premature engine wear, and (2) excessively rich mixtures due to idle enrichment (and altitude) which causes soot and lead deposits on the spark plugs (fouling). The second of these is the more serious consideration; the engine may not

respond to the throttle when it is desired to discontinue the descent. Both problems are amenable to one solution: maintain adequate power to keep cylinder head temperature in the "green" range during descent, and lean to best power mixture (that is, progressively enrich the mixture from cruise only slightly as altitude decreases). This procedure will lengthen the descent, of course, and requires some advance planning. If it is necessary to make a prolonged descent at or near idle, as in practicing forced landings, at least avoid the problem of fouled spark plugs by frequently advancing the throttle until the engine runs smoothly, and maintain an appropriate mixture setting with altitude. (Refer to pre-landing check list.)

### ***VORTICES - WAKE TURBULENCE***

Every airplane generates wakes of turbulence while in flight. Part of this is from the propeller or jet engine, and part from the wing tip vortices. The larger and heavier the airplane, the more pronounced and turbulent the wakes will be. Wing tip vortices from large, heavy airplanes are very severe at close range, degenerating with time, wind and distance. These are rolling in nature, from each wing tip. In tests, vortex velocities of 133 knots have been recorded. Encountering the rolling effect of wing tip vortices within two minutes after passage of large airplanes is most hazardous to light airplanes. This roll effect can exceed the maximum counter-roll obtainable in a light airplane. The turbulent areas may remain for as long as three minutes or more, depending on wind conditions, and may extend several miles behind the airplane. Plan to fly slightly above and to the windward side of other airplanes. Because of the wide variety of conditions that can be encountered, there is no set rule to follow to avoid wake turbulence in all situations. However, the Airman's Information Manual, and to a greater extent Advisory Circular 90-23, Aircraft Wake Turbulence, provide a thorough discussion of the factors you should be aware of when wake turbulence may be encountered.

### ***TAKEOFF AND LANDING CONDITIONS***

When taking off on runways covered with water or freezing slush, the landing gear should remain extended for approximately ten seconds longer than normal, allowing the wheels to spin and dissipate the freezing moisture. The landing gear should then be cycled up, then down, wait approximately five seconds and then retracted again. Caution must be exercised to insure that the entire operation is performed below Maximum Landing Gear Operating Airspeed.

Use caution when landing on runways that are covered by water or slush which cause hydroplaning (aquaplaning), a phenomenon that renders braking and steering ineffective because of the lack of sufficient surface friction. Snow and ice covered runways are also hazardous. The pilot should also be alert to the possibility of the brakes freezing.

Use caution when taking off or landing during gusty wind conditions. Also be aware of the special wind conditions caused by buildings or other obstructions located near the runway.

### **MEDICAL FACTS FOR PILOTS**

#### ***GENERAL***

When the pilot enters the airplane, he becomes an integral part of the man-machine system. He is just as essential to a successful flight as the control surfaces. To ignore the pilot in preflight planning would be as senseless as failing to inspect the integrity of the control surfaces or any other vital part of the machine. The pilot has the responsibility for determining his reliability prior to entering the airplane for flight. When piloting an airplane, an individual should be free of conditions which are harmful to alertness, ability to make correct decisions, and rapid reaction time.

## ***FATIGUE***

Fatigue generally slows reaction time and causes errors due to inattention. In addition to the most common cause of fatigue; insufficient rest and loss of sleep, the pressures of business, financial worries, and family problems can be important contributing factors. If you are tired, don't fly.

## ***HYPOXIA***

Hypoxia, in simple terms, is a lack of sufficient oxygen to keep the brain and other body tissues functioning properly. There is a wide individual variation in susceptibility to hypoxia. In addition to progressively insufficient oxygen at higher altitudes, anything interfering with the blood's ability to carry oxygen can contribute to hypoxia (anemias, carbon monoxide, and certain drugs). Also, alcohol and various drugs decrease the brain's tolerance to hypoxia.

Your body has no built-in alarm system to let you know when you are not getting enough oxygen. It is impossible to predict when or where hypoxia will occur during a given flight, or how it will manifest itself. Some of the common symptoms of hypoxia are increased breathing rate, a light-headed or dizzy sensation, tingling or warm sensation, sweating, reduced visual field, sleepiness, blue coloring of skin, fingernails, and lips, and behavior changes. A particularly dangerous feature of hypoxia is an increased sense of well-being, called euphoria. It obscures a person's ability and desire to be critical of himself, slows reaction time, and impairs thinking ability. Consequently, a hypoxic individual commonly believes things are getting progressively better while he nears total collapse.

The symptoms are slow but progressive, insidious in onset, and are most marked at altitudes starting above ten thousand feet. Night vision, however, can be impaired starting at an altitude of 5,000 feet. Persons who have recently indulged in alcohol, who are moderate to heavy smokers, or

who take certain drugs, may be more susceptible to hypoxia. Susceptibility may also vary in the same individual from day to day or even morning to evening. Use oxygen on flights above 10,000 feet and at any time when symptoms appear.

Depending upon altitude, a hypoxic individual has a limited time to make decisions and perform useful acts, even though he may remain conscious for a longer period. The time of useful consciousness is approximately 3-5 minutes at 25,000 feet of altitude and diminishes markedly as altitude increases.

Should symptoms occur that cannot definitely be identified as either hypoxia or hyperventilation, try three or four deep breaths of oxygen. The symptoms should improve markedly if the condition was hypoxia (recovery from hypoxia is rapid).

Pilots who fly to altitudes that require or may require the use of supplemental oxygen should be thoroughly familiar with the operation of the airplane oxygen systems. A preflight inspection of the system should be performed, including proper fit of the mask. The passengers should be briefed on the proper use of their oxygen system before flight.

Pilots who wear beards should be careful to ensure that their beard is carefully trimmed so that it will not interfere with proper sealing of the oxygen masks. If you wear a beard or moustache, test the fit of your oxygen mask on the ground for proper sealing. Studies conducted by the military and oxygen equipment manufacturers conclude that oxygen masks do not seal over beards or heavy facial hair.

Federal Aviation Regulations related to the use of supplemental oxygen by flight crew and passengers must be adhered to if flight at higher altitudes is to be accomplished safely. Passengers with significant circulatory or lung disease may need to use supplemental oxygen at lower altitudes than specified by these regulations.

## ***HYPERVENTILATION***

Hyperventilation, or overbreathing, is a disturbance of respiration that may occur in individuals as a result of emotional tension or anxiety. Under conditions of emotional stress, fright, or pain, breathing rate may increase, causing increased lung ventilation, although the carbon dioxide output of the body cells does not increase. As a result, carbon dioxide is "washed out" of the blood. The most common symptoms of hyperventilation are: dizziness, nausea, sleepiness, and finally, unconsciousness. If the symptoms persist, discontinue use of oxygen and consciously slow your breathing rate until symptoms clear, and then resume normal breathing rate. Normal breathing can be aided by talking aloud.

## ***ALCOHOL***

Common sense and scientific evidence dictate that you must not fly as a crew member while under the influence of alcohol. Alcohol, even in small amounts, produces (among other things):

- A dulling of critical judgement.
- A decreased sense of responsibility.
- Diminished skill reactions and coordination.
- Decreased speed and strength of muscular reflexes (even after one ounce of alcohol).
- Decreases in efficiency of eye movements during reading (after one ounce of alcohol).
- Increased frequency of errors (after one ounce of alcohol).
- Constriction of visual fields.
- Decreased ability to see under dim illuminations.
- Loss of efficiency of sense of touch.
- Decrease of memory and reasoning ability.

- Increased susceptibility to fatigue and decreased attention span.
- Decreased relevance of response.
- Increased self confidence with decreased insight into immediate capabilities.

Tests have shown that pilots commit major errors of judgment and procedure at blood alcohol levels substantially less than the minimum legal levels of intoxication for most states. These tests further show a continuation of impairment from alcohol up to as many as 14 hours after consumption, with no appreciable diminution of impairment. The body metabolizes ingested alcohol at a rate of about one-third of an ounce per hour. Even after the body completely destroys a moderate amount of alcohol, a pilot can still be severely impaired for many hours by hangover. The effects of alcohol on the body are magnified at altitudes, as 2 oz. of alcohol at 18,000 feet produce the same adverse effects as 6 oz. at sea level.

Federal Aviation Regulations have been amended to reflect the FAA's growing concern with the effects of alcohol impairment. FAR 91 states:

**"Alcohol or drugs.**

(a) No person may act or attempt to act as a crew-member of a civil aircraft -

- (1) Within 8 hours after the consumption of any alcoholic beverage;
- (2) While under the influence of alcohol;
- (3) While using any drug that affects the person's faculties in any way contrary to safety; or
- (4) While having .04 percent by weight or more alcohol in the blood.

(b) Except in an emergency, no pilot of a civil aircraft may allow a person who appears to be intoxicated or who demonstrates by manner or physical indications that the individual is under the influence of drugs (except a medical patient under proper care) to be carried in that aircraft."

Because of the slow destruction of alcohol by the body, a pilot may still be under influence eight hours after drinking a moderate amount of alcohol. Therefore, an excellent rule is to allow at least 12 to 24 hours between "bottle and throttle," depending on the amount of alcoholic beverage consumed.

### ***DRUGS***

Self-medication or taking medicine in any form when you are flying can be extremely hazardous. Even simple home or over-the-counter remedies and drugs such as aspirin, anti-histamines, cold tablets, cough mixtures, laxatives, tranquilizers, and appetite suppressors, may seriously impair the judgment and coordination needed while flying. The safest rule is to take no medicine before or while flying, except after consultation with your Aviation Medical Examiner.

### ***SCUBA DIVING***

Flying shortly after any prolonged scuba diving could be dangerous. Under the increased pressure of the water, excess nitrogen is absorbed into your system. If sufficient time has not elapsed prior to takeoff for your system to rid itself of this excess gas, you may experience the bends at altitudes even under 10,000 feet, where most light planes fly.

### ***CARBON MONOXIDE AND NIGHT VISION***

The presence of carbon monoxide results in hypoxia which will affect night vision in the same manner and extent as hypoxia from high altitudes. Even small levels of carbon

monoxide have the same effect as an altitude increase of 8,000 to 10,000 feet. Smoking several cigarettes can result in a carbon monoxide saturation sufficient to affect visual sensitivity equal to an increase of 8,000 feet altitude.

### ***DECOMPRESSION SICKNESS***

Pilots flying unpressurized airplanes at altitudes in excess of 10,000 feet should be alert for the symptoms of 'decompression sickness'. This phenomenon, while rare, can impair the pilot's ability to perform and in extreme cases, can result in the victim being rendered unconscious. Decompression sickness, also known as dysbarism and aviators "bends", is caused by nitrogen bubble formation in body tissue as the ambient air pressure is reduced by climbing to higher altitudes. The symptoms are pain in the joints, abdominal cramps, burning sensations in the skin, visual impairment and numbness. Some of these symptoms are similar to hypoxia. The only known remedy for decompression sickness is recompression, which can only be accomplished in an unpressurized airplane by descending. The pilot should immediately descend if it is suspected that this condition exists, since the effects will only worsen with continued exposure to the reduced pressure environment at altitude and could result, if uncorrected, in complete incapacitation. The possibility of decompression sickness can be greatly reduced by pre-breathing oxygen prior to flight and by commencing oxygen breathing well below the altitudes where it is legally mandatory.

## **A FINAL WORD**

Airplanes are truly remarkable machines. They enable us to shrink distance and time, and to expand our business and personal horizons in ways that, not too many years ago, were virtually inconceivable. For many businesses, the general aviation airplane has become the indispensable tool of efficiency.

Advances in the mechanical reliability of the airplanes we fly have been equally impressive, as attested by the steadily declining statistics of accidents attributed to mechanical causes, at a time when the airframe, systems and power plants have grown infinitely more complex. The explosion in capability of avionics systems is even more remarkable. Radar, RNAV, LORAN, sophisticated autopilots and other devices which, just a few years ago, were too large and prohibitively expensive for general aviation size airplanes, are becoming increasingly commonplace in even the smallest airplanes.

It is thus that this Safety Information is directed to the pilot, for it is in the area of the skill and proficiency of you, the pilot, that the greatest gains in safe flying are to be made over the years to come. Intimate knowledge of your airplane, its capabilities and its limitations, and disciplined adherence to the procedures for your airplane's operation, will enable you to transform potential tragedy into an interesting hangar story when - as it inevitably will - the abnormal situation is presented.

Know your airplane's limitations, and your own. Never exceed either.

Safe flying,

**BEECH AIRCRAFT CORPORATION**

***THIS PAGE INTENTIONALLY LEFT BLANK***